

# Installation Manual of SPT

Doc. NO. : SPT\_INS\_EN

Version: A00

---

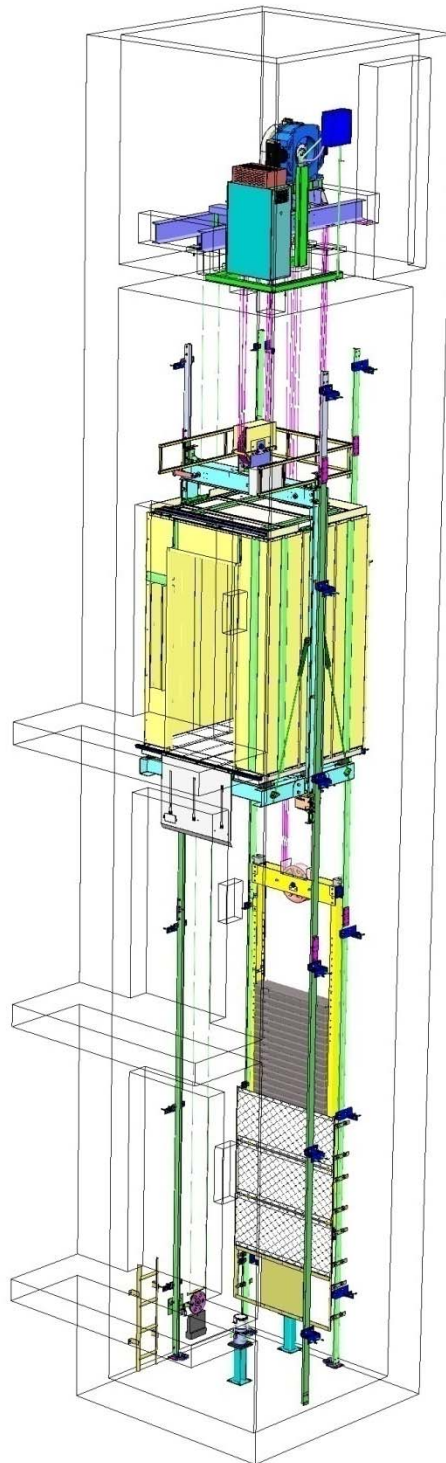

## Installation Manual of SPT

---

---

## Table of Contents

1	Safety rules.....	5
2	Storage and transport .....	6
2.1	Storage .....	6
2.2	Transport .....	6
3	Preparation before installation .....	7
3.1	Set up scaffold .....	8
3.2	Protection for the holes in machine room .....	12
3.3	Installation of landing door protection handrail .....	13
3.4	Set up sample framework .....	14
4	Installation of guide rail .....	16
4.1	Guide rail transport and storage .....	17
4.2	Installation of rail bracket.....	18
4.3	Installation of rail seat.....	21
4.4	Installation of guide rail.....	22
4.5	Correction of guide rail.....	24
4.6	Installation of oil catcher.....	27
5	Installation of landing door .....	28
5.1	Installation of landing door sill.....	30
5.2	Installation of landing door jamb .....	37
5.3	Installation of landing door header.....	43
5.4	Installation of landing door panel .....	49
5.5	Installation of door close weight.....	55
5.6	Adjust landing door lock.....	58
6	Installation of machine.....	59
6.1	Pre-installation preparations.....	61
6.2	Installation of machine beam.....	62
6.3	Installation of machine.....	64
7	Installation of counterweight .....	74
7.1	Installation of counterweight frame.....	75
7.2	Installation of counterweight accessories.....	76
7.3	Installation of counterweight screen.....	79
8	Installation of car frame .....	81
8.1	Installation of safety gear .....	83
8.2	Installation of sub-frame .....	84
8.3	Installation of bottom guide.....	85
	The roller guide throat center match with guide rail center. ....	85
8.4	Installation of uprights .....	87
8.5	Installation of crosshead .....	89
8.6	Installation of top guide .....	91
8.7	Installation of safety linkage.....	92
8.8	Installation of top of car sheave .....	94

---

8.9	Installation of platform.....	96
8.10	Install the balance block.....	100
9	Installation of traction rope.....	101
10	Installation of hoistway mechanical components.....	105
10.1	Installation of pit ladder.....	106
10.2	Installation of speed governor.....	107
10.3	Installation of tension device.....	108
10.4	Installation of speed governor rope.....	110
10.5	Installation of buffer.....	111
11	Installation electrical components in machine room.....	114
11.1	Installation of controller.....	115
11.2	Installation of receiving box.....	116
11.3	Installation of machine room wiring.....	117
11.4	Install hand wheel.....	118
12	Installation of compensation chain.....	119
13	Installation of cab.....	122
13.1	Installation of car panel.....	123
13.2	Installation of car ceiling.....	125
13.3	Installation of TOC handrail.....	127
13.4	Installation of car fan.....	128
13.5	Installation of TOC junction box.....	129
13.6	Installation of toe guard.....	130
13.7	Installation of car floor.....	131
13.8	Installation of load weighing device.....	132
14	Installation of car door system.....	133
14.1	Installation of door operator.....	137
14.2	Installation of car door panel.....	141
14.3	Installation of door vane.....	153
14.4	Installation of door protection device.....	156
15	Installation of position reference system.....	158
15.1	Installation of limit switch.....	159
15.2	Installation of leveling device.....	161
16	Installation of wiring.....	162
16.1	Installation of travelling cable.....	162
16.2	Installation of hoistway wiring.....	166
16.3	Installation of hoistway light.....	167
16.4	Installation of pit wiring.....	168
16.5	Installation of car wiring.....	169
16.6	Installation of inter-communication device.....	170
17	Installation of human interface device.....	172
17.1	Installation of car operation panel.....	172
17.2	Installation of hall fixture.....	173
18	Installation finishing work.....	174

---

## SPT\_INS\_EN

---

18.1	Clean up .....	174
19	Annex.....	174
19.1	Fastener tightening torque requirements .....	174
19.2	Expansion bolt installation .....	174

## 1 Safety rules

All field staff is under an obligation to keep below rules:

- 1) Keep work place cleanly;
- 2) There shall have sufficient light at work place;
- 3) The safety device shall be maintained regularly or replaced if necessary;
- 4) The lifting equipment must be examined before put in to use;
- 5) Carry a heavy load we must maintain the correct posture in order to avoid bodily injury;
- 6) Make sure the machine room door locked;
- 7) All field staff must wear personal protective products: helmet, goggles, safety gloves, overalls, safety belt, safety shoes;

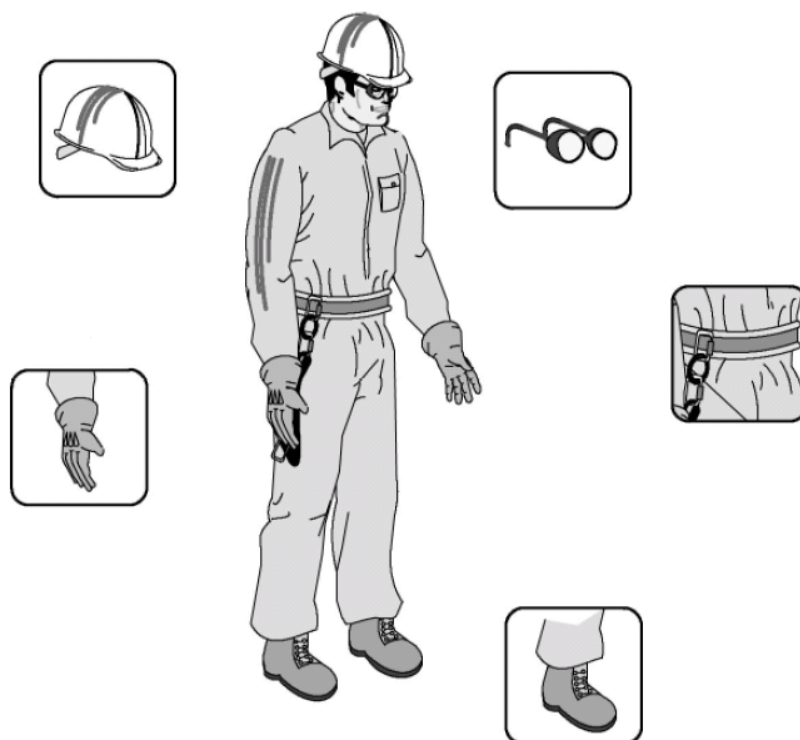

## **2 Storage and transport**

### **2.1 Storage**

The packing boxes must be stacked at cleanly, dry place and with awning at jobsite. Pay attention there is no combustibles around packing boxes, oxygen cutting or any other incensive job was interdicted.

All the packing boxes shall be stacked on thick plank, make sure the water on floor can't damp the boxes.

The packing boxes shall not stack at heavy traffic area. All the packing boxes shall be covered by canvas and fastened by rope to avoid blow away. Security is necessary to insure all the material not be stole or damaged.

The packing boxes shall not be stacked too high. The heavier boxes shall be stacked below the light boxes. Anything stack on guide rail is interdicted.

The packing boxes shall be ordered stacked according the installation process. The packing boxes for same elevator shall be stacked separated and do not fixed with other elevator.

***The elevator material stored at outside is not allowed anytime!***

### **2.2 Transport**

Please very carefully when transport elevator material at jobsite, make sure there is no damage on elevator material.

Use mechanical device to pull the elevator material is not allowed, especially guide rail. The appropriate device shall be used to transport cumbersome material.

Always comply with safety rules of lifting. The inexperience worker must be under guidance by specialize worker for the lifting work.

Only the lifting device with regular maintenance can be use for lifting.

### **3 Preparation before installation**

The preparation of Project engineers and project supervisors:

Before installation, project engineers or project supervisors will carefully check and measure the installation field according to the construction drawing, which includes the check or the measuring of the landing numbers, the height of the top floor, the depth of the pit, the height of the elevators (or lifts) as well as the dimension and verticality of the rail well. They will also check whether the preformed hole of the hall doorway, the embedded part of the rail well as well as the preformed hole site in the machine room and the like are in consistency with the drawings or not. Afterwards, they will make an attentive analysis and research on the construction field so as to ensure a smooth installation of the elevators (or lifts).

Project engineers and project supervisors should have the knowledge about the power supply in actual use, the power supply for temporary use during the installation and the illumination so that they are able to work out a plan about the layout of the electrical equipment, the power supply for temporary use as well as the field illumination and afterwards timely come into contact with party A for help.

In light of the actual situation, project engineers should work out an installation plan and work assignments for all the departments engaged in the construction work.

The preparation of installation workers:

The installation personnel should be equipped with the basic knowledge about the type, specification as well as the properties of elevators (or lifts) and should also be familiar with installation diagrams, electrical diagrams and wire diagrams.

---

### 3.1 Set up scaffold

Scaffold overview:

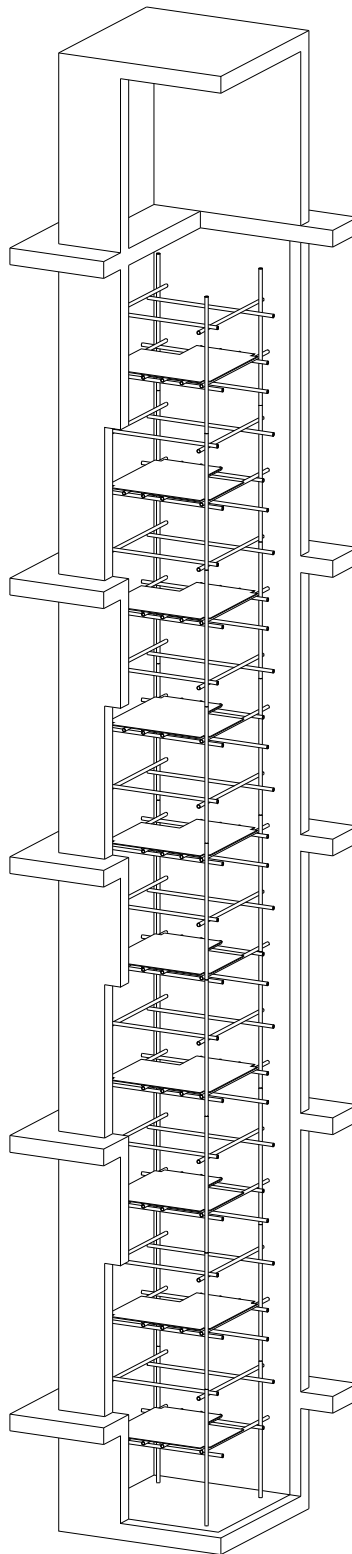



Step	Instruction	Fig
1	Define the scaffold position in hoistway.	Figure 3-1 Figure 3-2
2	Install scaffold from bottom to top.	Figure 3-3
3	Detailed description of working platform.	Figure 3-4

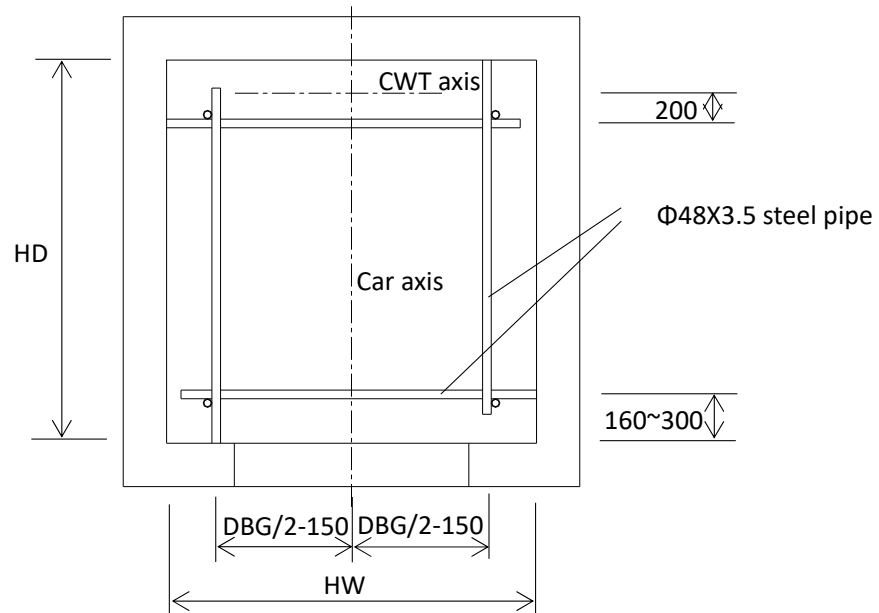

Figure 3-1 (Rear Counterweight)

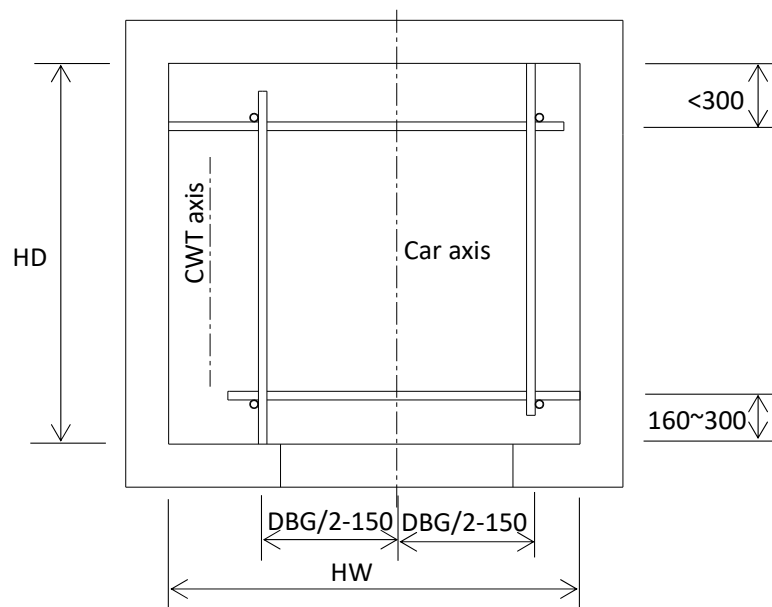

Figure 3-2 (Side Counterweight)

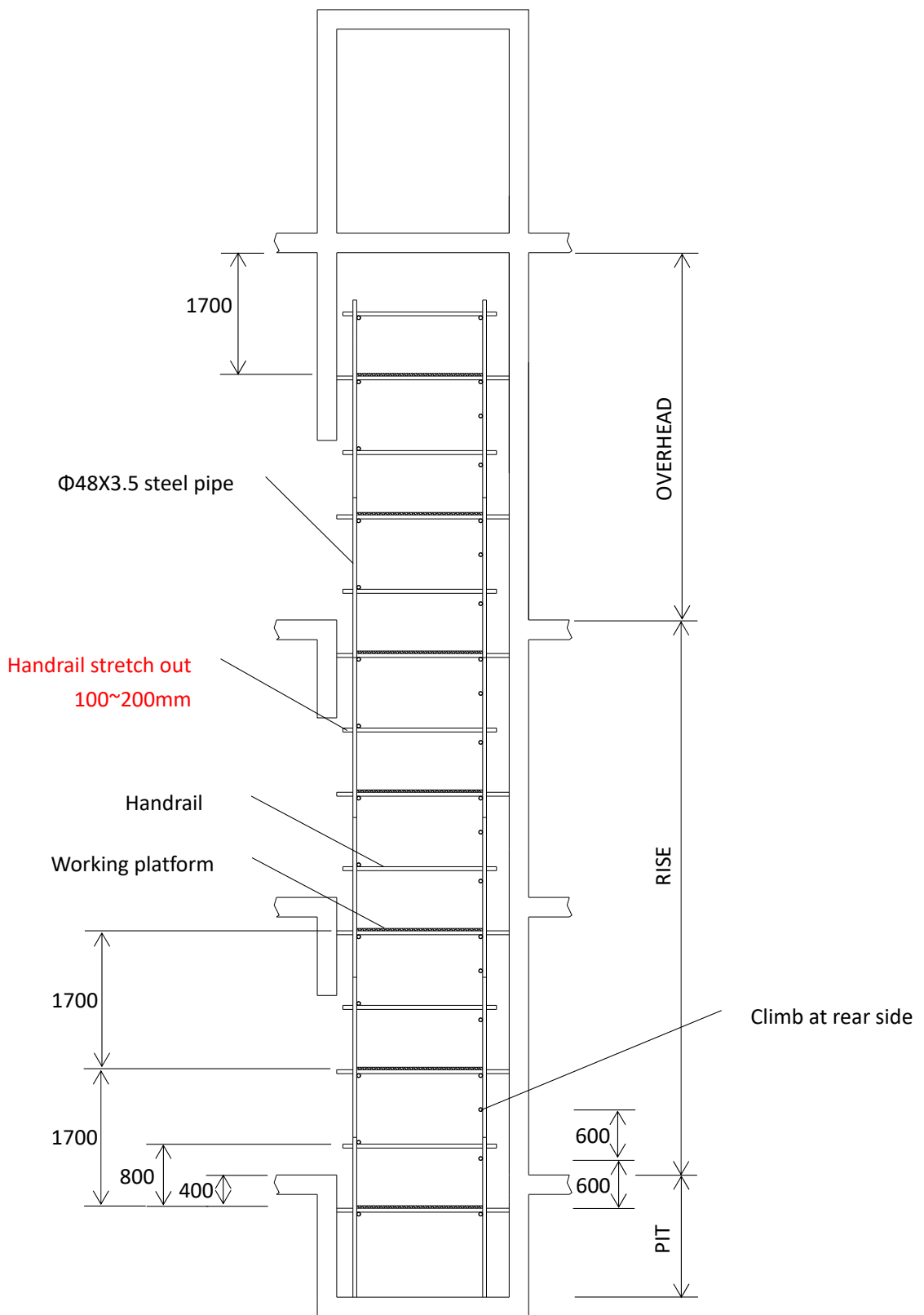

Figure 3-3

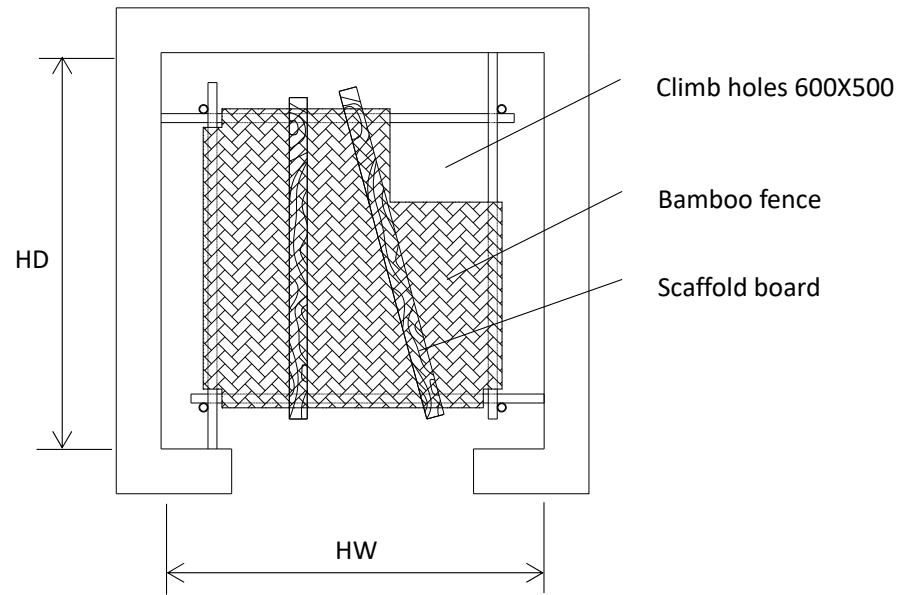

Figure 3-4

**Caution: Scaffold strength  $\geq 2500\text{N/m}^2$ !**

### 3.2 Protection for the holes in machine room

Step	Instruction	Fig
1	Build terraces around the holes in the machine room.	Figure 3-5
2	Cover the holes.	Figure 3-6

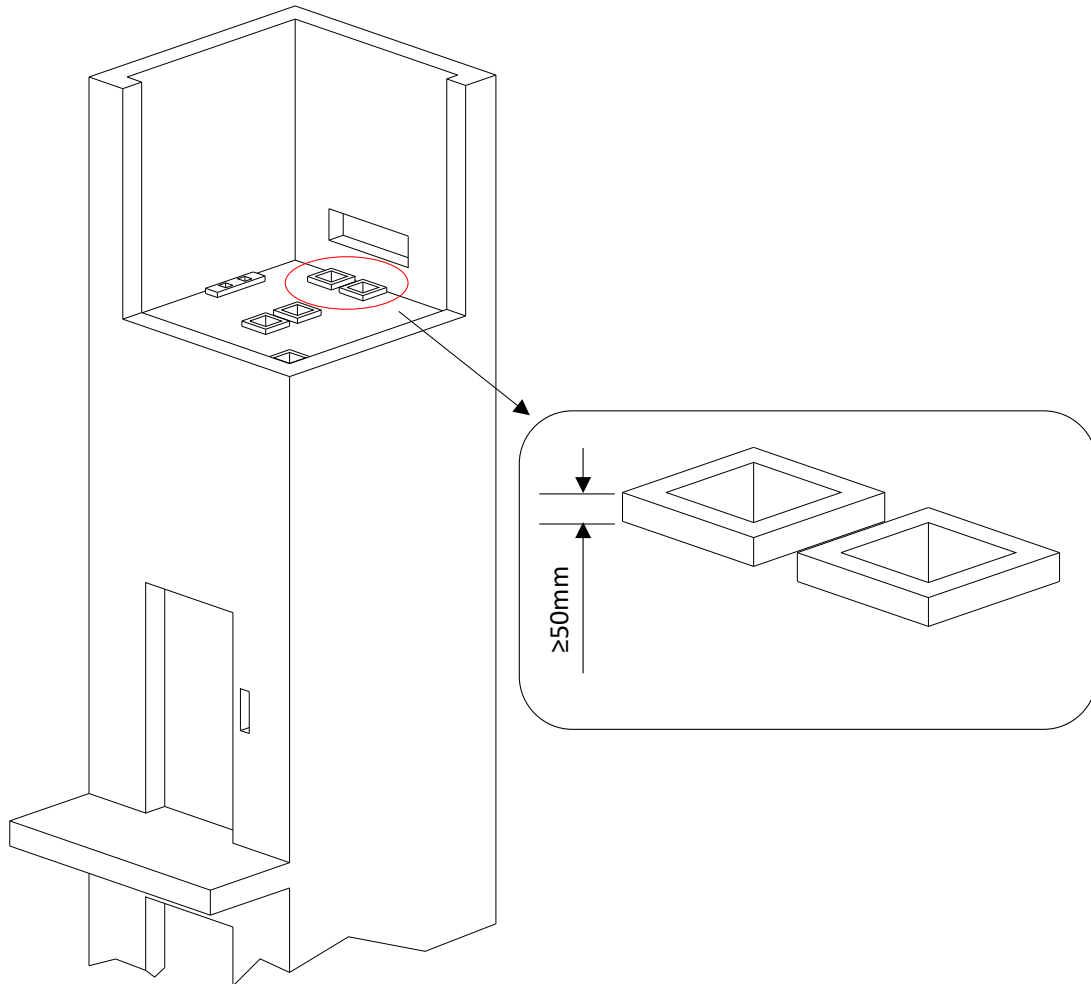

Figure 3-5

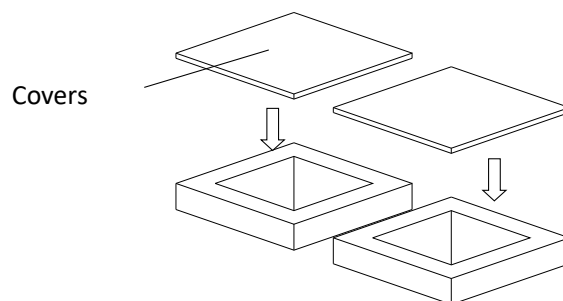

Figure 3-6

### 3.3 Installation of landing door protection handrail

Step	Instruction	Fig
1	Install landing door protective devices at each floor.	Figure 3-7

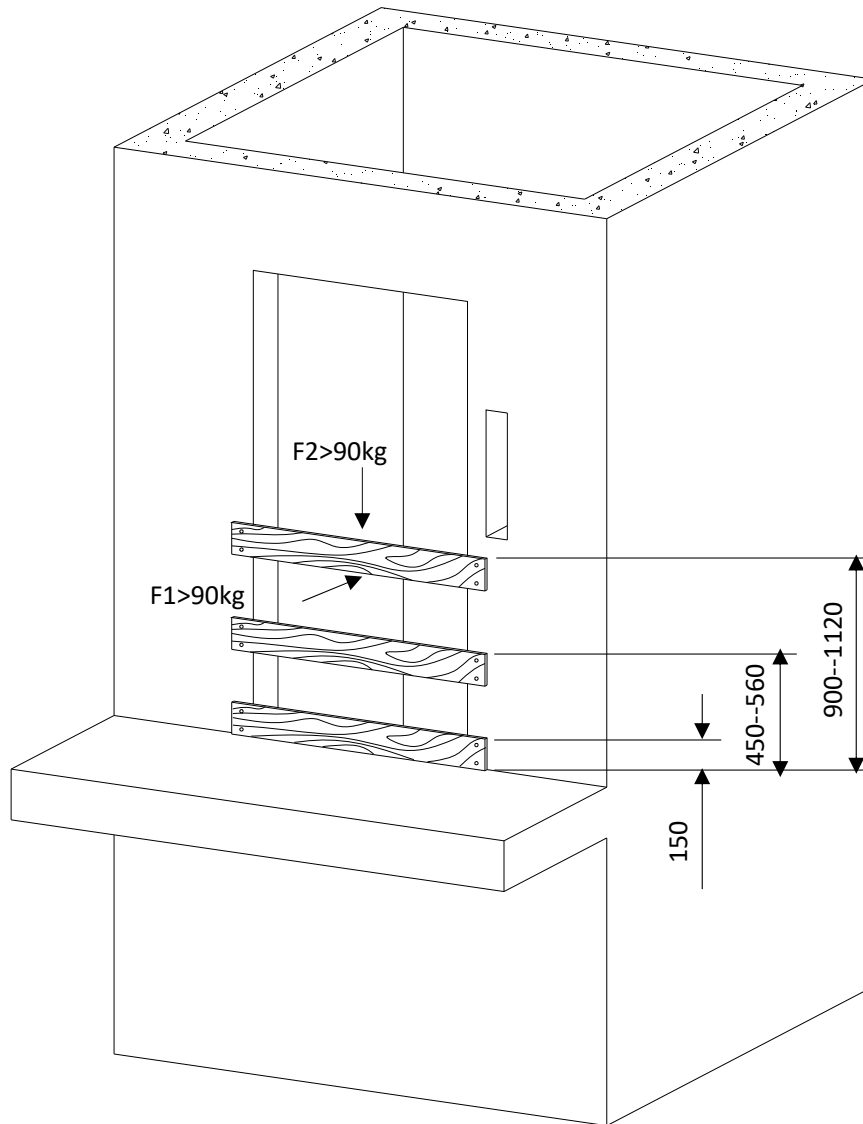

Figure 3-7

### 3.4 Set up sample framework

Step	Instruction	Fig
1	Find out the position of 6 plumb lines.	Figure 3-8
2	Build upper sample plate and lower sample plate.	Figure 3-9

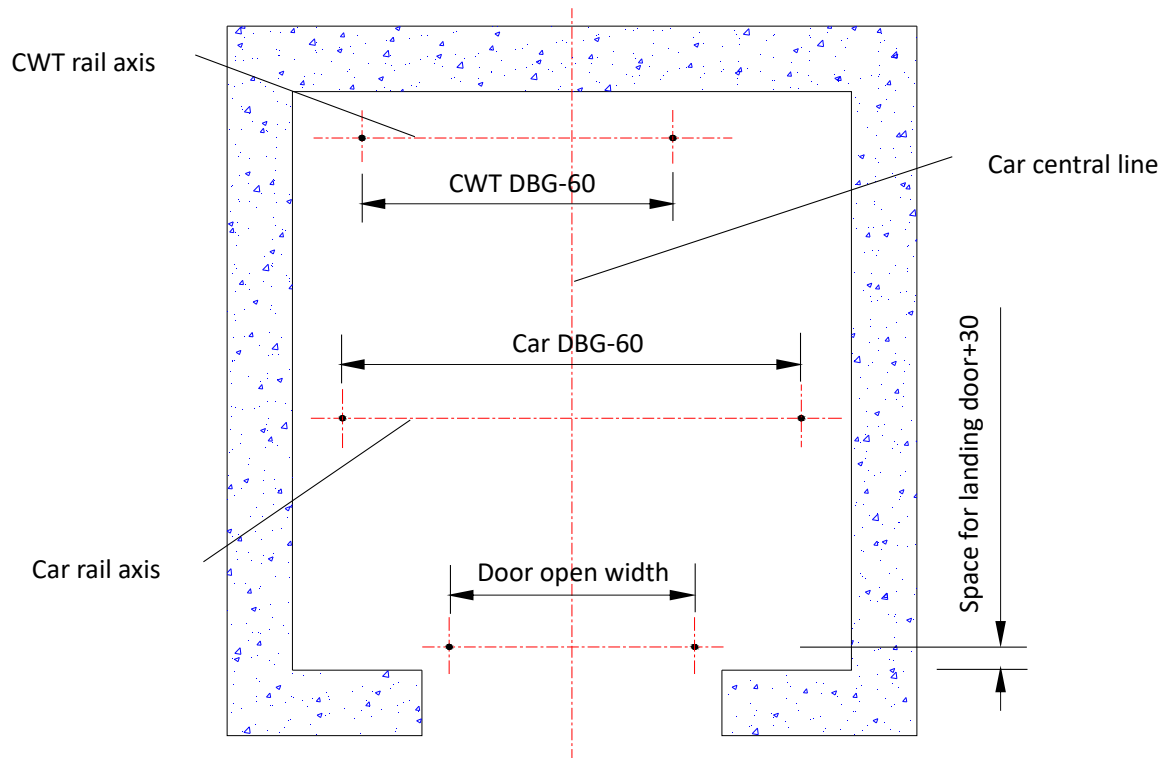

Figure 3-8

*The deviation of baseline should not exceed 0.3mm*

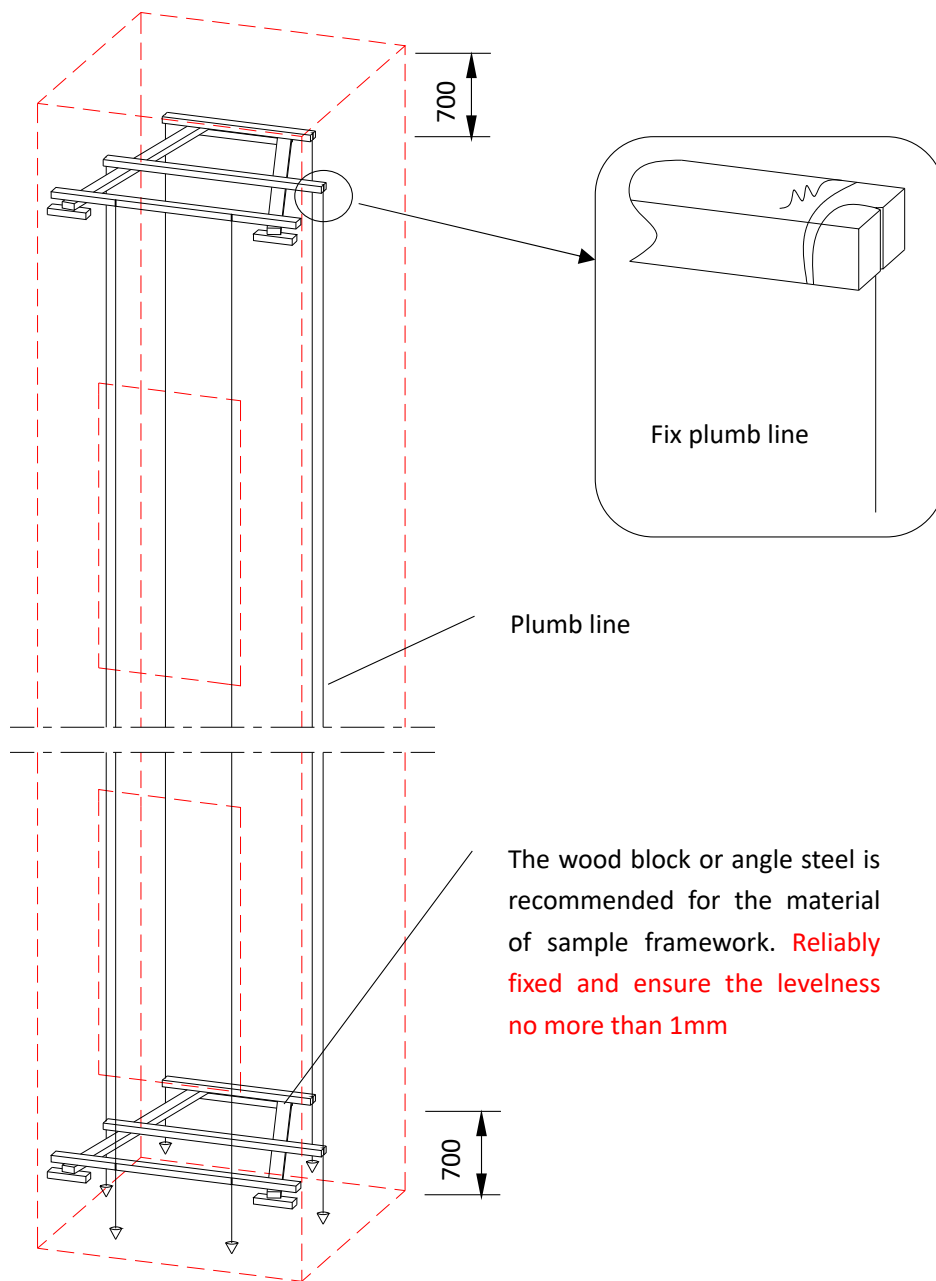
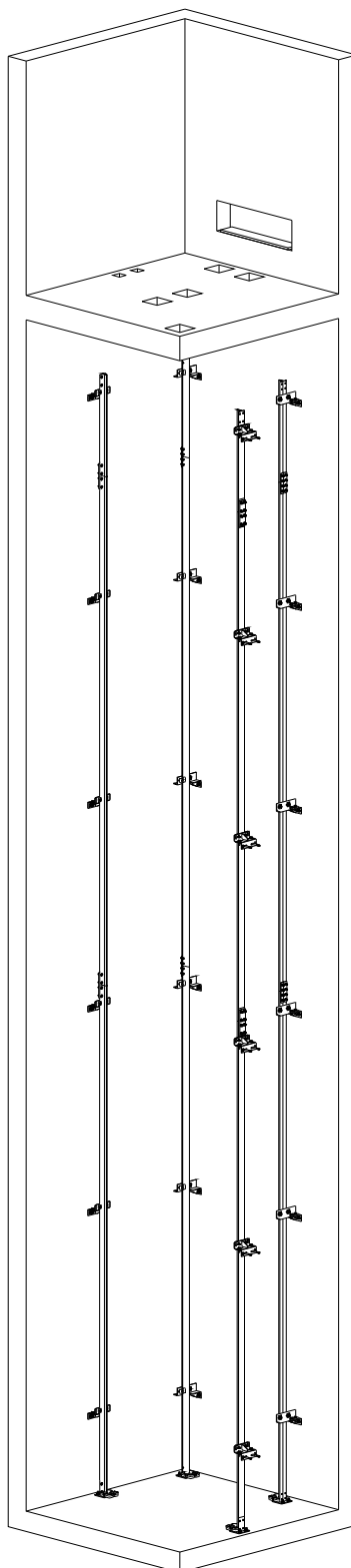

Figure 3-9

Notes: here gives one type of sample frameworks. Other appropriate method of sample frameworks can be used.

## 4 Installation of guide rail

Guide rail installation overview:





---

## 4.1 Guide rail transport and storage

### 4.1.1 Transport

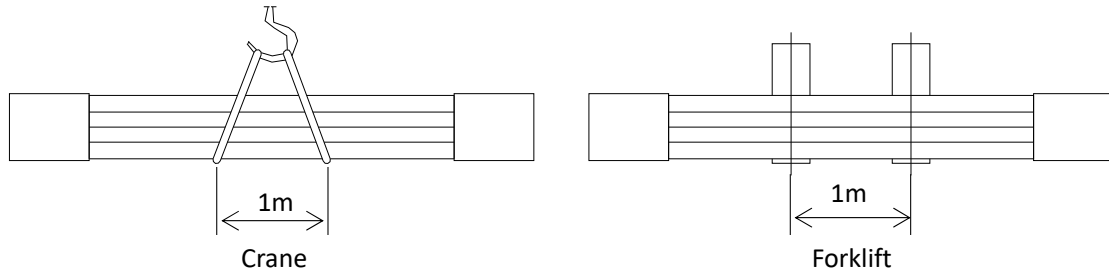

Figure 4-1

### 4.1.2 Storage

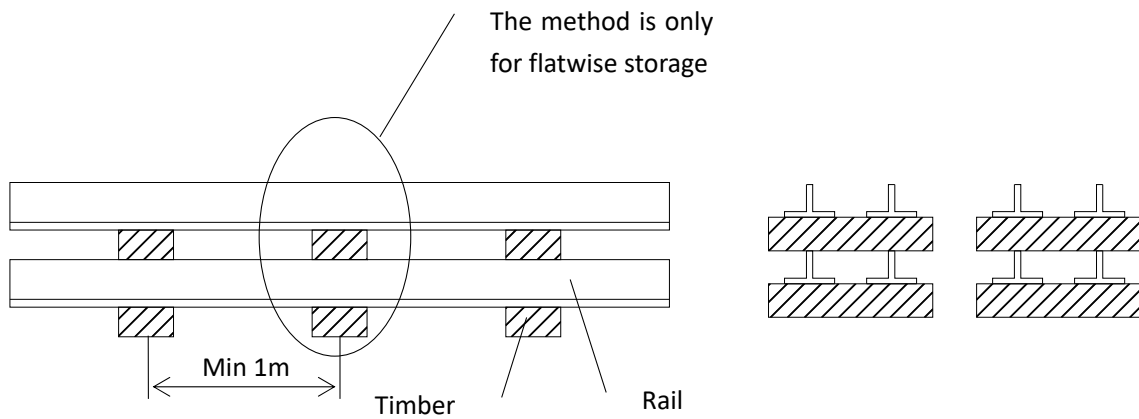

Figure 4-2

## 4.2 Installation of rail bracket

### 4.2.1 Installation car rail bracket

Step	Instruction	Fig
1	The position of rail bracket in hoistway.	Figure 4-3
2	Connect the fixed support on the well wall.	Figure 4-4
3	Connect the rail support on fixed support.	Figure 4-5

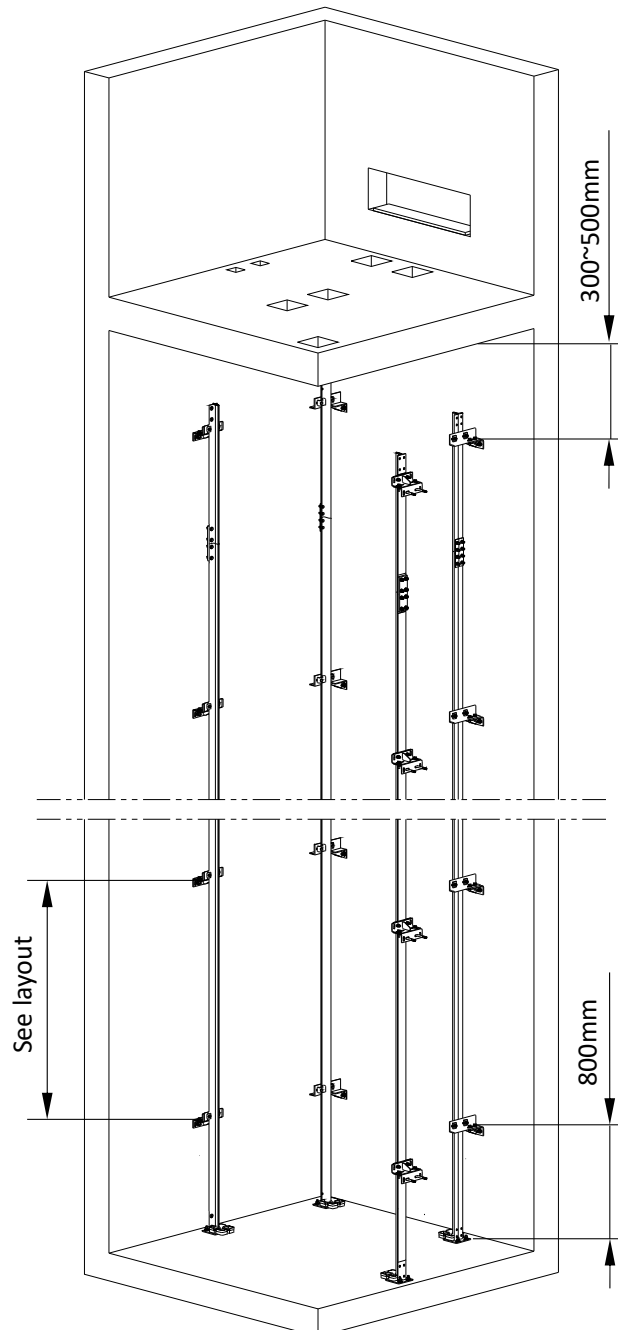

Figure 4-3

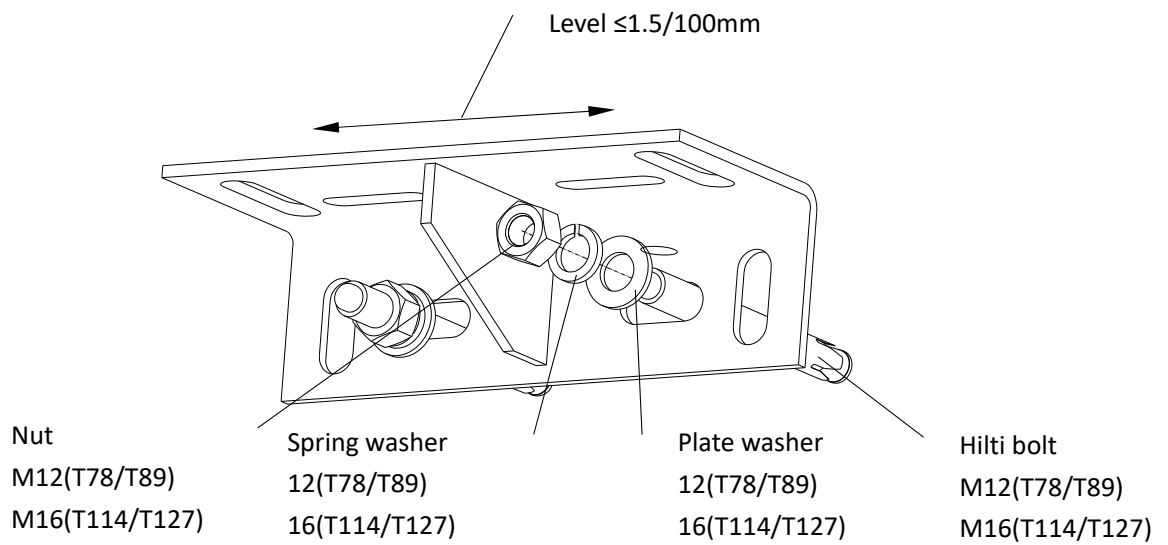

Figure 4-4

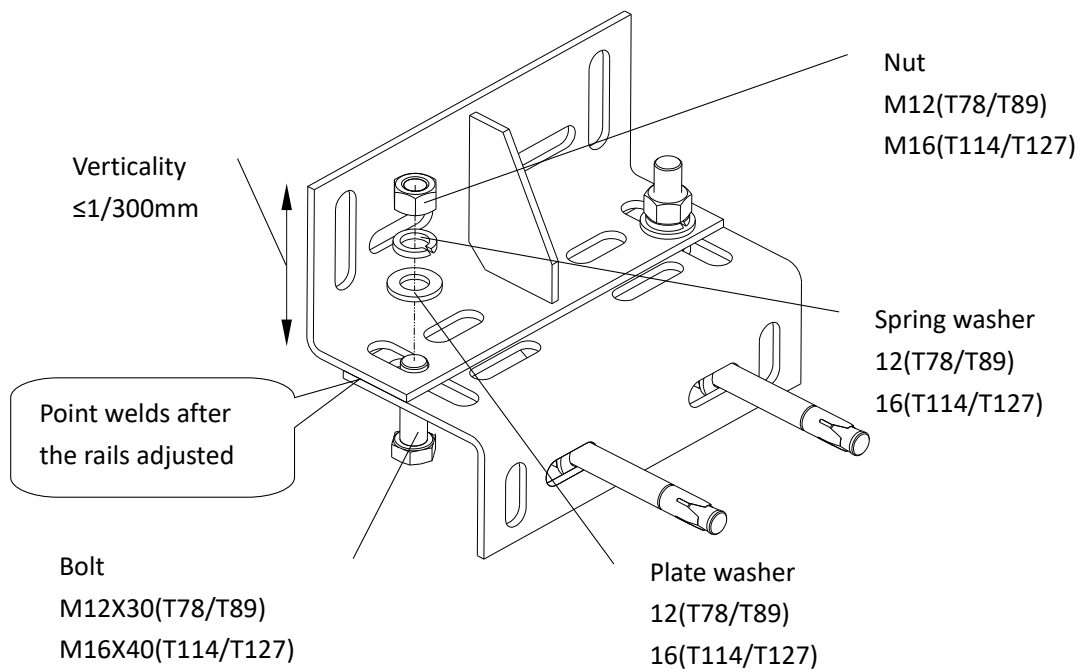

Figure 4-5

### 4.2.2 Installation counterweight rail bracket

Step	Instruction	Fig
1	Connect the fixed support on the well wall.	Figure 4-6
2	Connect the rail support on fixed support.	Figure 4-7

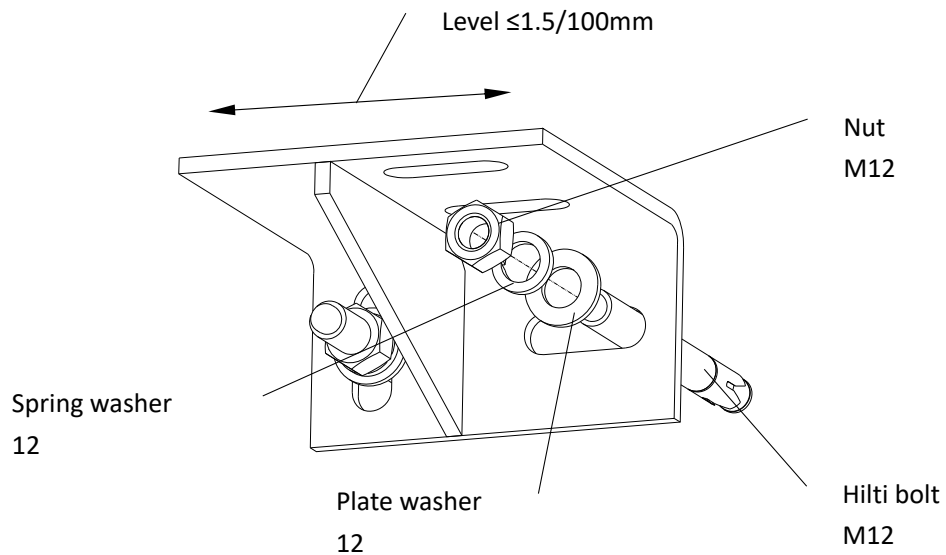

Figure 4-6

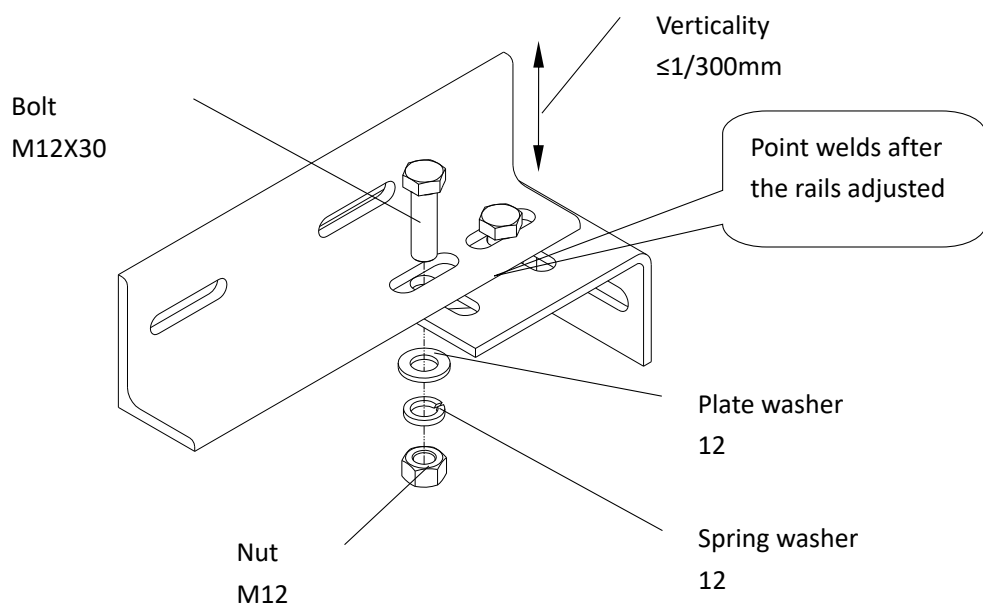

Figure 4-7

**Note:**

The distance between rail bracket and fishplate shall more than 300mm.

---

**4.3 Installation of rail seat**

Step	Instruction	Fig
1	Connect the rail seat on the pit floor.	Figure 4-8

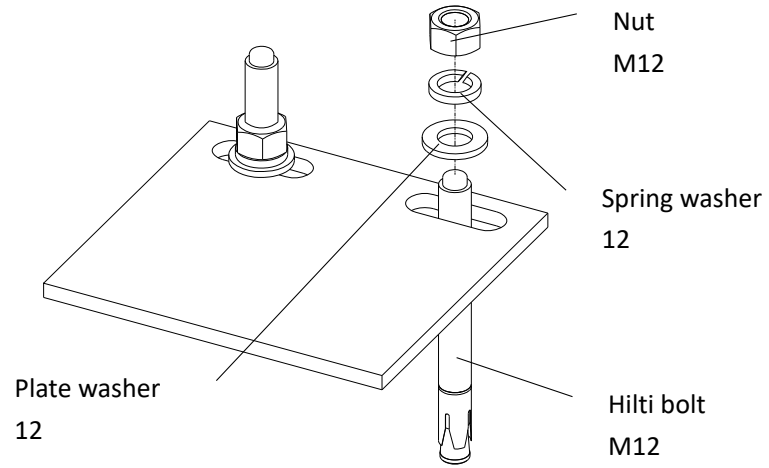

Figure 4-8

## 4.4 Installation of guide rail

### 4.4.1 Installation of car guide rail

Step	Instruction	Fig
1	Connect the rails on the rail brackets by clips.	Figure 4-9
2	Connected the rail to the rail by fishplate.	Figure 4-10

***In order to guarantee the quality of the connection point, the machining end faces and fishplates must be thoroughly clean.***

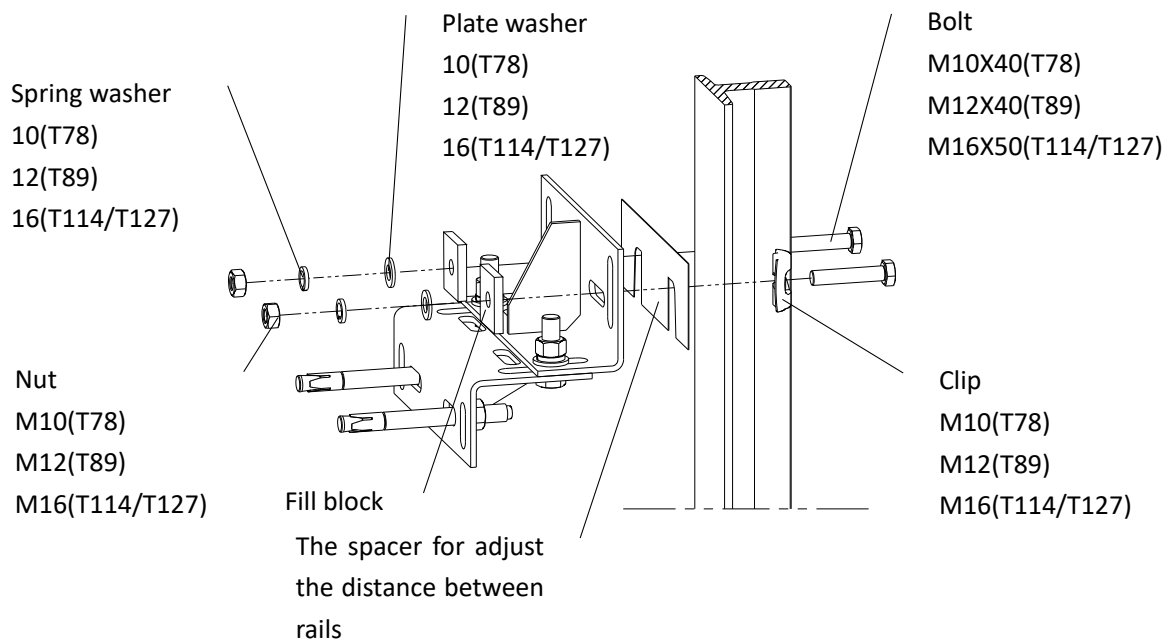

Figure 4-9

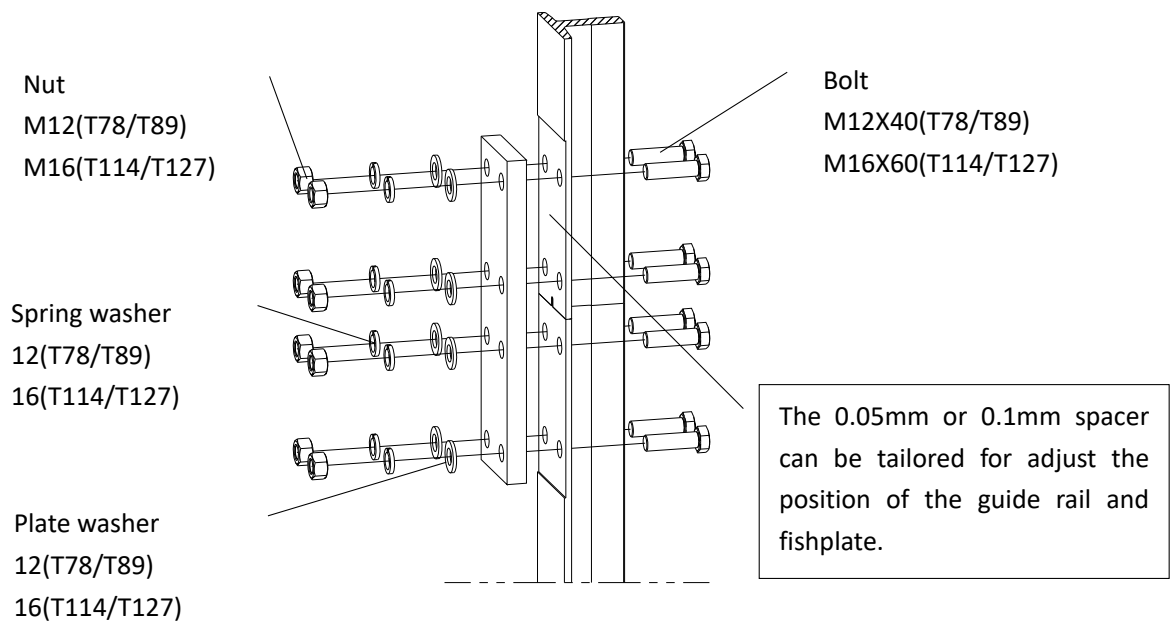

Figure 4-10

### 4.4.2 Installation of counterweight guide rail

Step	Instruction	Fig
1	Connect the rails on the rail brackets by clips.	Figure 4-11
2	Connected the rail to the rail by fishplate.	Figure 4-12

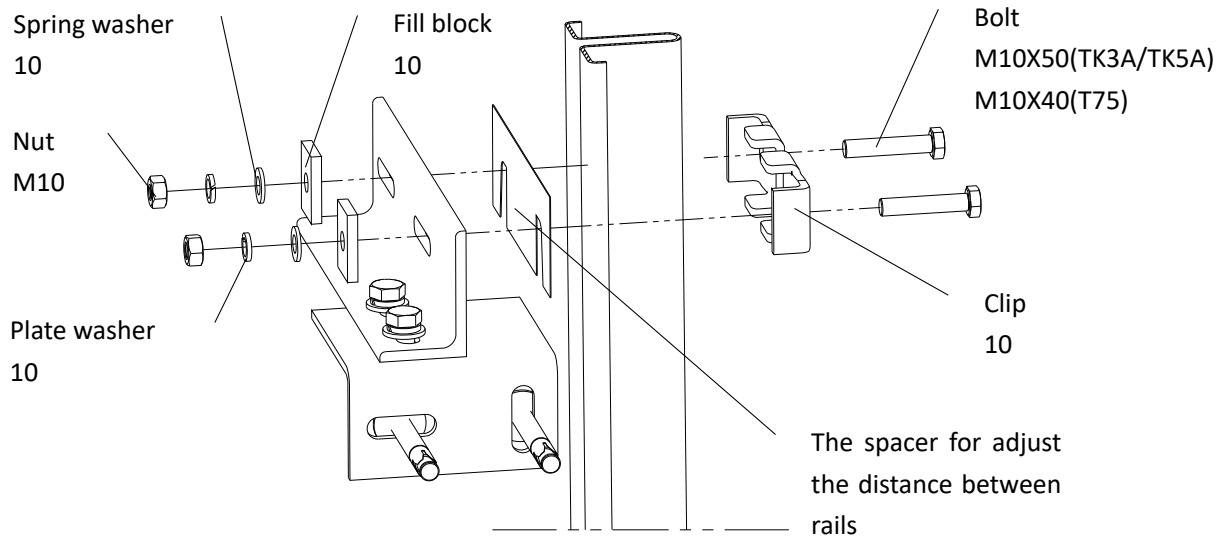

Figure 4-11

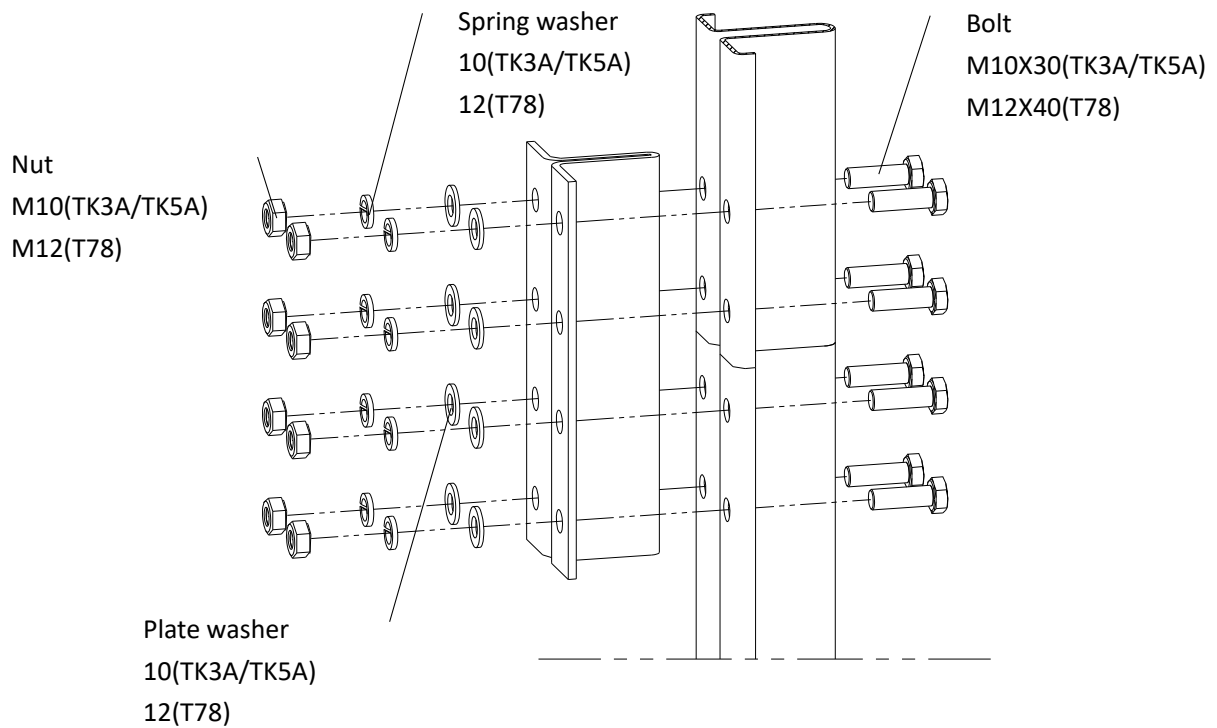

Figure 4-12

## 4.5 Correction of guide rail

Step	Instruction	Fig
1	Measure distance between the plumb line and the top surface of guide rails with a steel ruler and estimate whether the distance is of too much deviation from 30mm or not. If this is the case, add or remove some shims, or adjust rail brackets when necessary.	Figure 4-13
2	Measure plumb between the plumb line and the surface of guide rails with guide rail calipers. Calibrate guide rails with a hammer when the deviation is too large.	Figure 4-14
3	The deviation for guide relative to standard baseline.	Figure 4-15
4	Calibrate distortion of guide rail sides with a guiding rule.	Figure 4-16
5	Trimming of guide rails at the location of rail joints.	Figure 4-17
6	The deviation of the distance between the top faces of two guide rails.	Figure 4-18

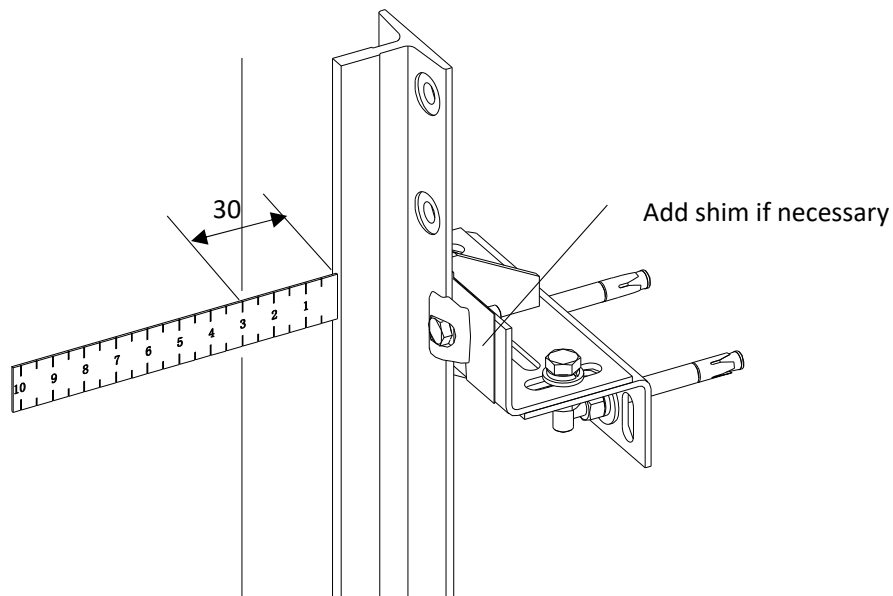

Figure 4-13

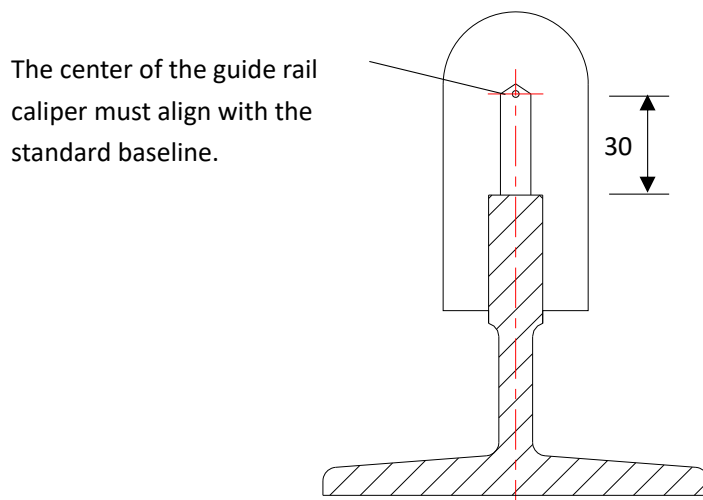

Figure 4-14



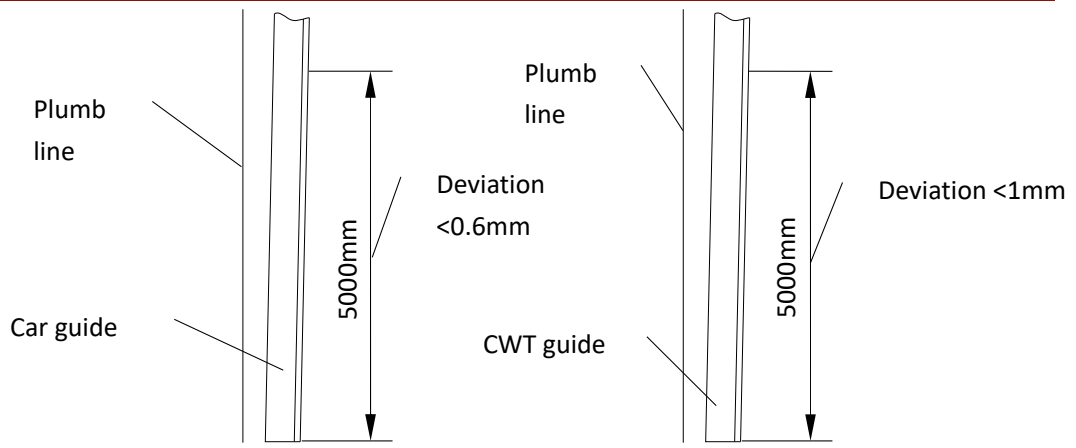

Figure 4-15

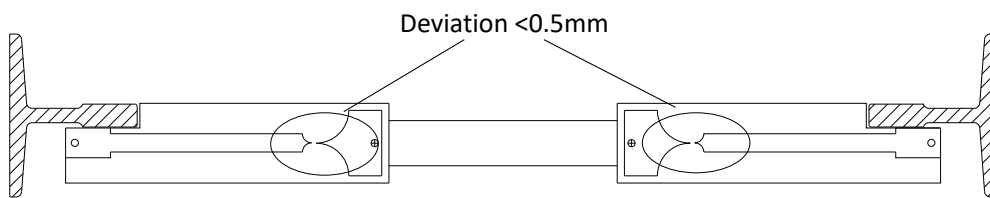

Figure 4-16

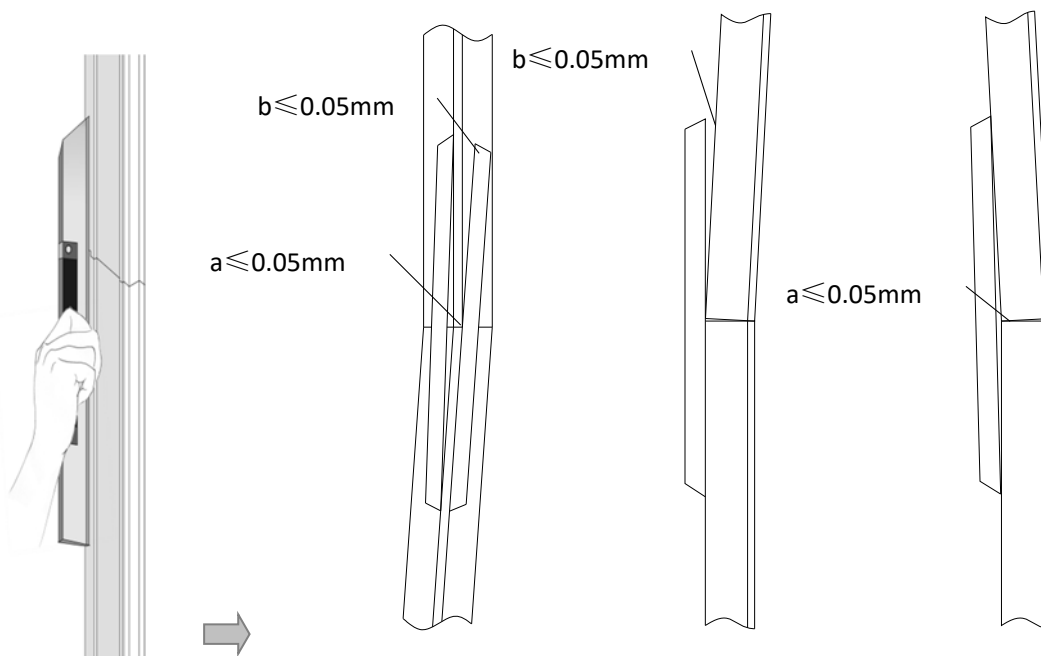

Figure 4-17

**Note:**

File the rail joint to meet the requirement above, to make sure the file length not less than 300mm.

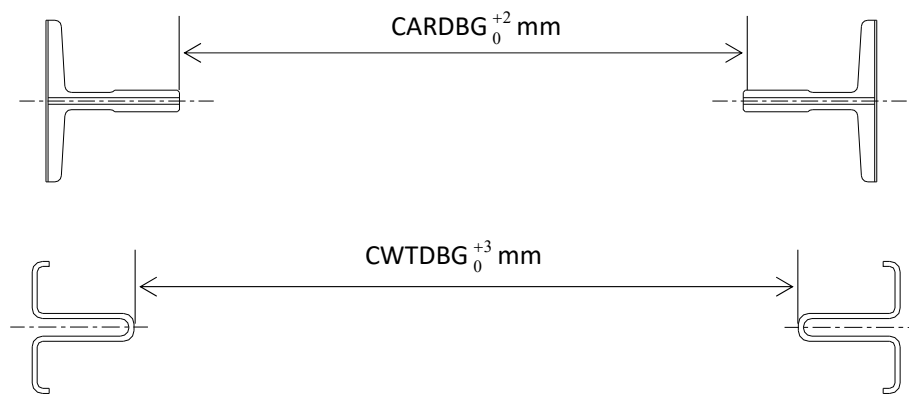

Figure 4-18

**Notes:**

1. Car guide rails or with safety gear counterweight guide rails: The Verticality of the entire column rails no more than 1.2mm; Verticality of rails per 5m no more than 0.6mm.
2. Counterweight hollow guide rails: The Verticality of the entire column rails no more than 3mm, Verticality of rails per 5m no more than 2mm; Counterweight T TYPE guide rails without safety gear: The Verticality of the entire column rails no more than 2mm, Verticality of rails per 5m no more than 1mm.
3. Rail male end shall at top.

---

**4.6 Installation of oil catcher**

Step	Instruction	Fig
1	Fix the slot of the oil catcher to the guide rail of the elevator, and the width of the slot shall be fit with that of the guide rail.	Figure 4-19

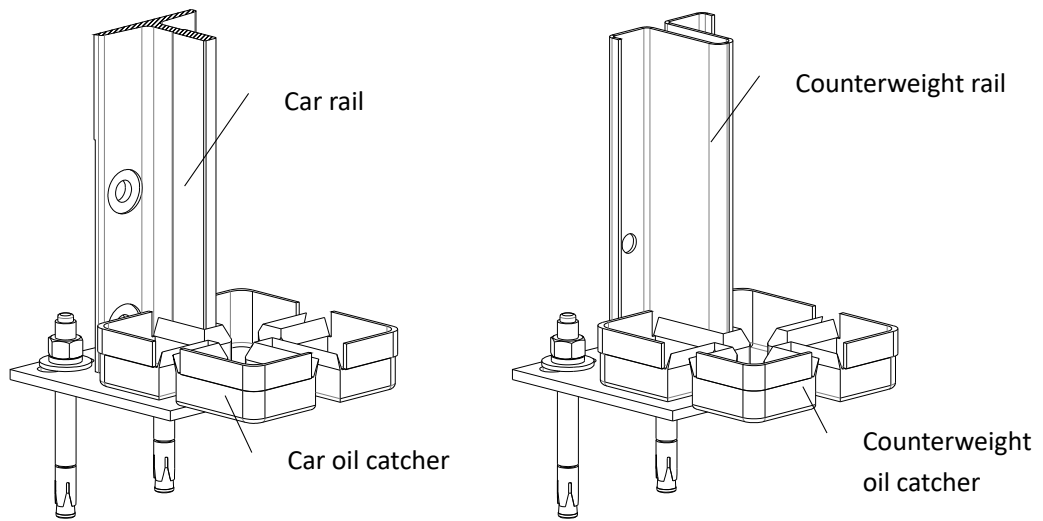
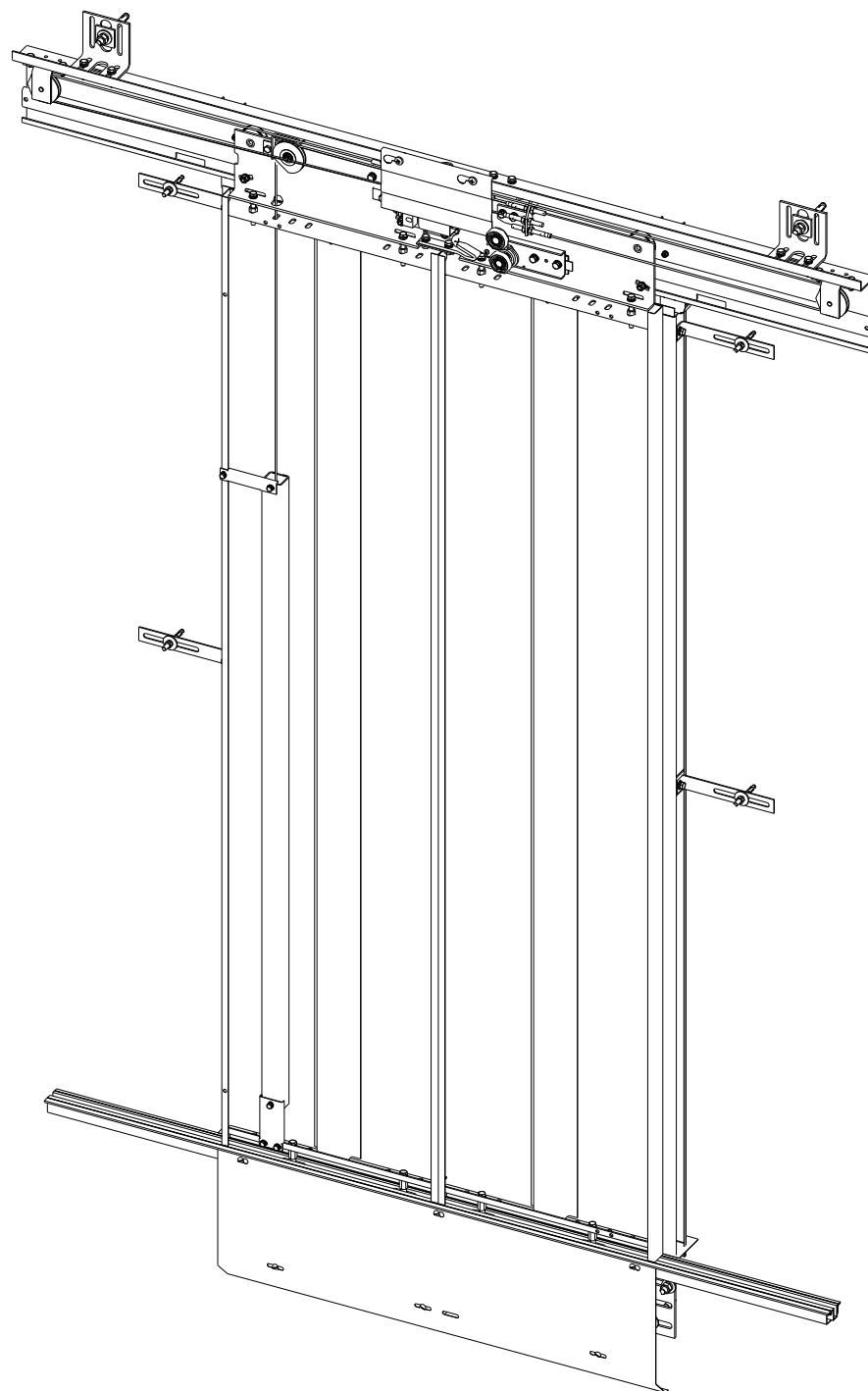

Figure 4-19

---

## 5 Installation of landing door

Landing door installation overall picture:



(CLD)

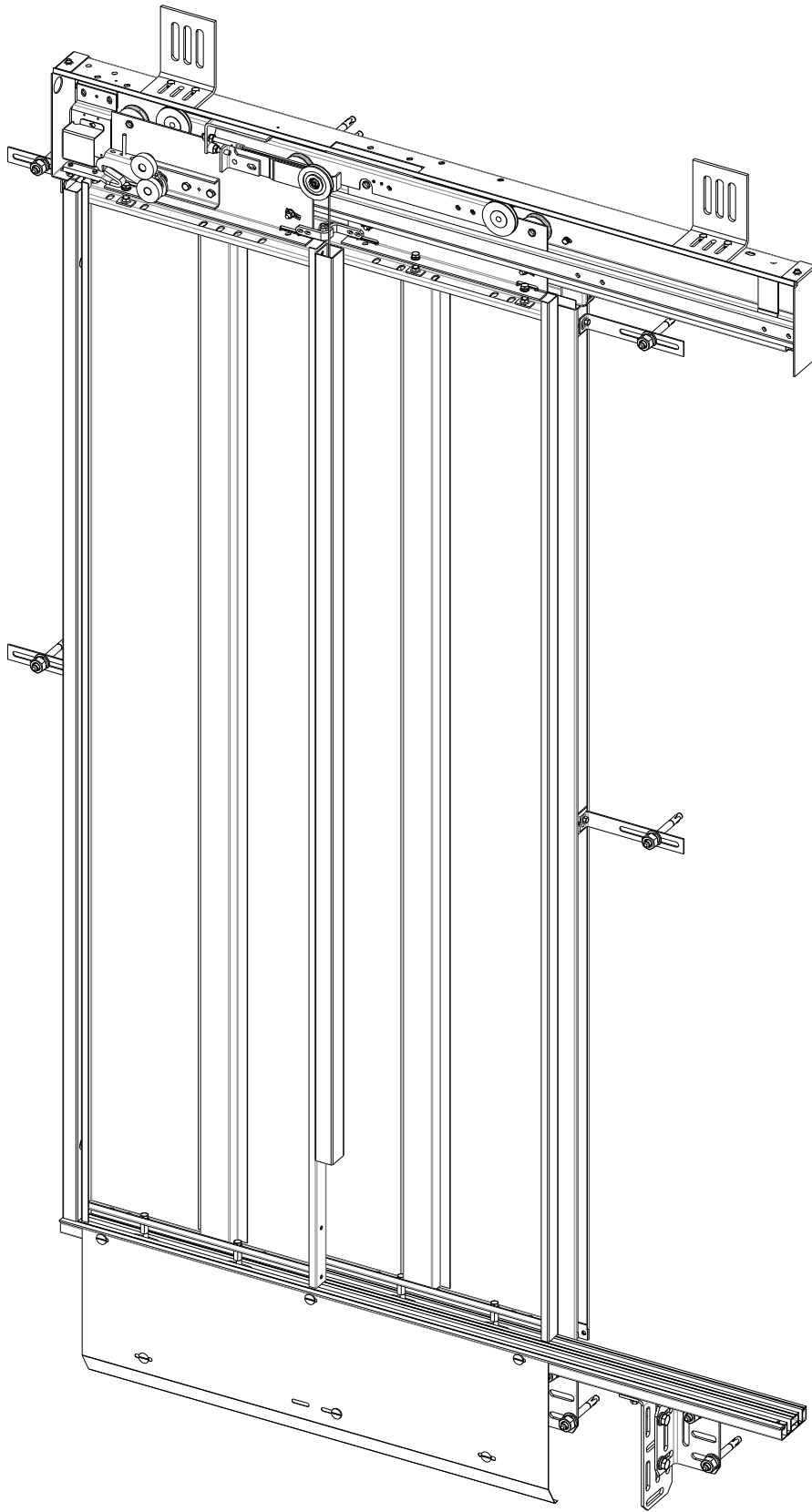

(TLD)

### 5.1 Installation of landing door sill

Step	Instruction	Fig
1	Mark door open center line and open width lines on the sill.	Figure 5-1
2	Assemble brackets and landing door sills	Figure 5-2
3	Position the landing door sill assembly in hoistway and make open width line on sill aligned with plumb line.	Figure 5-3
4	Fix sill assembly via hilti bolts on the wall, and adjust the sill so that aligning the clean opening door width lines with two plumbs for landing door.	Figure 5-4, 5-5, 5-6
5	Connect guard plate to the sill with fasteners	Figure 5-7

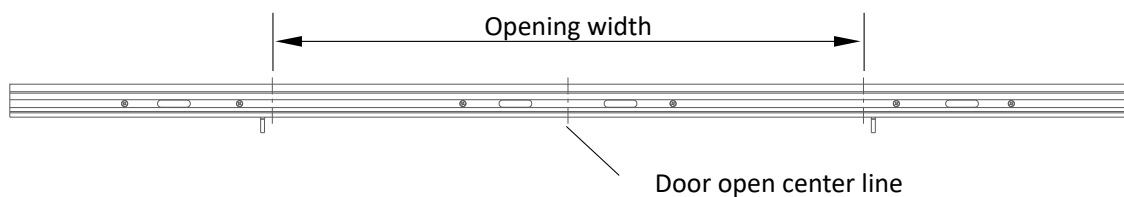

Figure 5-1(CLD)

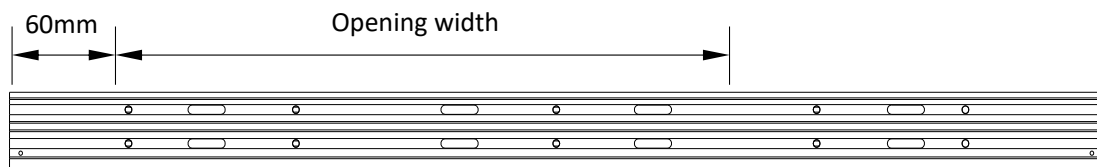

Figure 5-1(TLD)

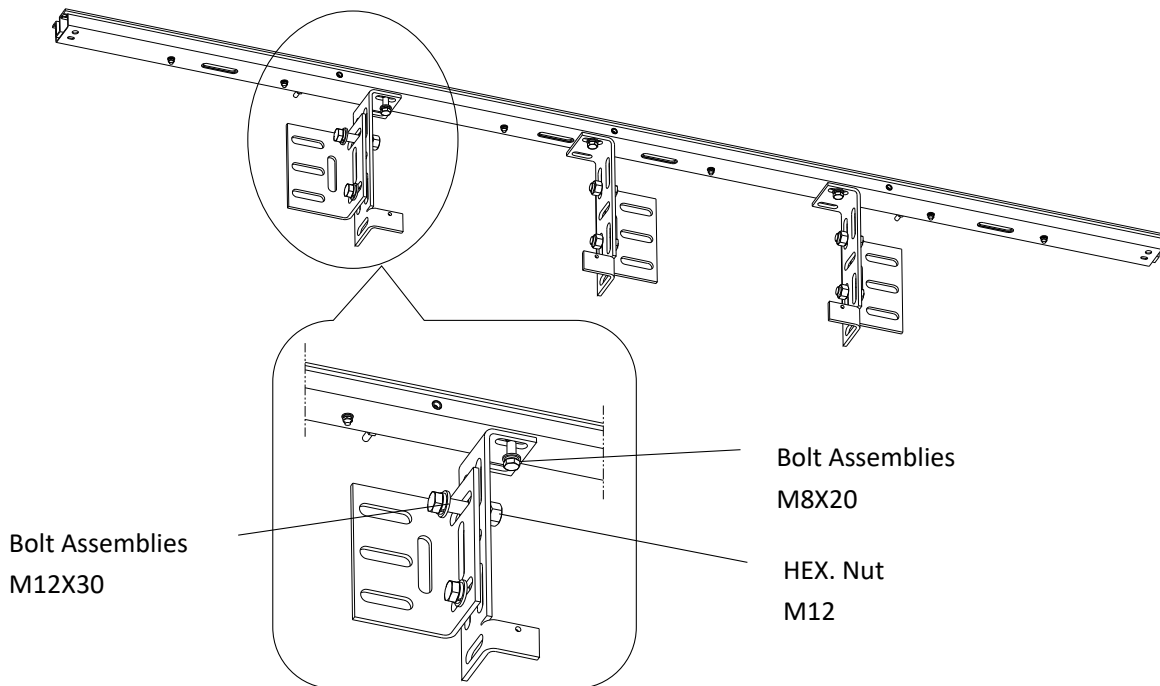

Figure 5-2(CLD)

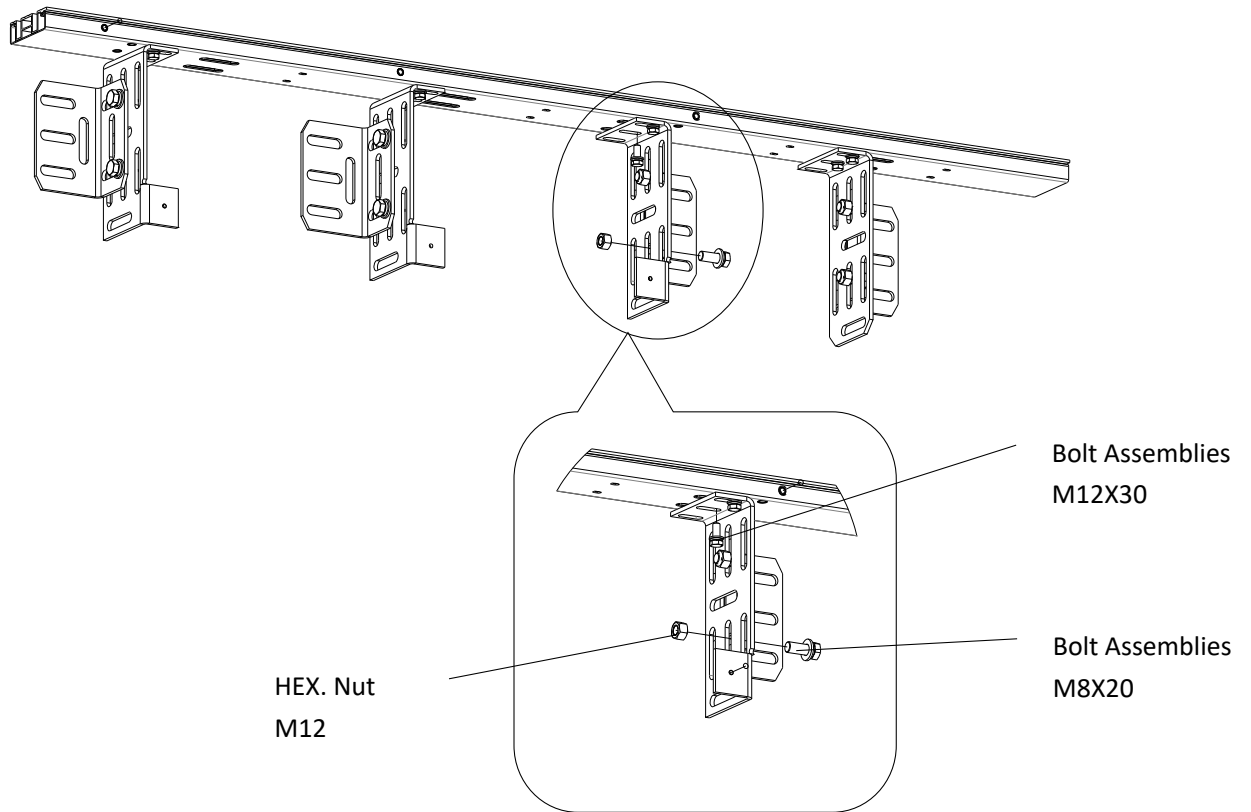

Figure 5-2(TLD)

**Note:**

After install the landing door sill, the sill surface should be 0-3mm higher than the ground level of landing door decoration.

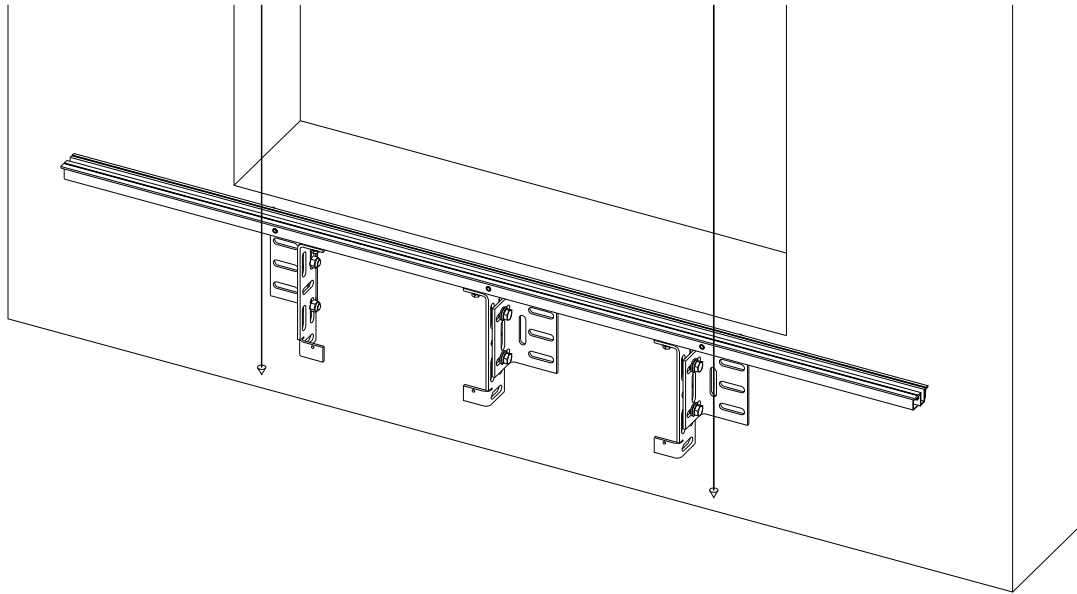

Figure 5-3(CLD)

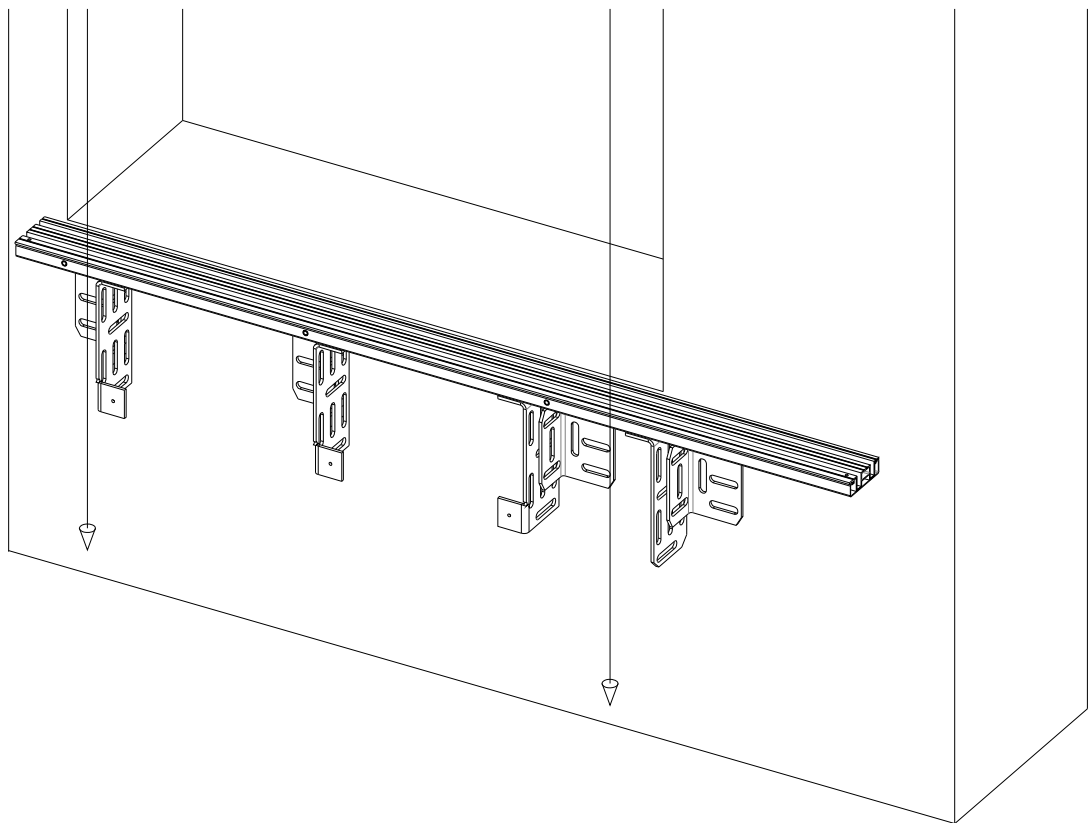

Figure 5-3(TLD)



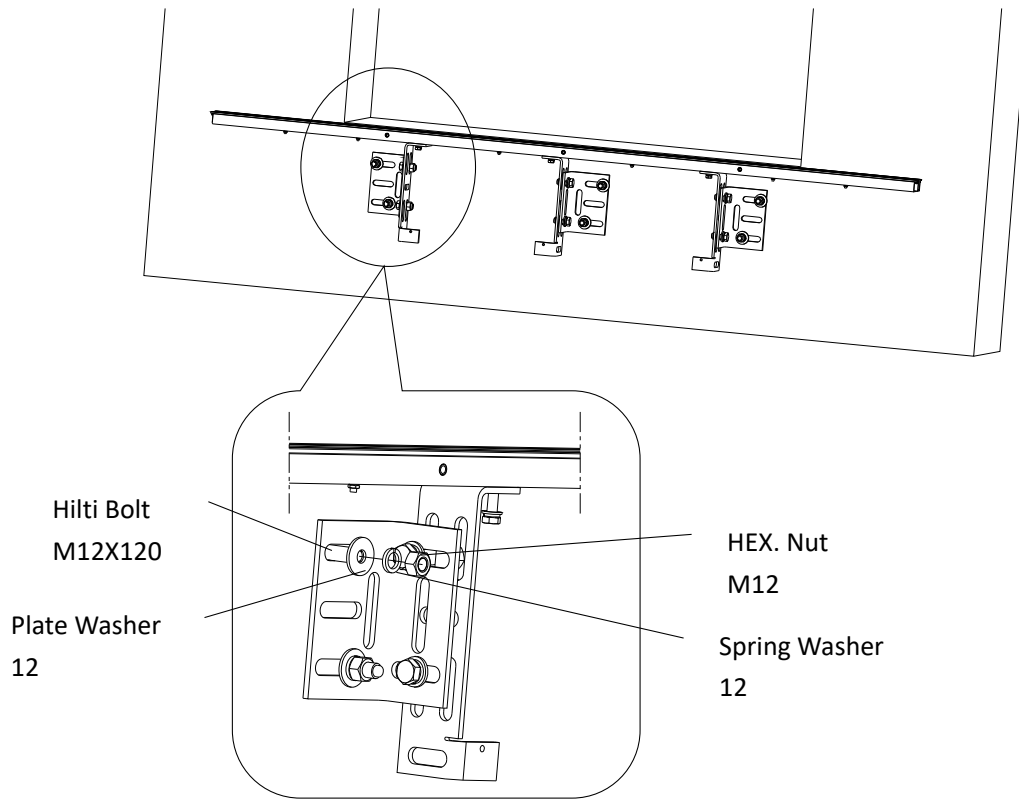

Figure 5-4(CLD)

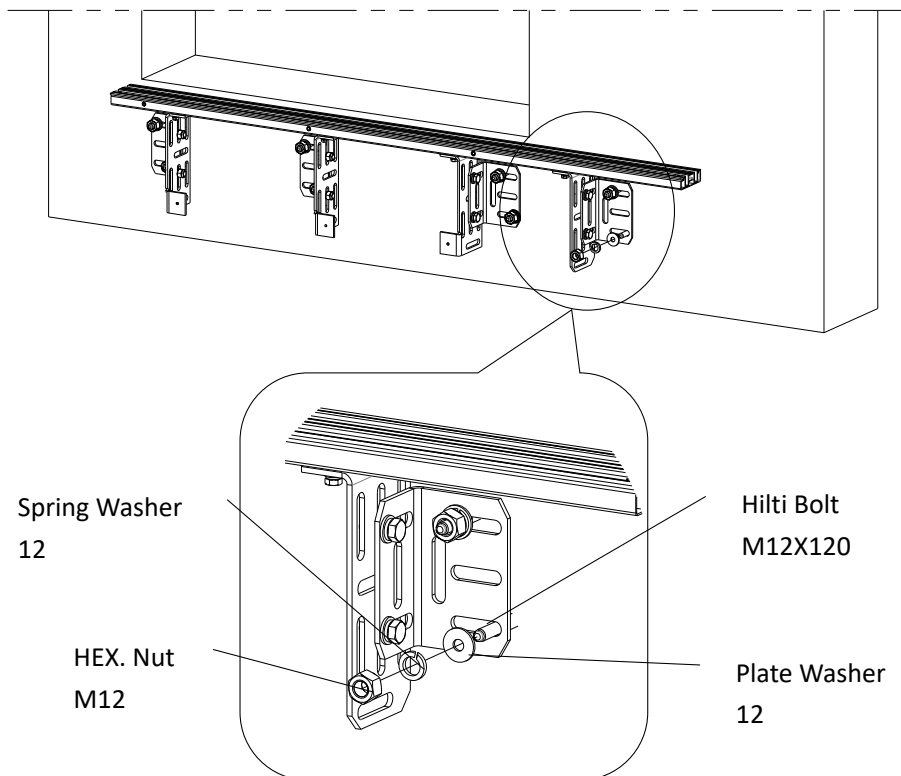

Figure 5-4(TLD)

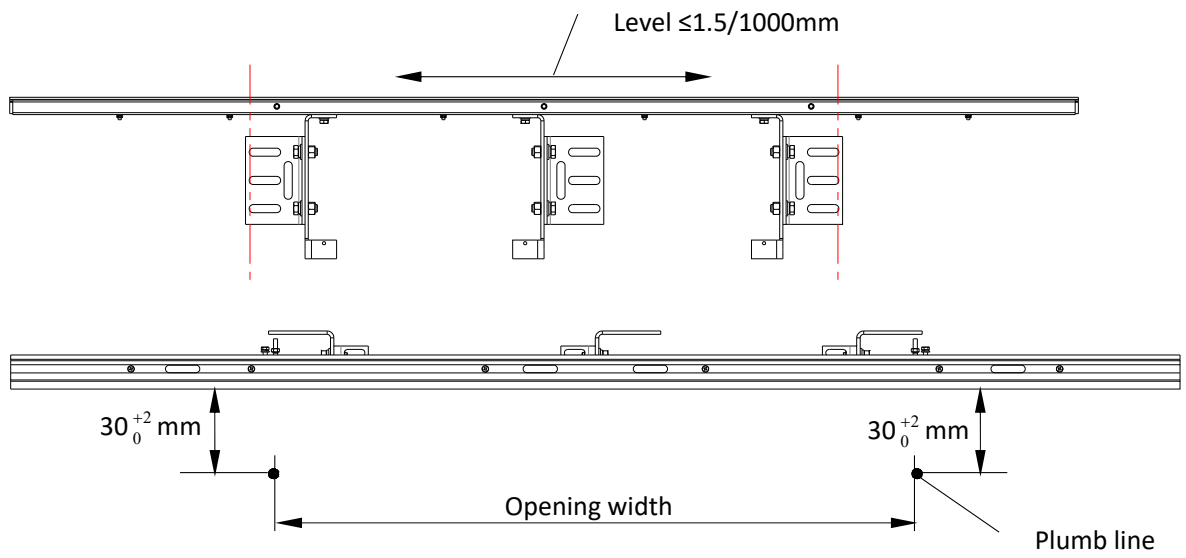

Figure 5-5(CLD)

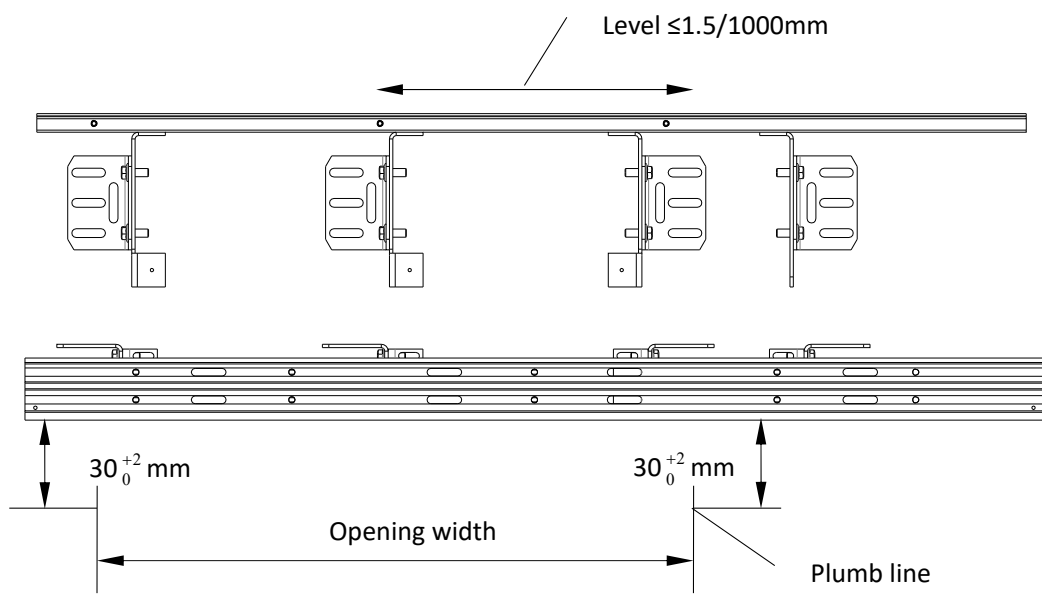
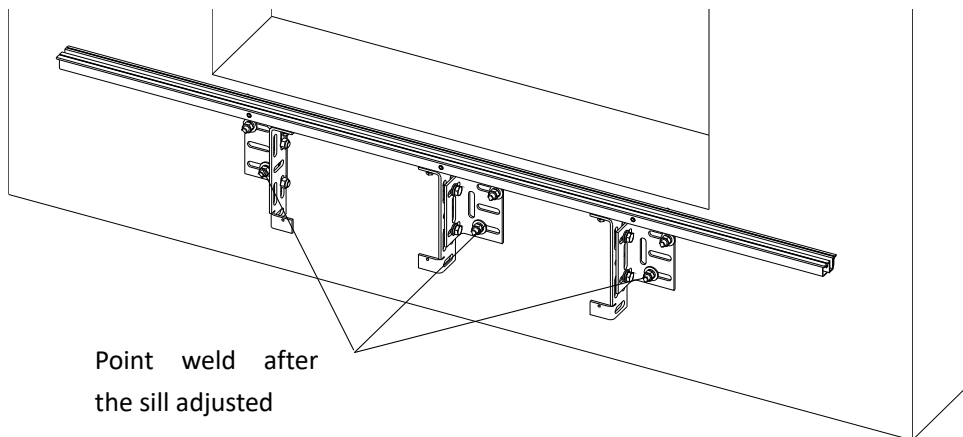
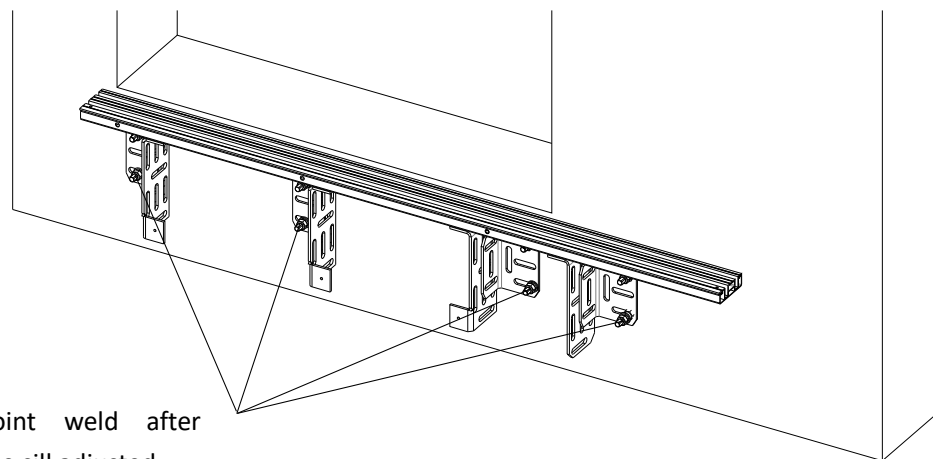

Figure 5-5(TLD)



Point weld after  
the sill adjusted

Figure 5-6(CLD)



Point weld after  
the sill adjusted

Figure 5-6(TLD)

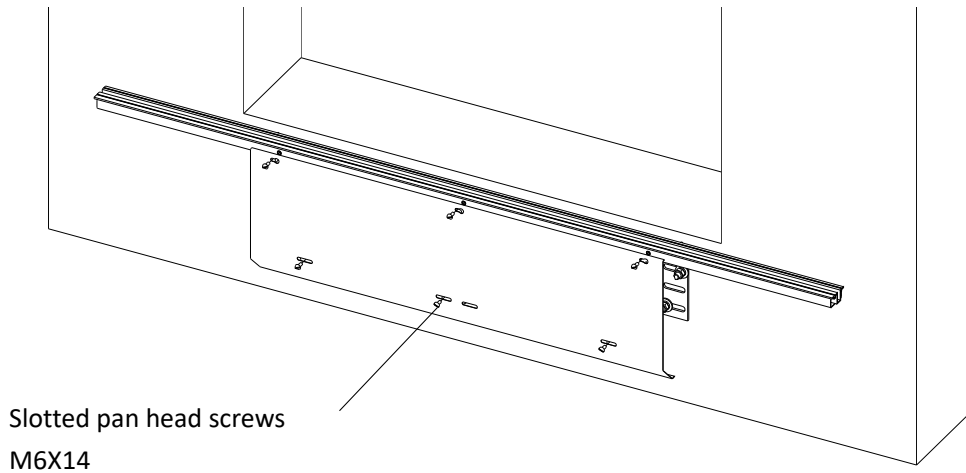

Figure 5-7(CLD)

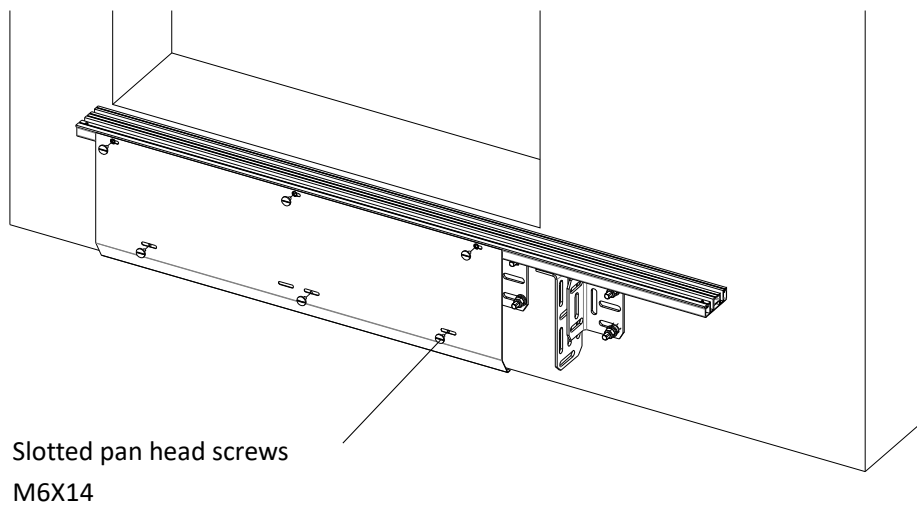

Figure 5-7(TLD)

## 5.2 Installation of landing door jamb

Step	Instruction	Fig
1	Assembly landing door jamb at landing.	Figure 5-8
2	Connect the jamb to the sill.	Figure 5-9
3	Connect the jamb on the well wall.	Figure 5-10

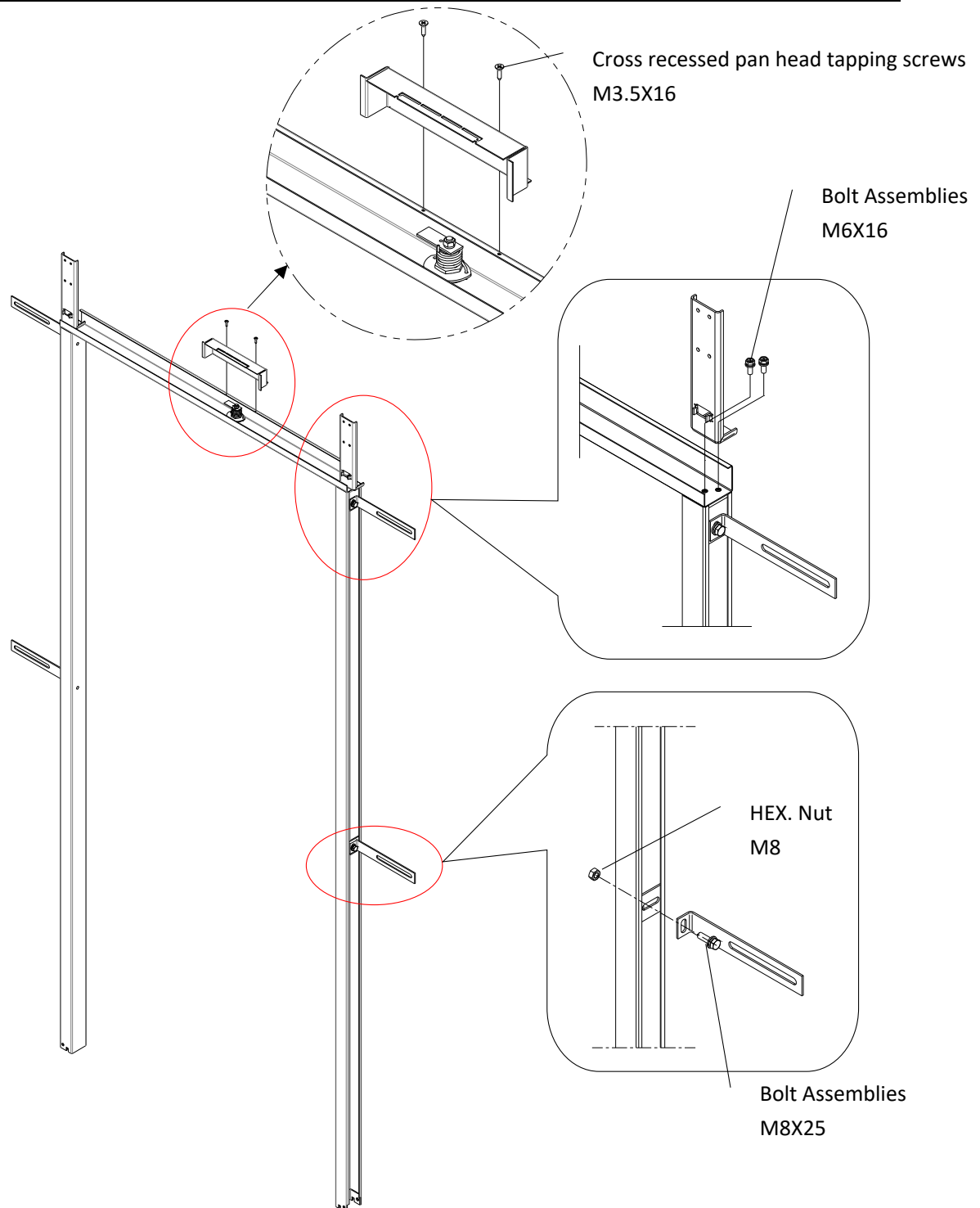

Figure 5-8(CLD)

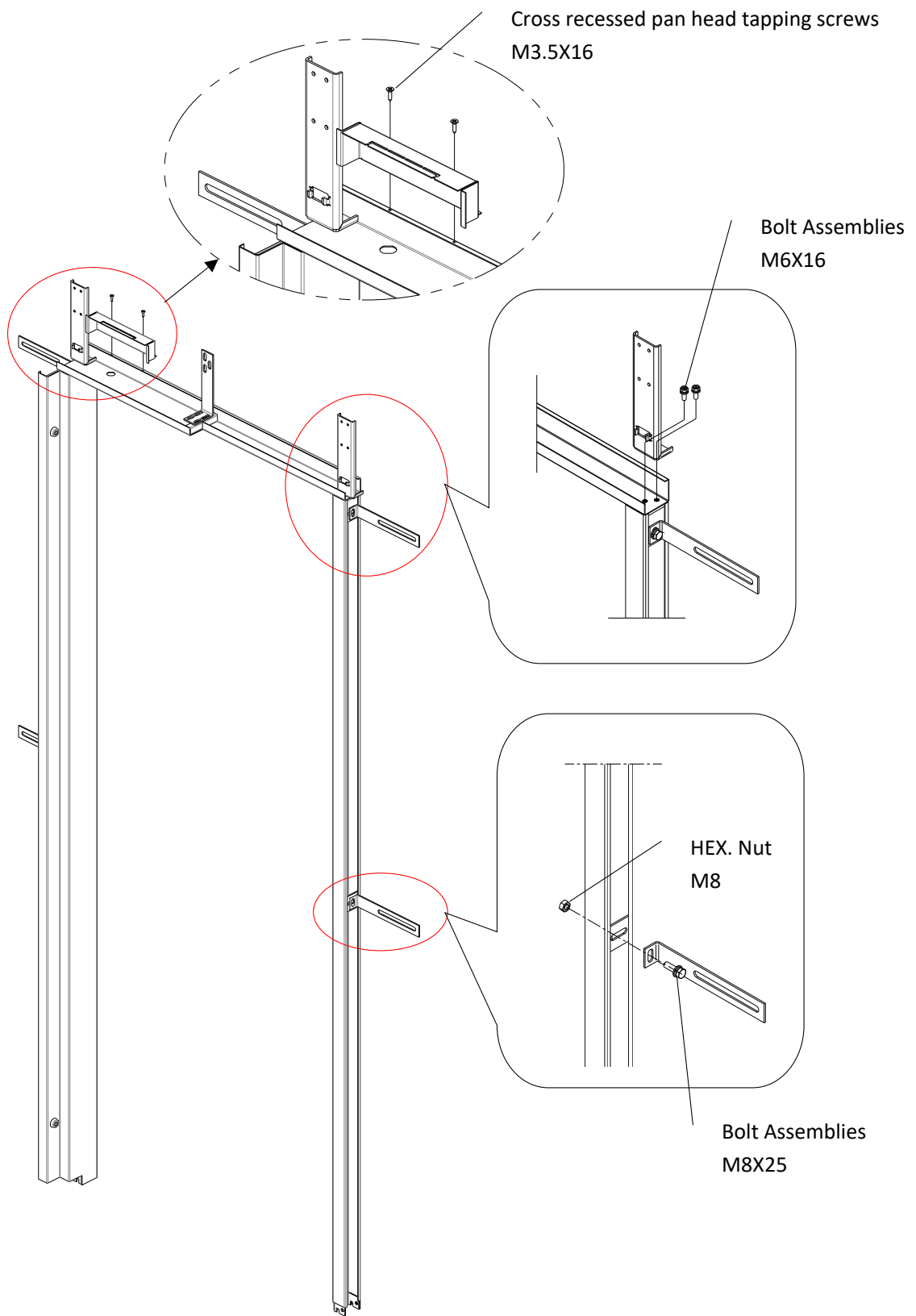

Figure 5-8(TLD)

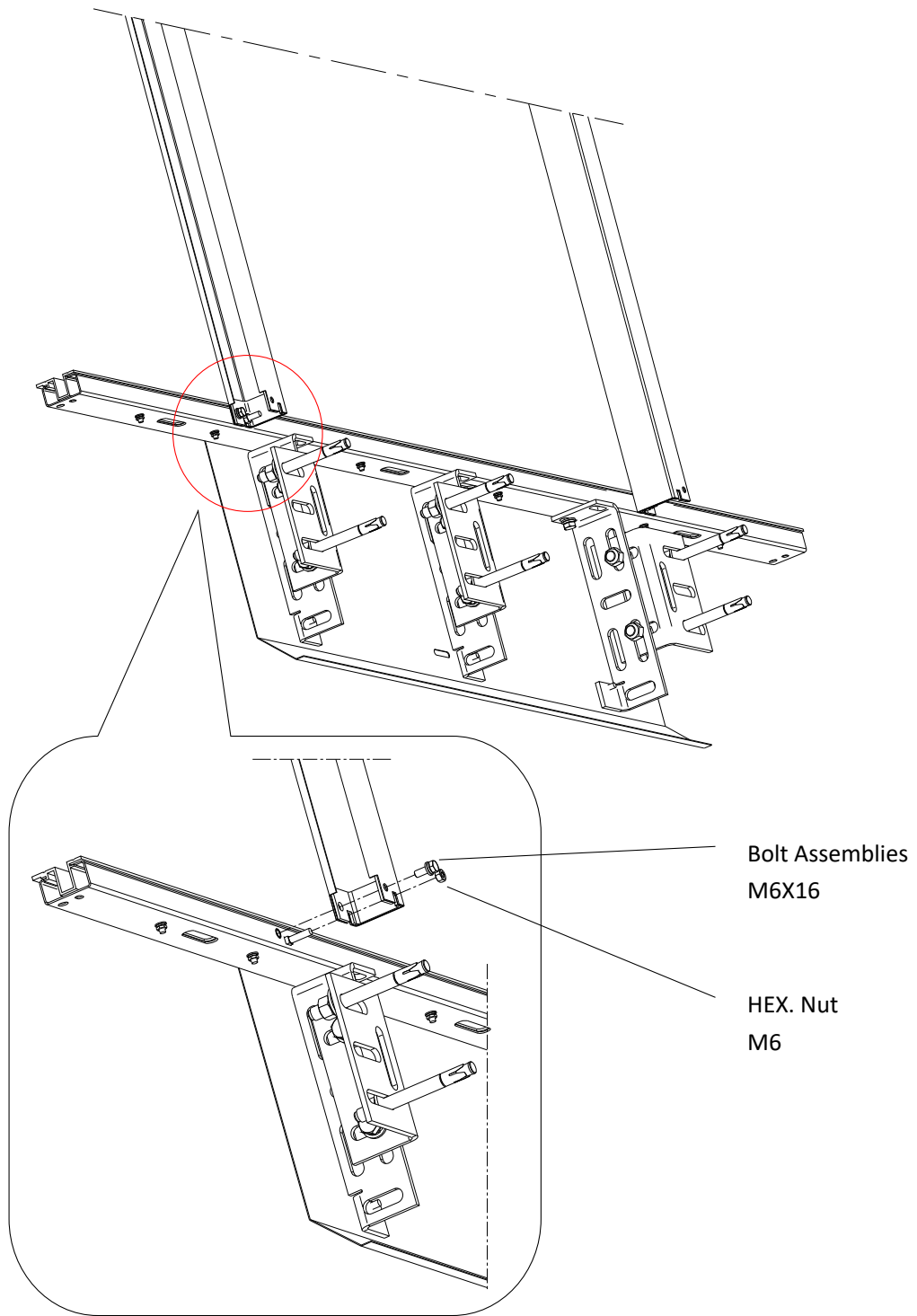

Figure 5-9(CLD)

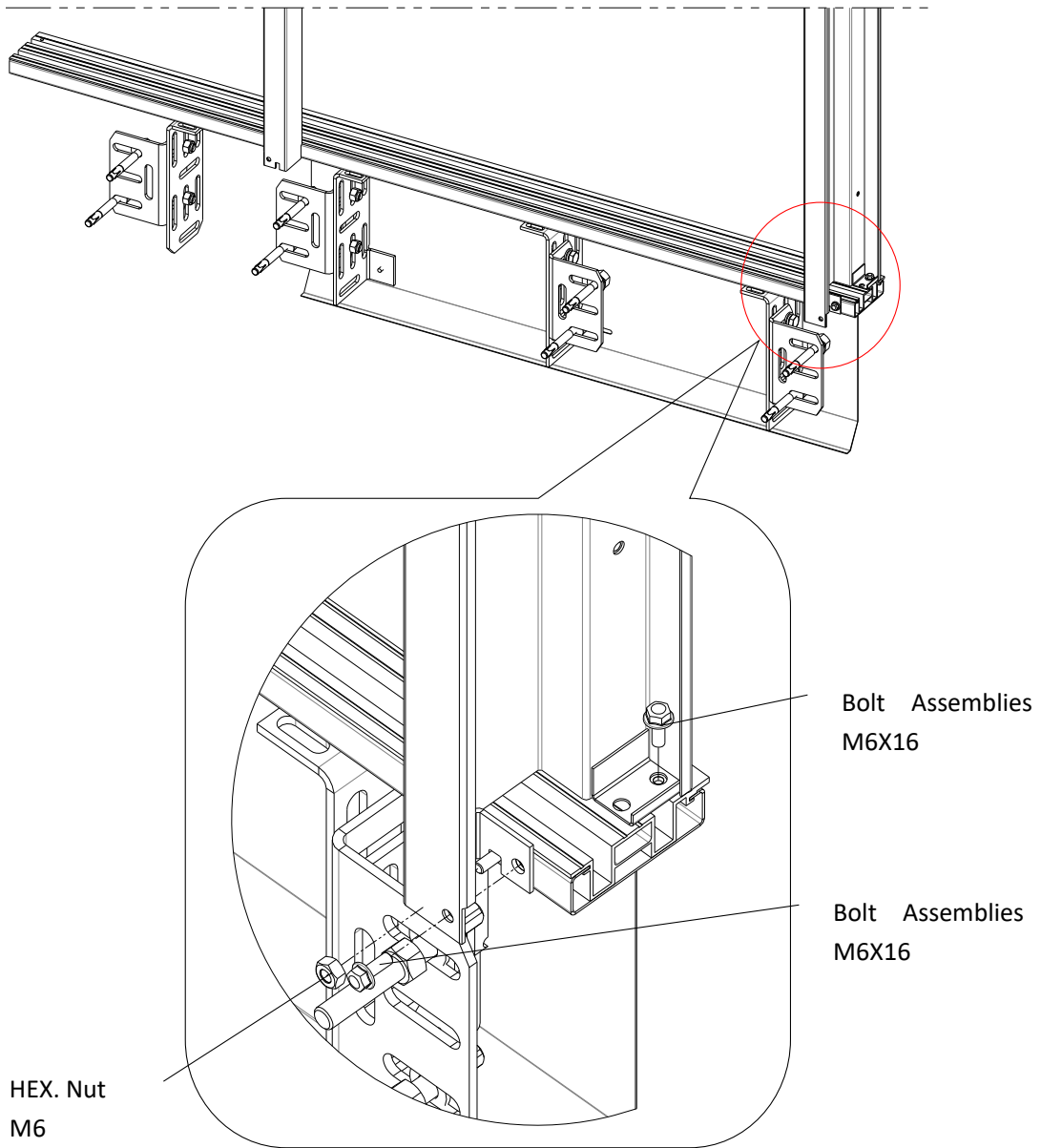

Figure 5-9(TLD)



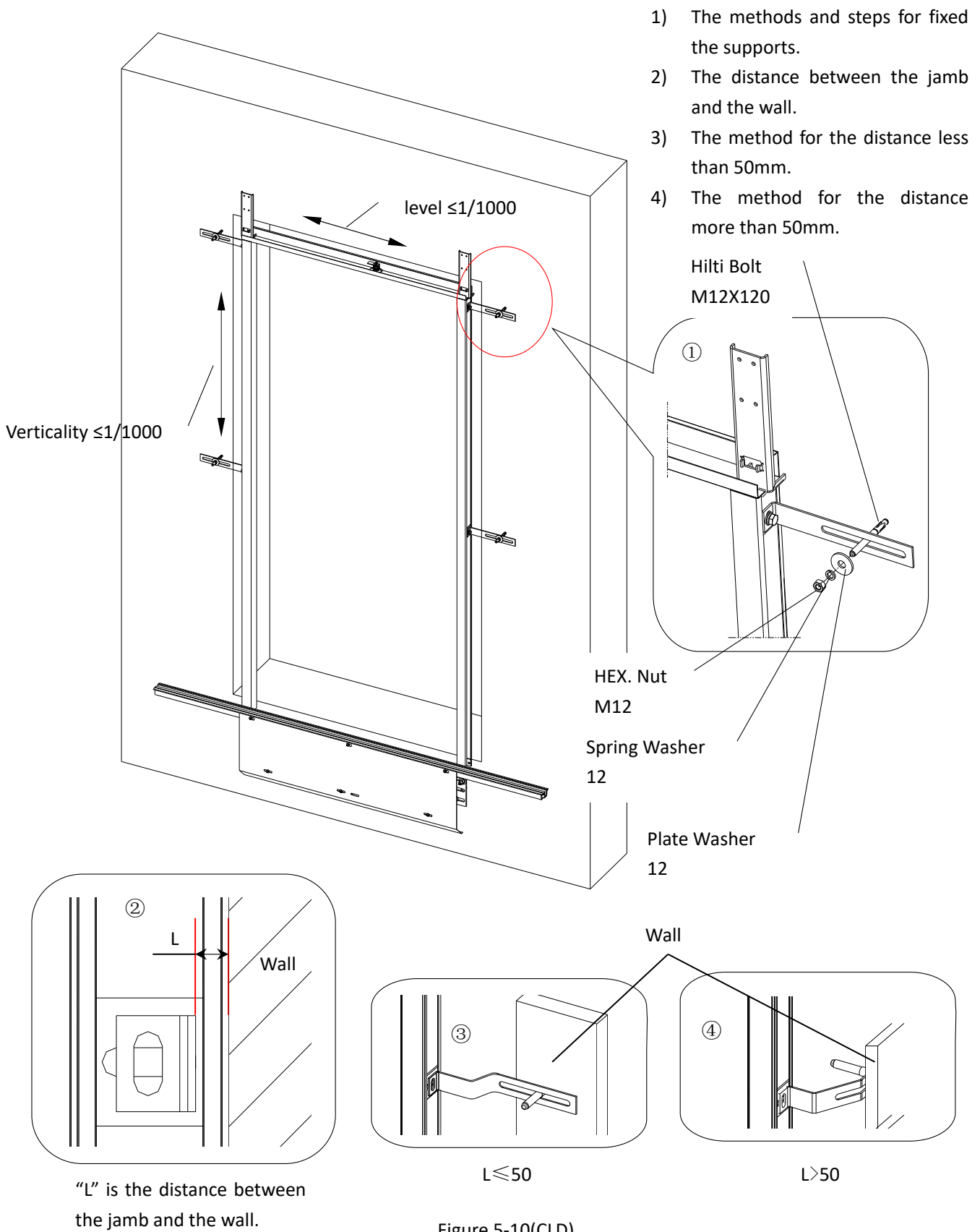
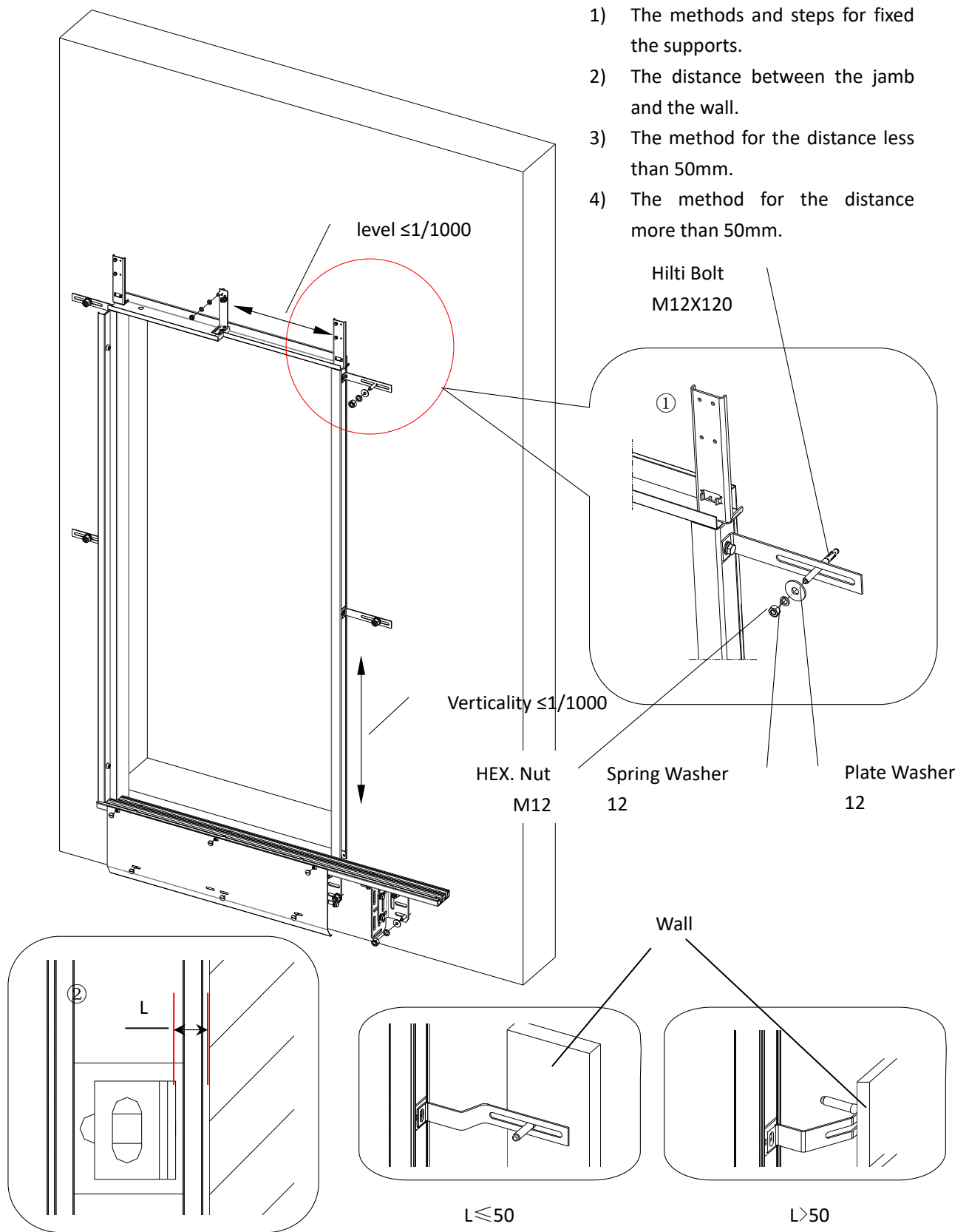

Figure 5-10(CLD)



- 1) The methods and steps for fixed the supports.
- 2) The distance between the jamb and the wall.
- 3) The method for the distance less than 50mm.
- 4) The method for the distance more than 50mm.

"L" is the distance between the jamb and the wall.

Figure 5-10(TLD)

### 5.3 Installation of landing door header

Step	Instruction	Fig
1	Assemble the brackets to the landing door header.	Figure 5-11
1	Connect the landing door header to the door jamb.	Figure 5-12
2	Connect the landing door header on the well wall.	Figure 5-13
3	Adjust the landing door header.	Figure 5-14

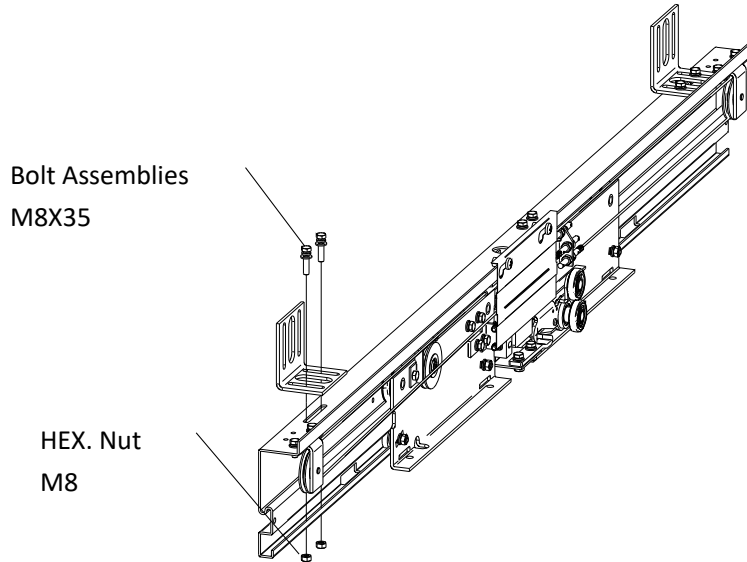

Figure 5-11(CLD)

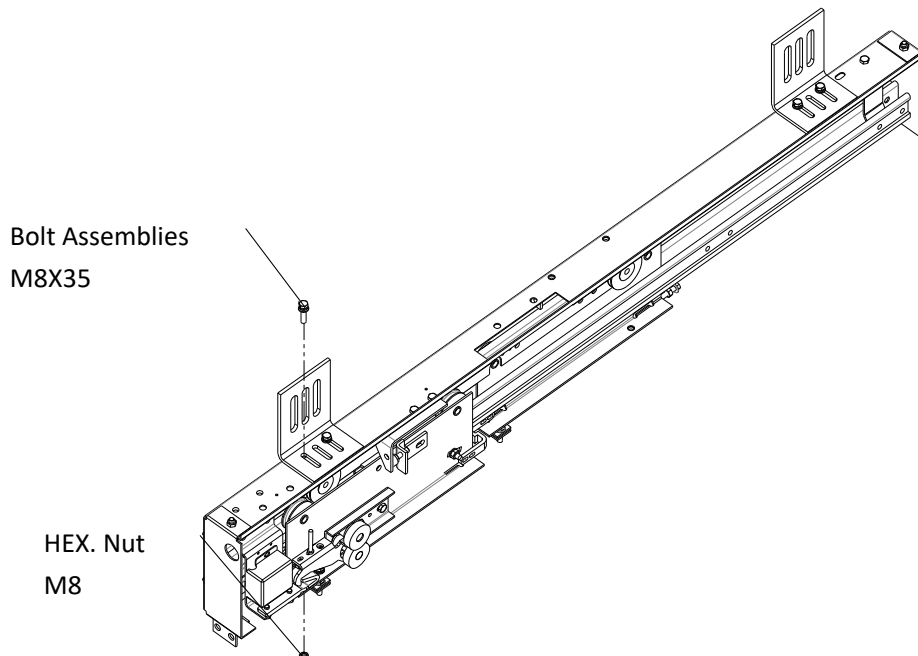

Figure 5-11(TLD)

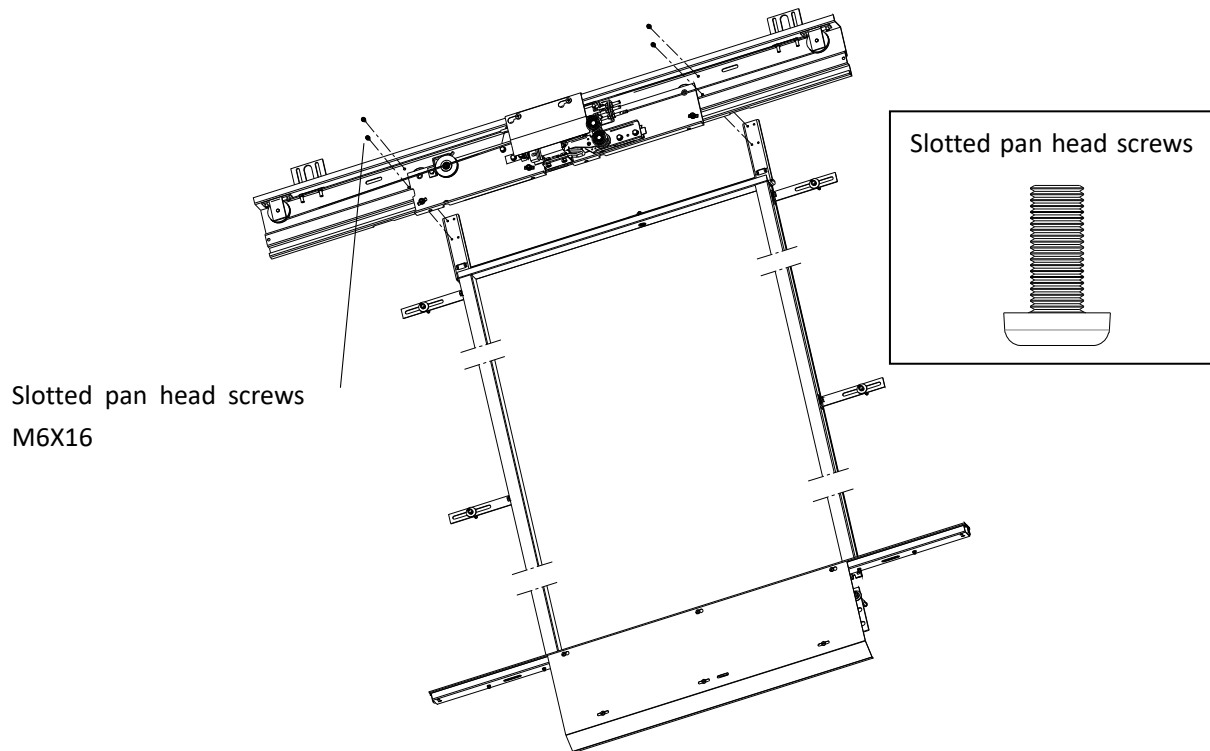

Figure 5-12(CLD)

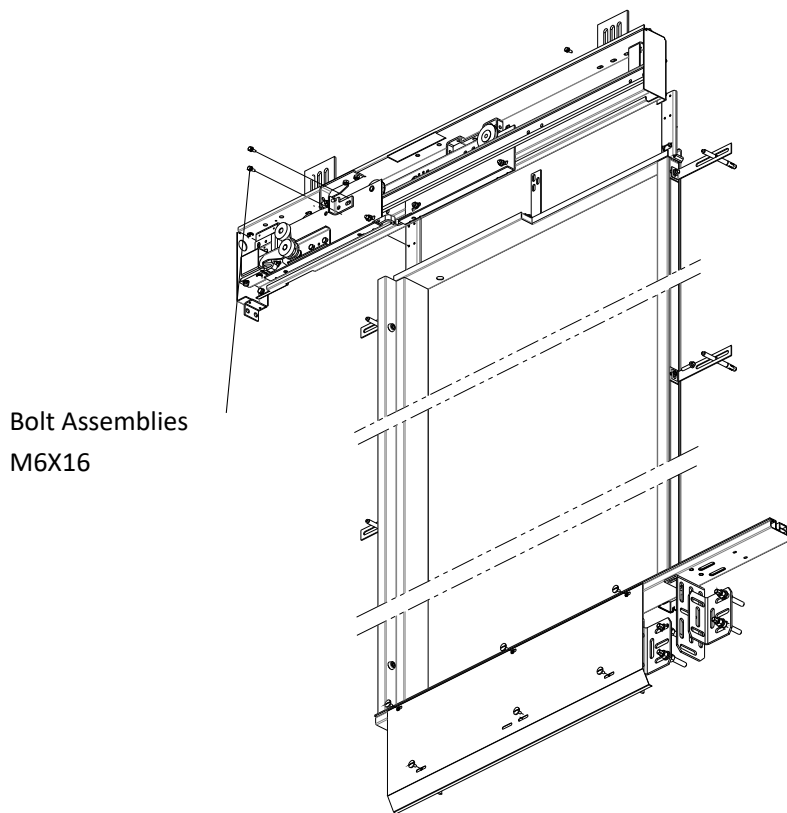

Figure 5-12(TLD)

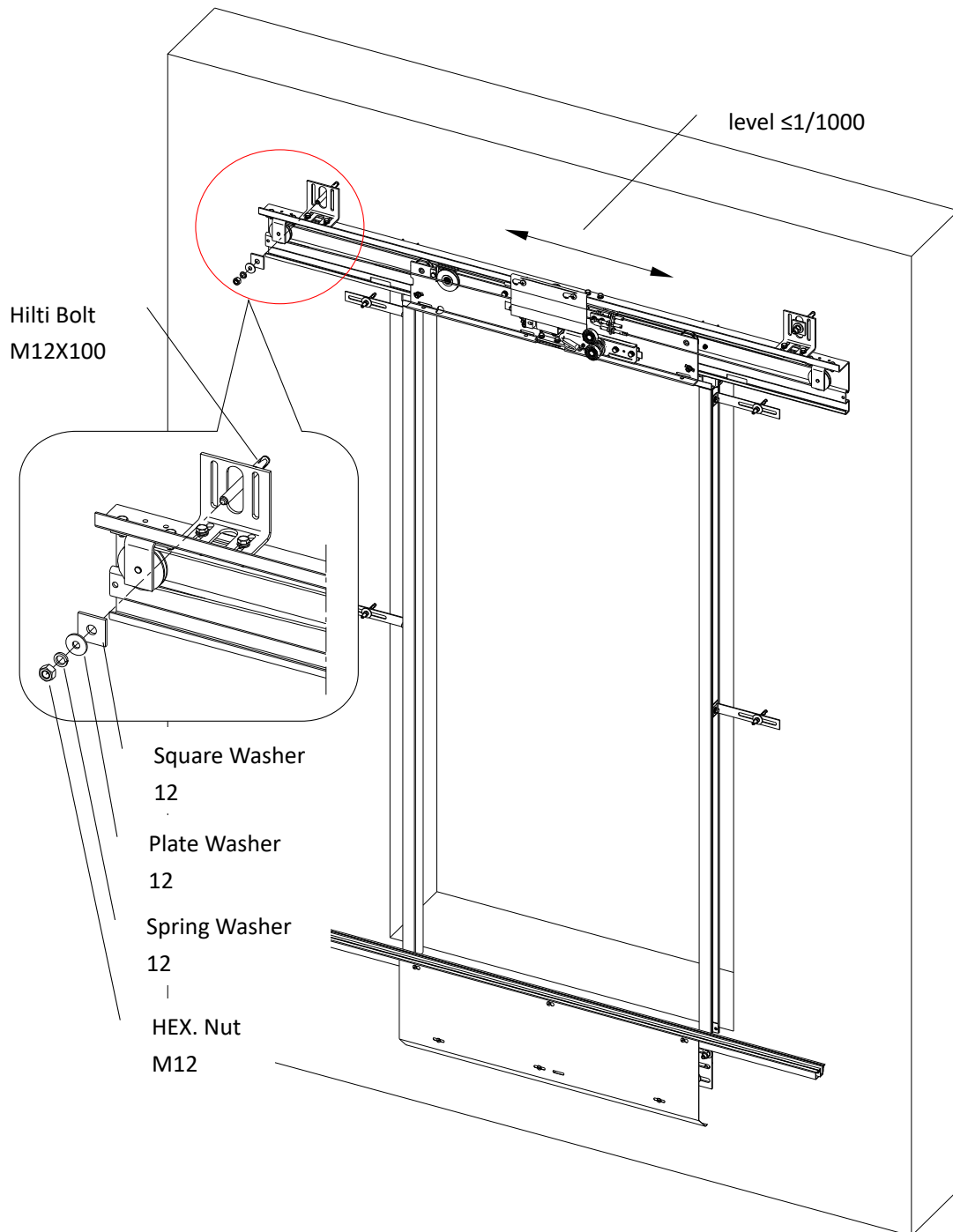

Figure 5-13(CLD)

**Note:**

When installing the landing door header, the landing door header center and door open center and sill center should be center-aligned.

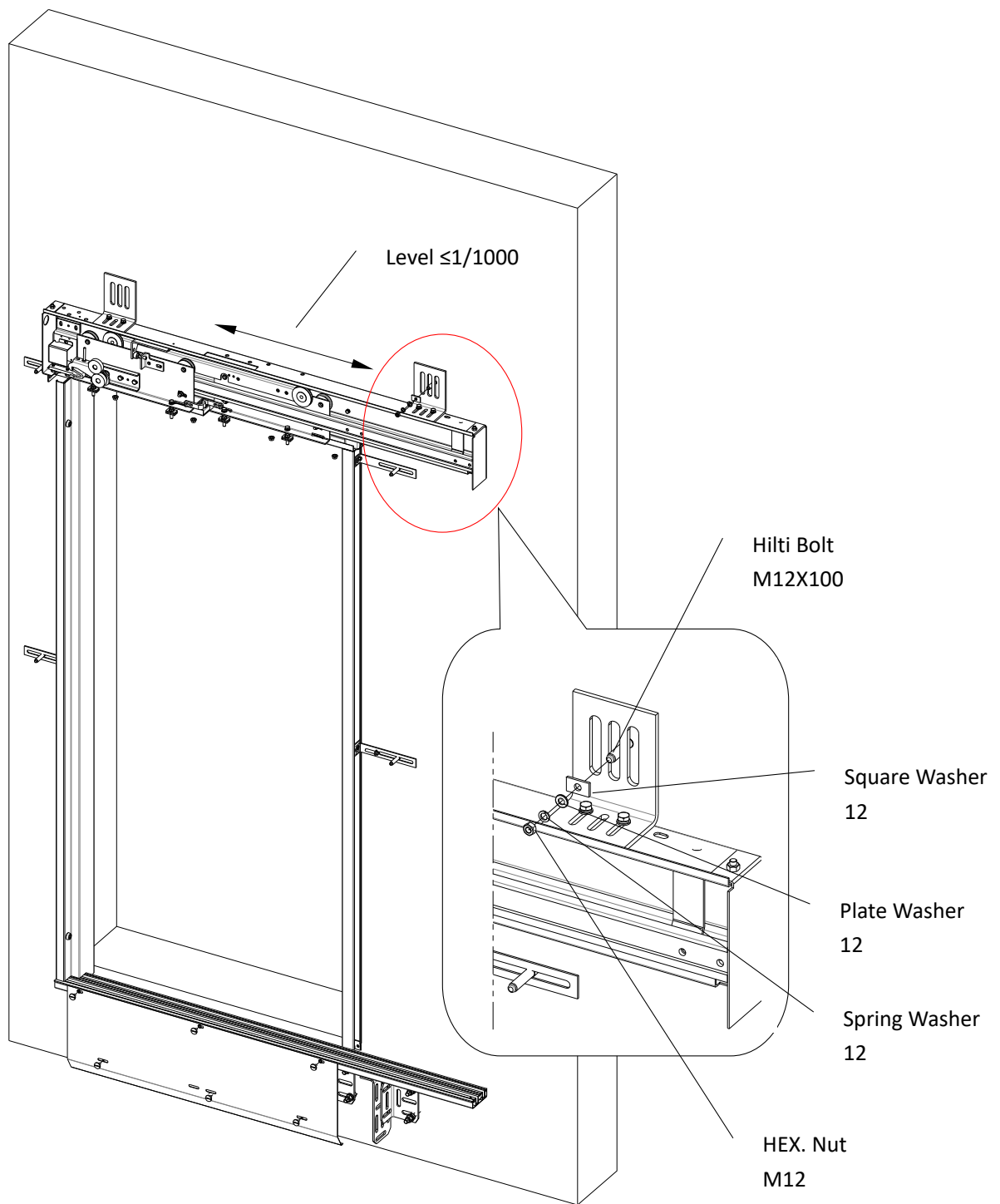

Figure 5-13(TLD)

**Note:**

When installing the landing door header, the landing door header center and door open center and sill center should be center-aligned.

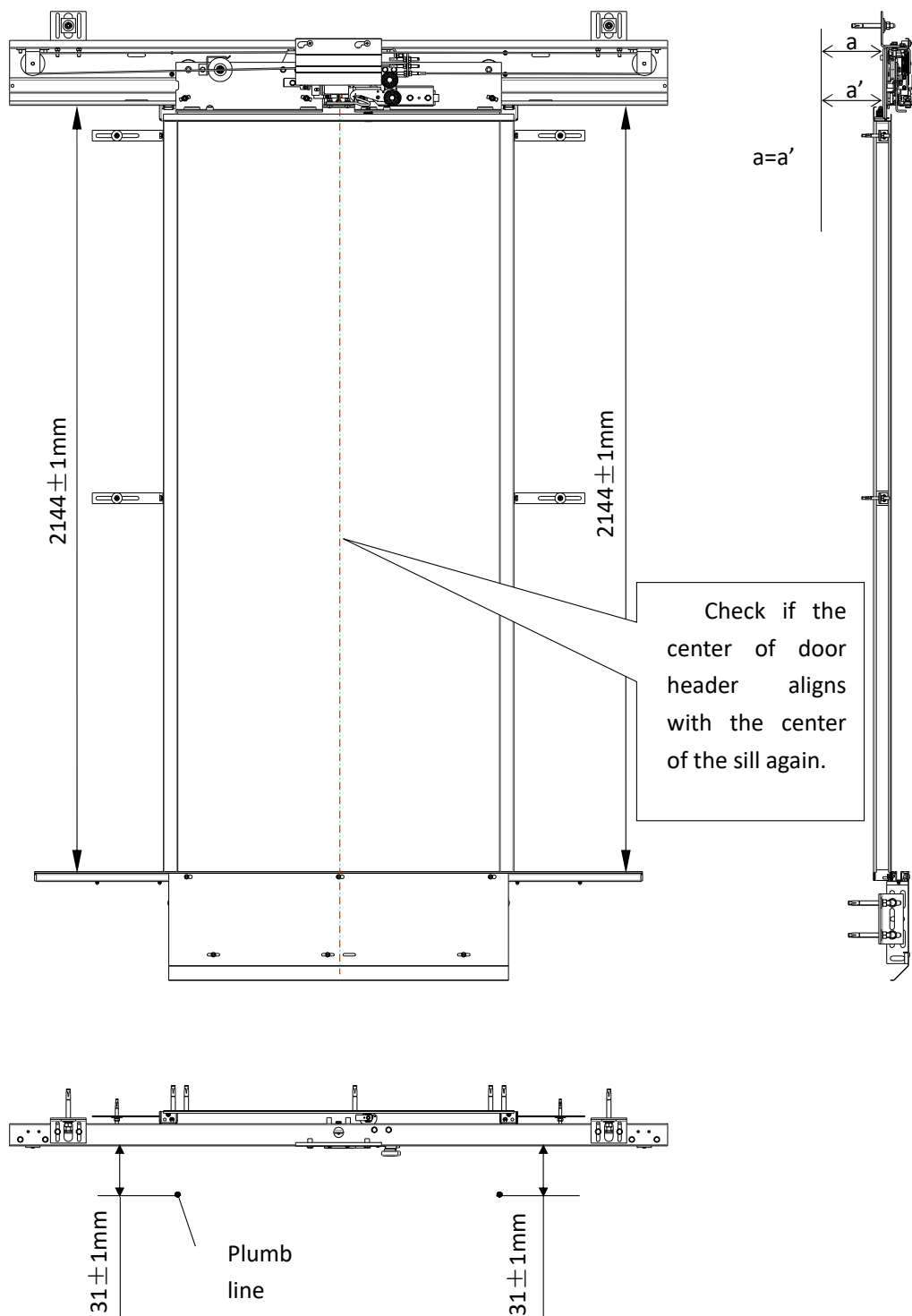

Figure 5-14(CLD)

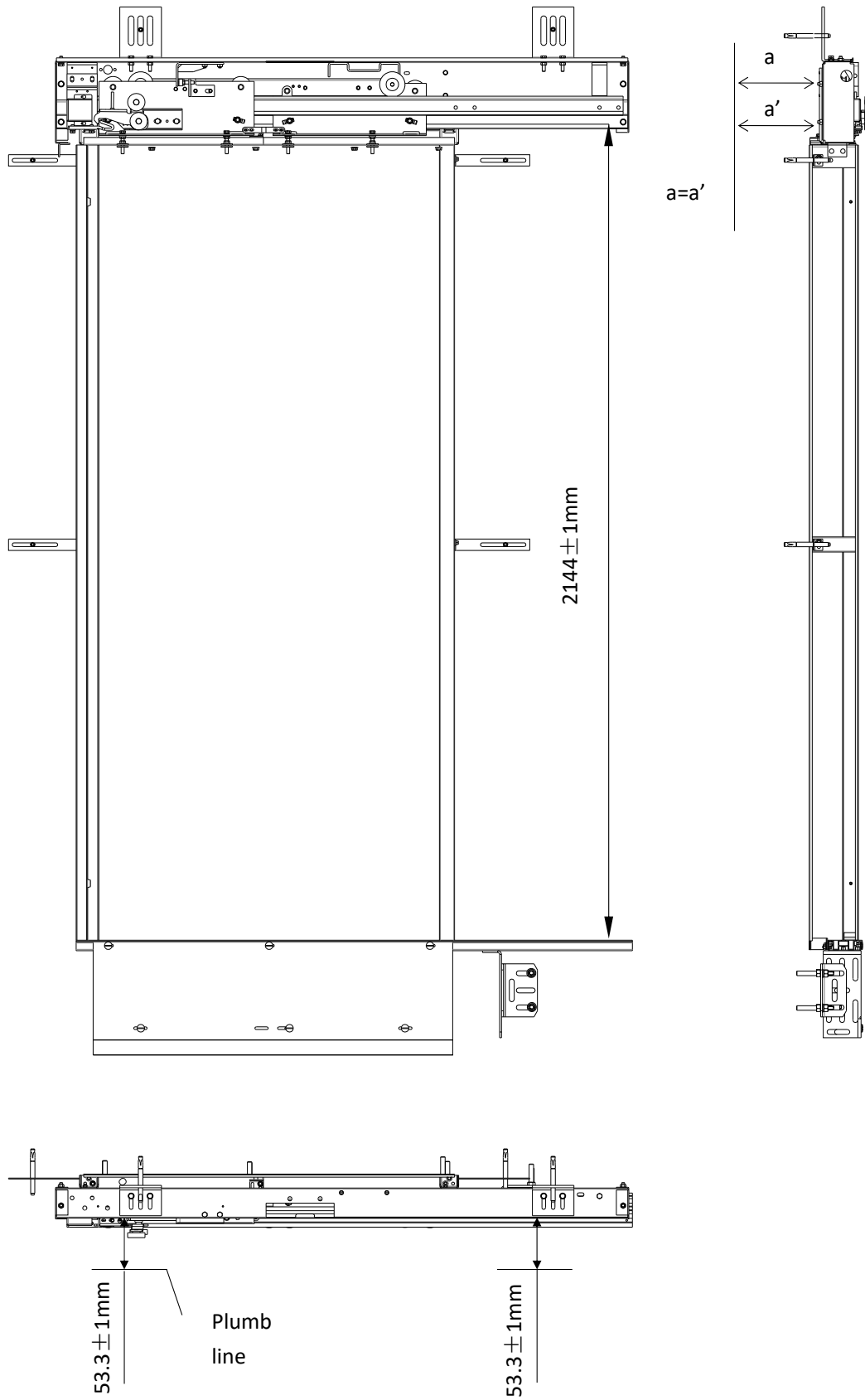

Figure 5-14(TLD)



### 5.4 Installation of landing door panel

Step	Instruction	Fig
1	Connect the door close weight guide tube.	Figure 5-15
2	Connect landing door panel to door header and assemble guide shoes.	Figure 5-16
3	Install another panel by same way.	N/A
4	Adjust the door panel.	Figure 5-17

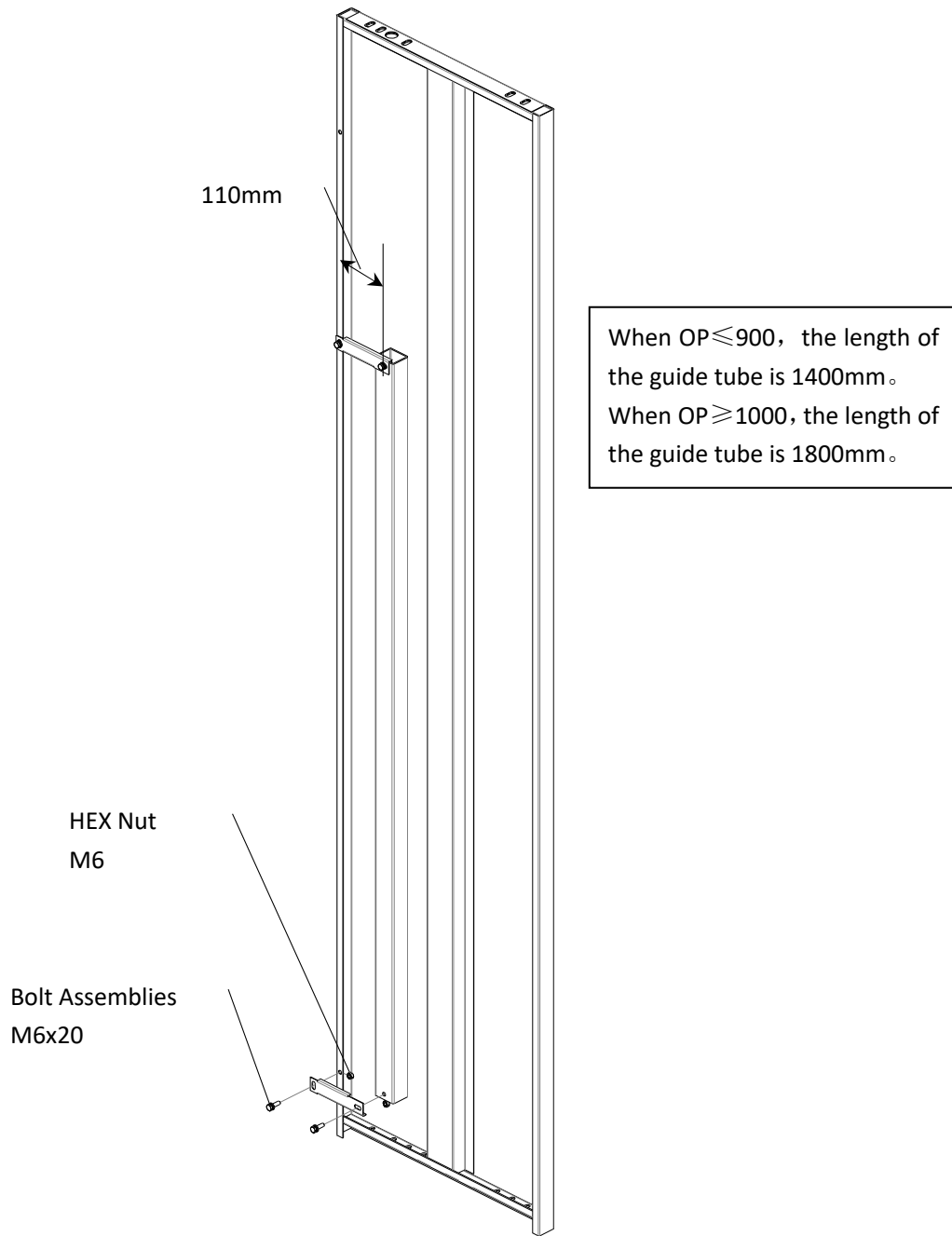

Figure 5-15(CLD)

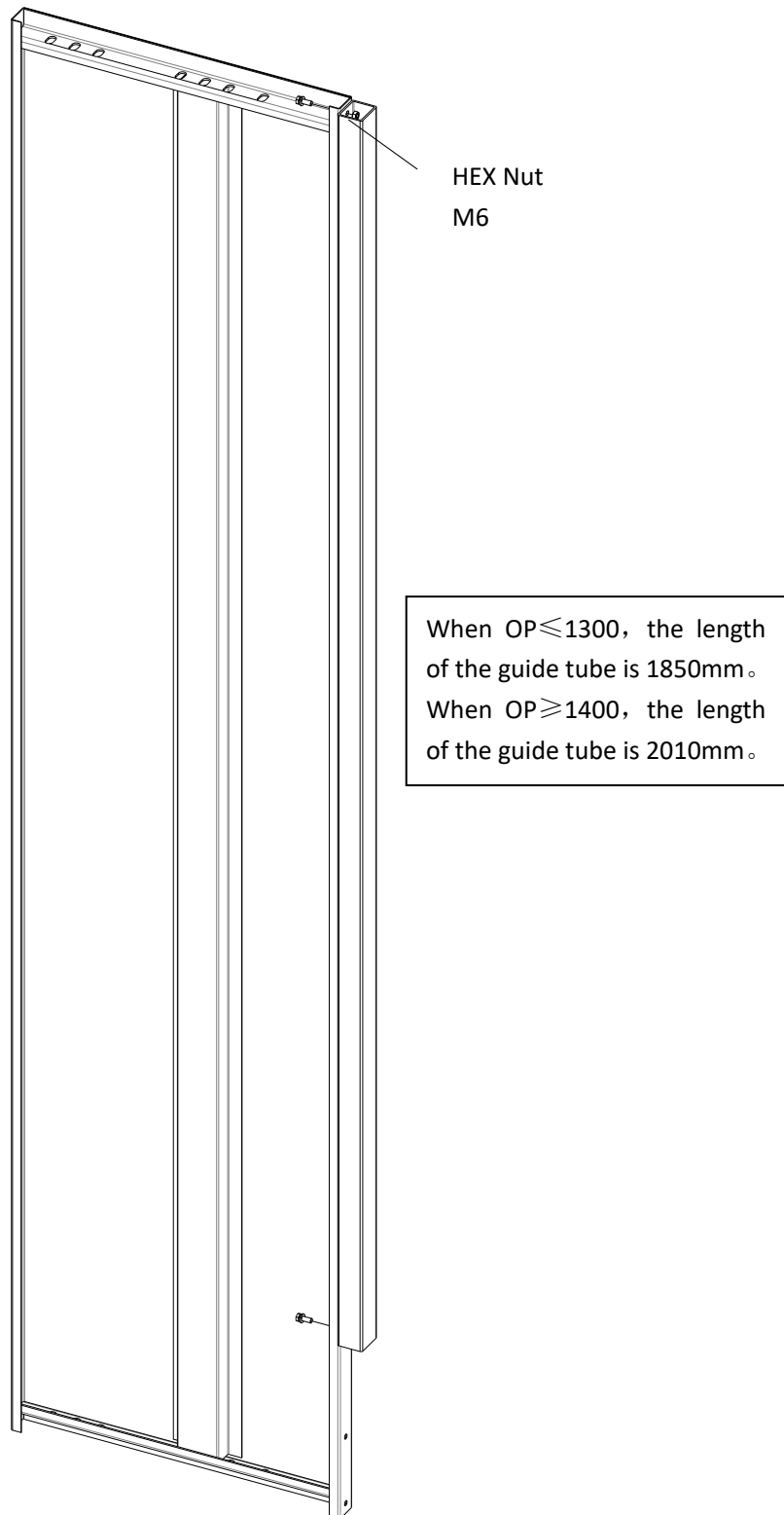

Figure 5-15(TLD)

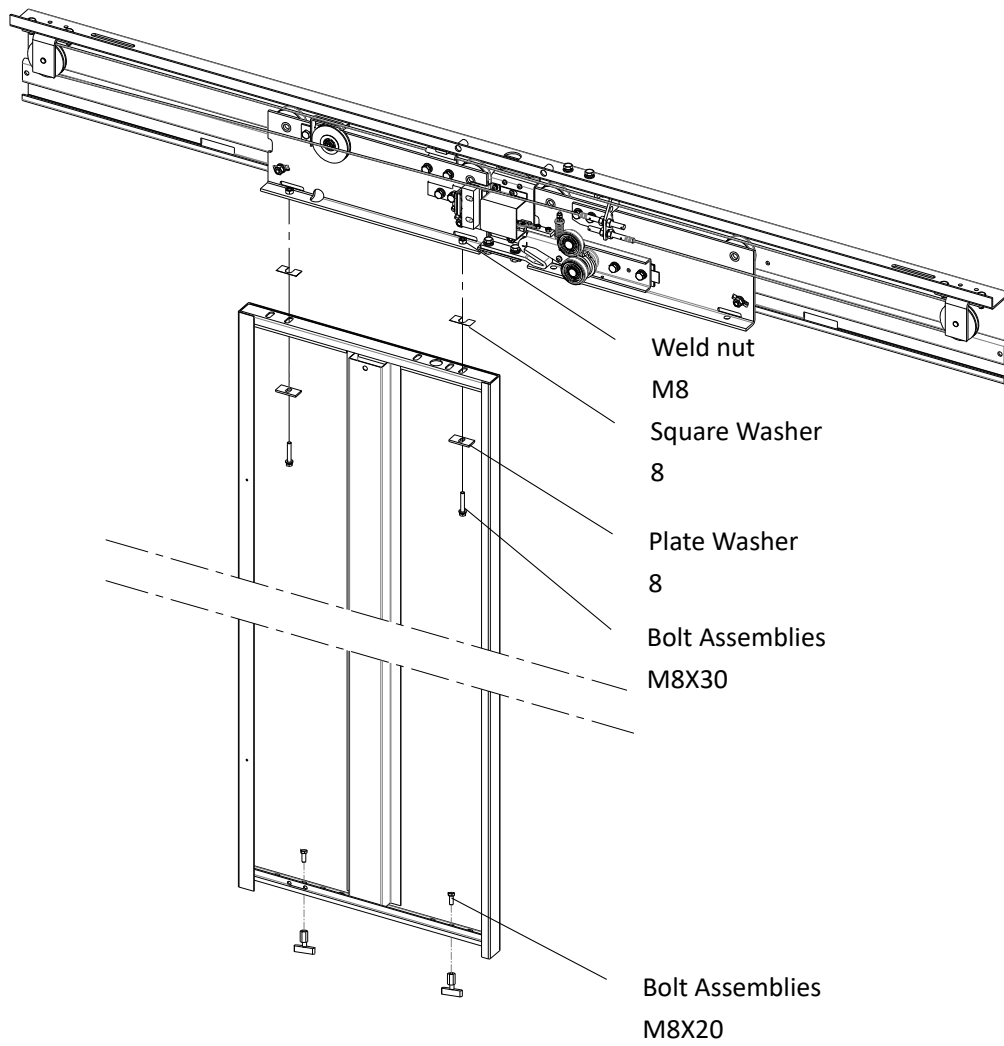

Figure 5-16(CLD)

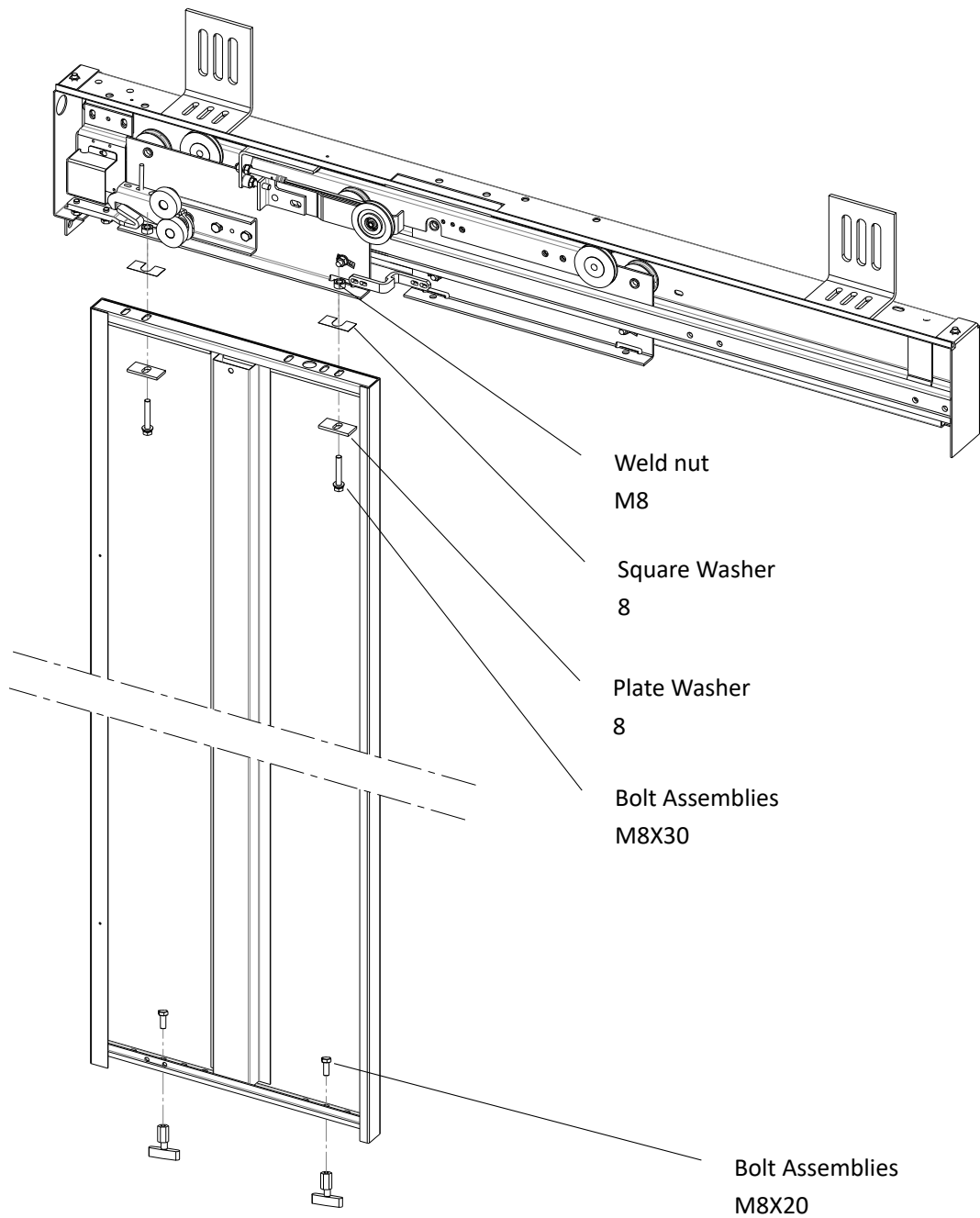

Figure 5-16(TLD)

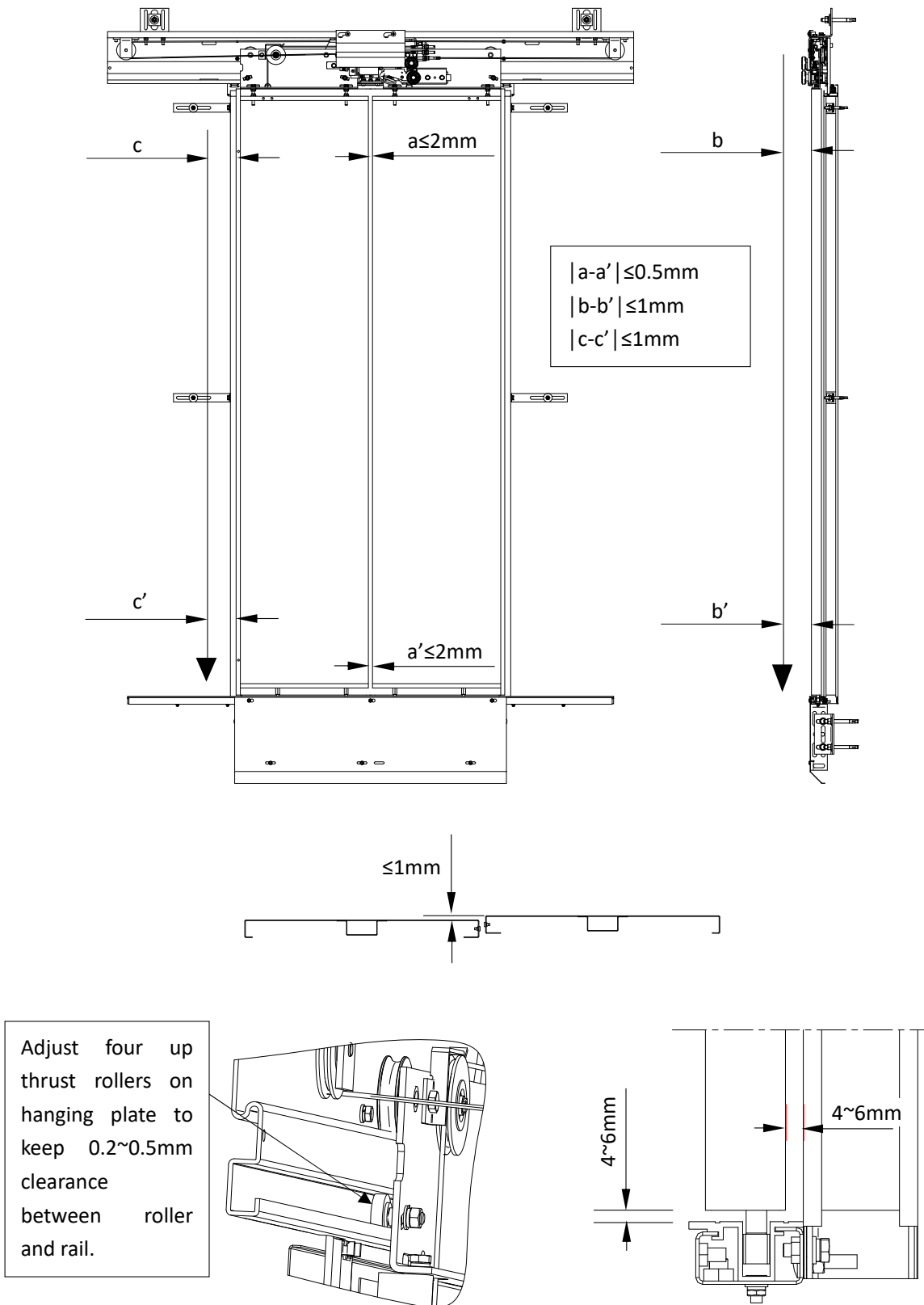

Figure 5-17(CLD)

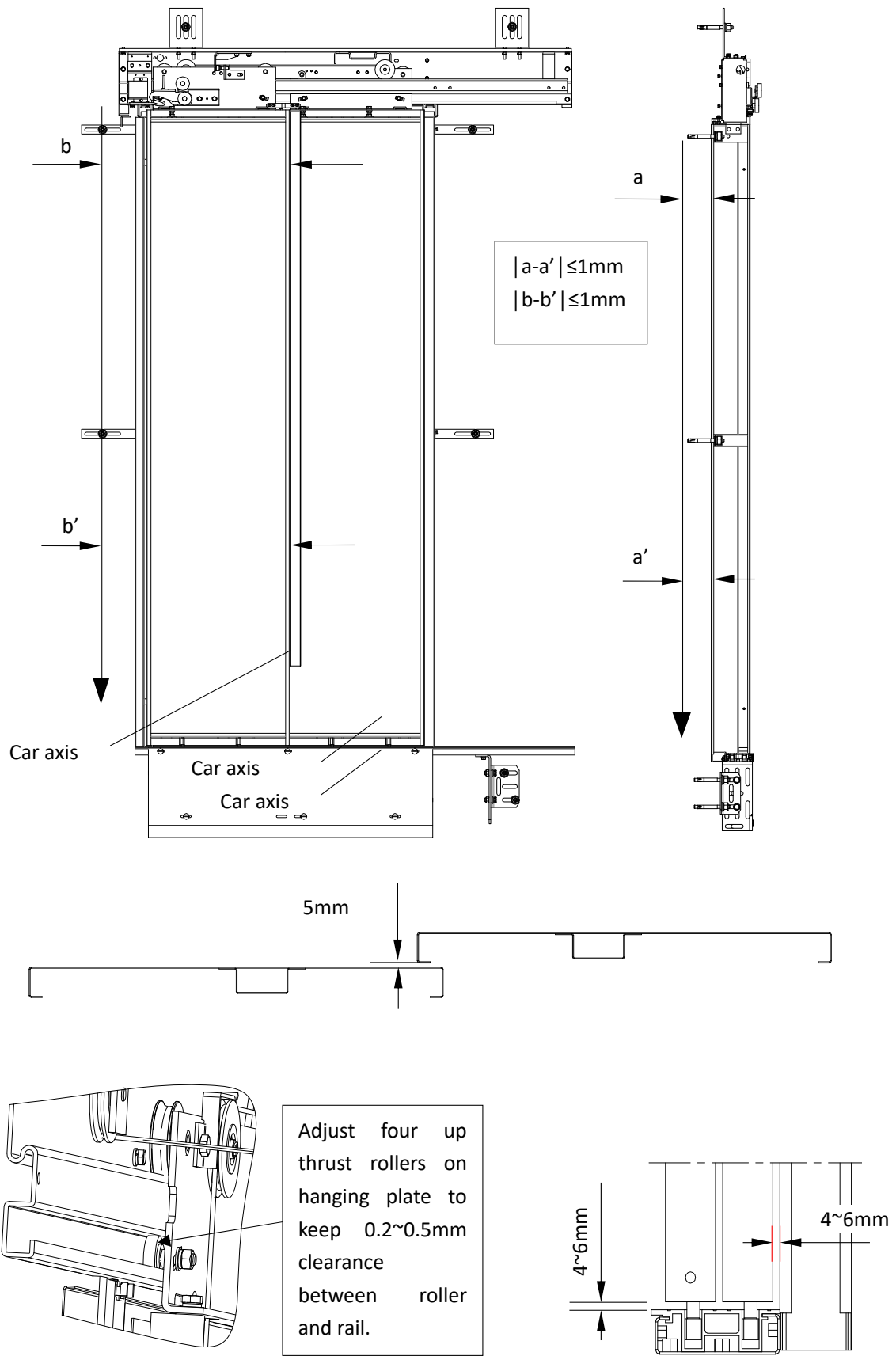

Figure 5-17(TLD)

### 5.5 Installation of door close weight

Step	Instruction	Fig
1	Connect the door close weight to the door header.	Figure 5-18
2	Connect the cover plate to the door header.	Figure 5-19

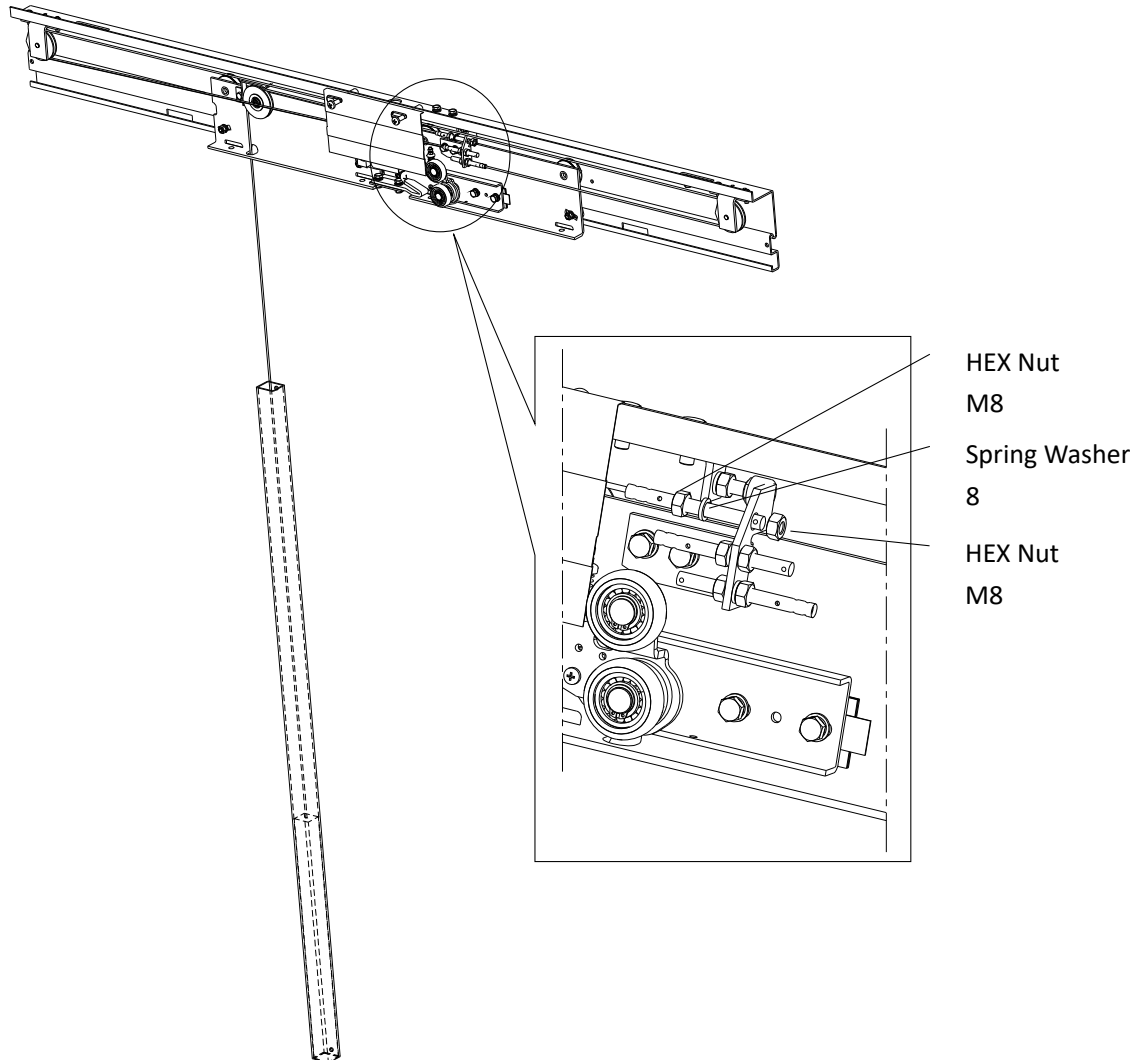

Figure 5-18 (CLD)

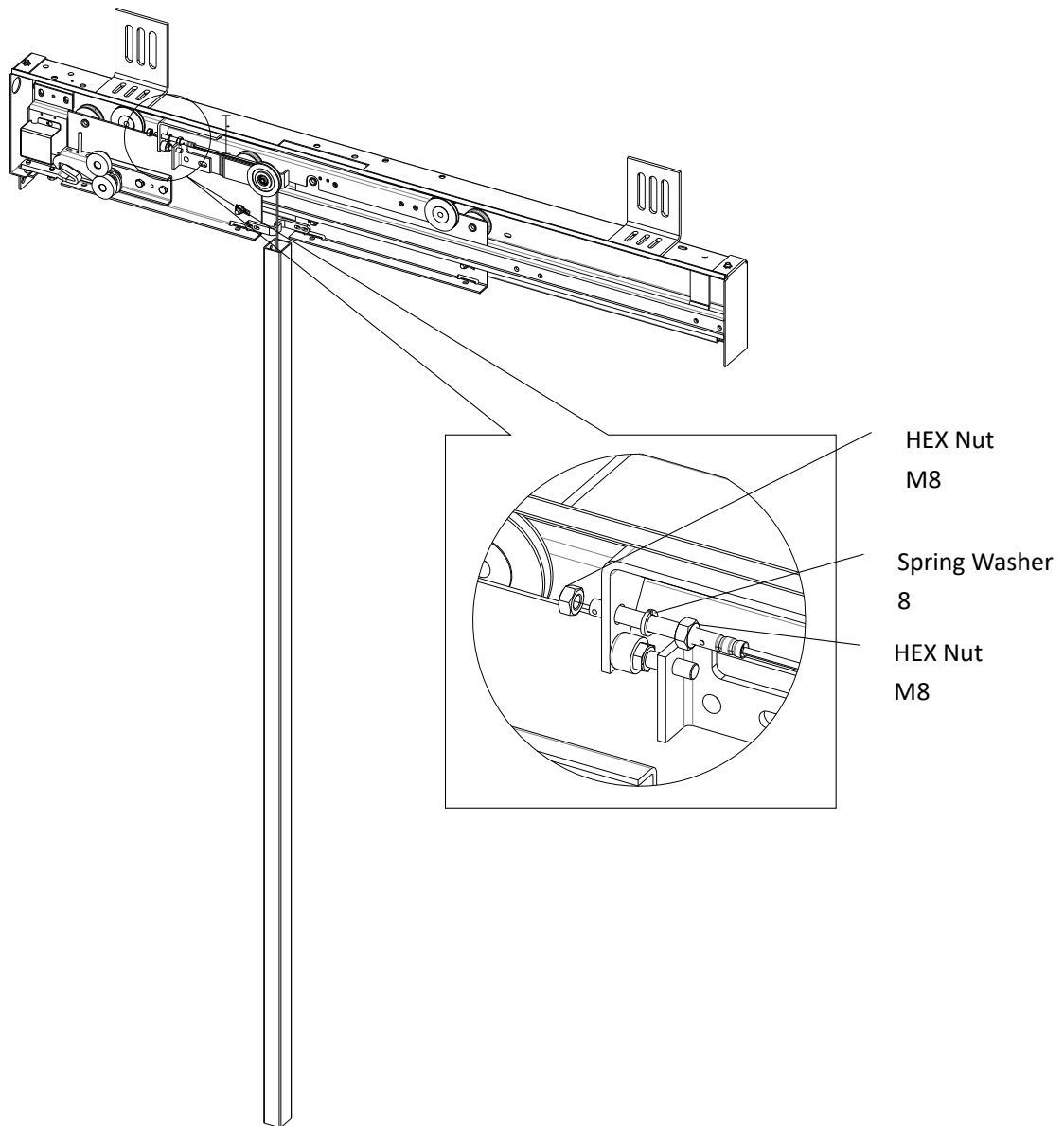

Figure 5-18 (TLD)



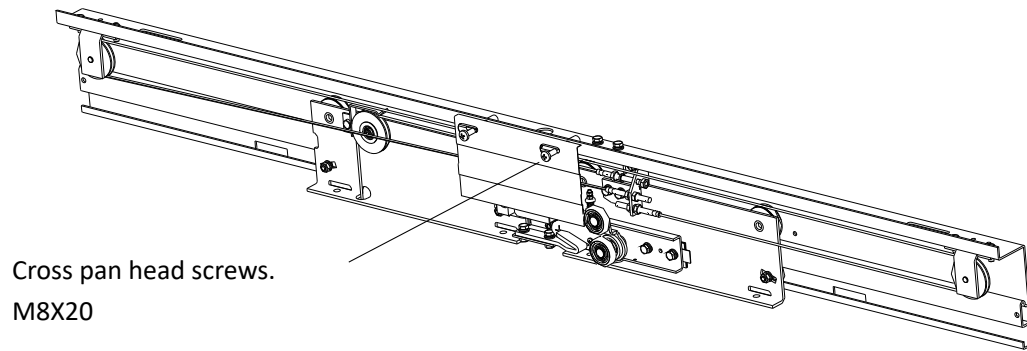

Figure 5-19

## 5.6 Adjust landing door lock

Step	Instruction	Fig
1	Adjust landing door lock clearance.	Figure 5-20

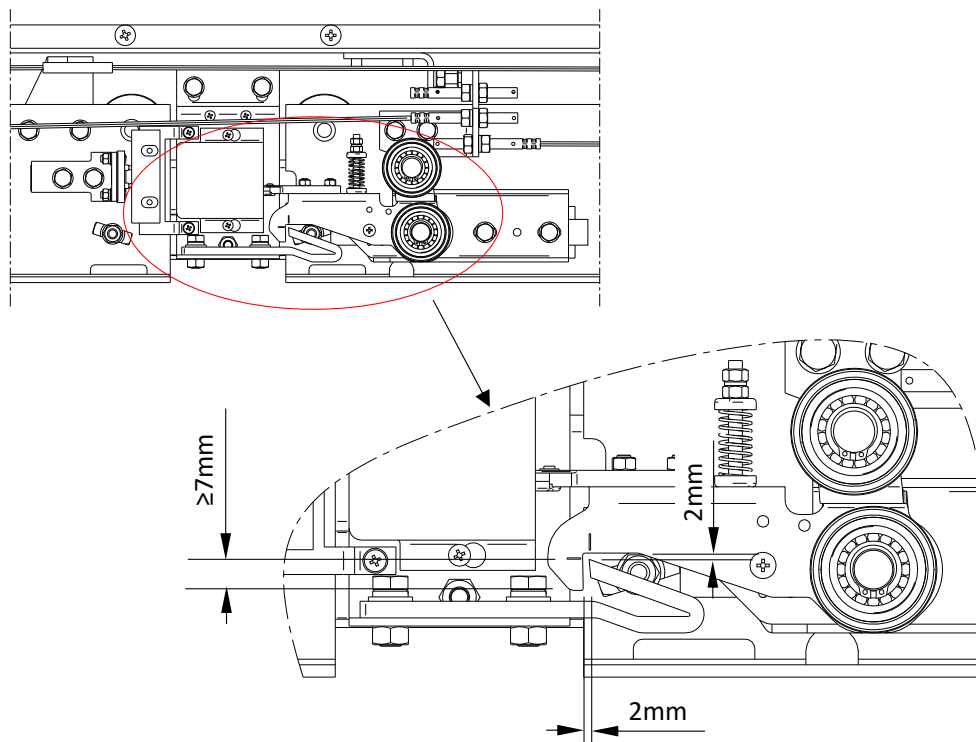

Figure 5-20

### Notice:

1. The mesh depth of lock hook and lock tongue should be not less than 7mm.
2. To keep 2mm clearance between lock hook and lock tongue.
3. Lock hook and lock tongue should be full mesh in level direction.
4. Active contact and still contact of door lock should be centered mesh; the compression of the contact should be not less than 3mm.
5. For center opening door, with 300N force to pull two door panels in opening direction, the distance between two panels should be not more than 30mm; the door lock contact should not break.
6. For side opening door, with 300N force to pull the main door panel in opening direction, the opening door dimension should be not more than 30mm; the door lock contact should not break.
7. The clearance between door lock roller and car sill should be within 5-10mm.
8. Landing door should be grounding.

## 6 Installation of machine

Machine installation overall picture:

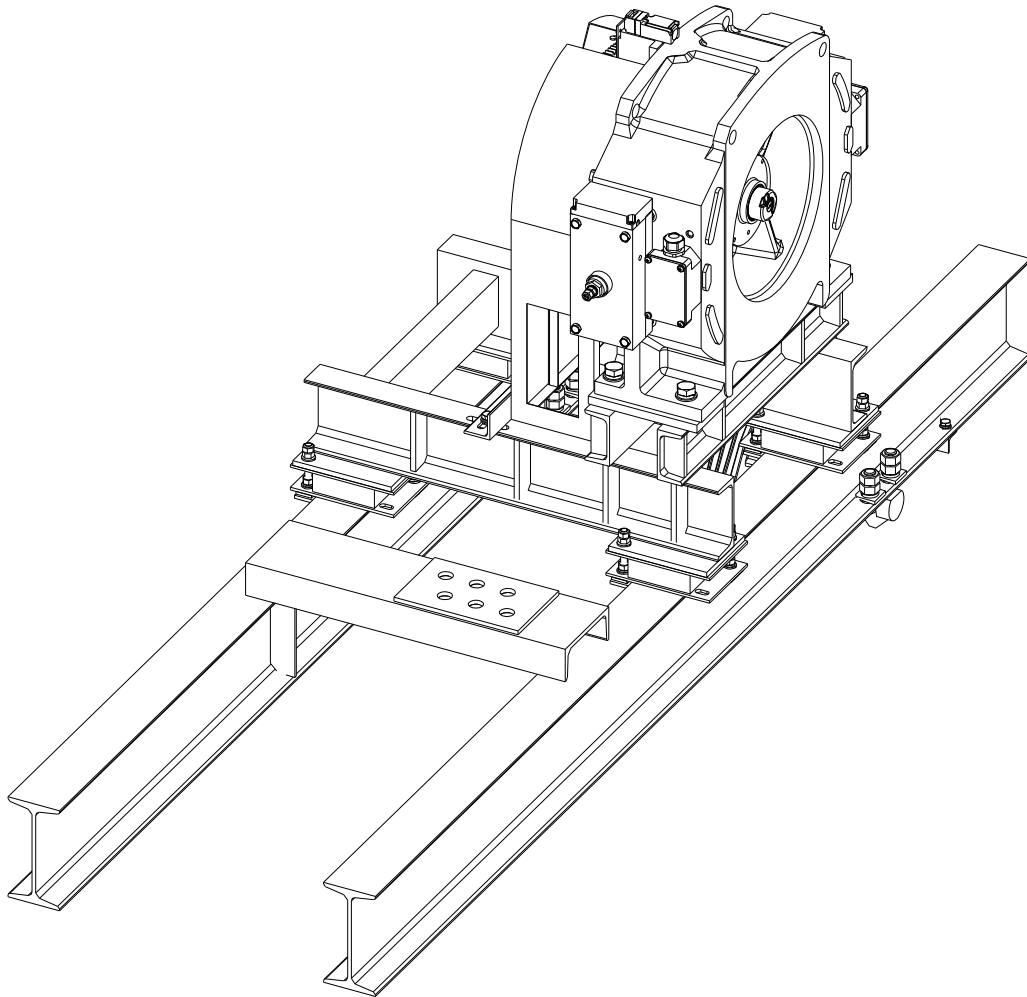

$DL \leq 1000\text{Kg}$  &  $V \leq 1.75\text{m/s}$

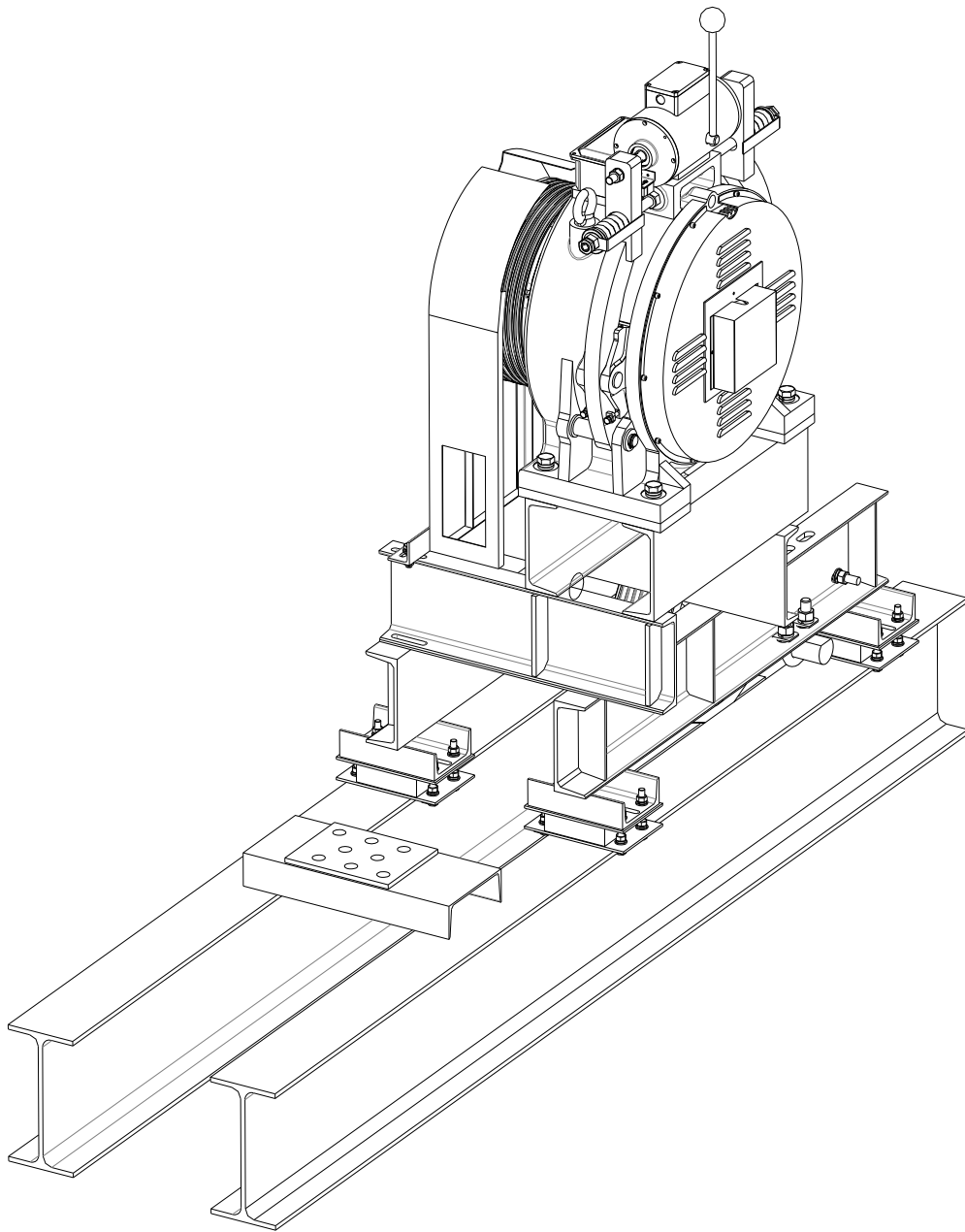

DL>1000Kg or V>1.75m/s

**6.1 Pre-installation preparations**

Step	Instruction	Fig
1	First clean the machine room, sweep out the soil and waste in the machine room, clean host and the host beams, in particular to clean their contact surfaces.	N/A
2	Through the preformed hole in machine room, extend the car axis and the counterweight axis to the machine room by the plumb, and use these points to draw line. The distance of beam center line refers to layout.	Figure 6-1

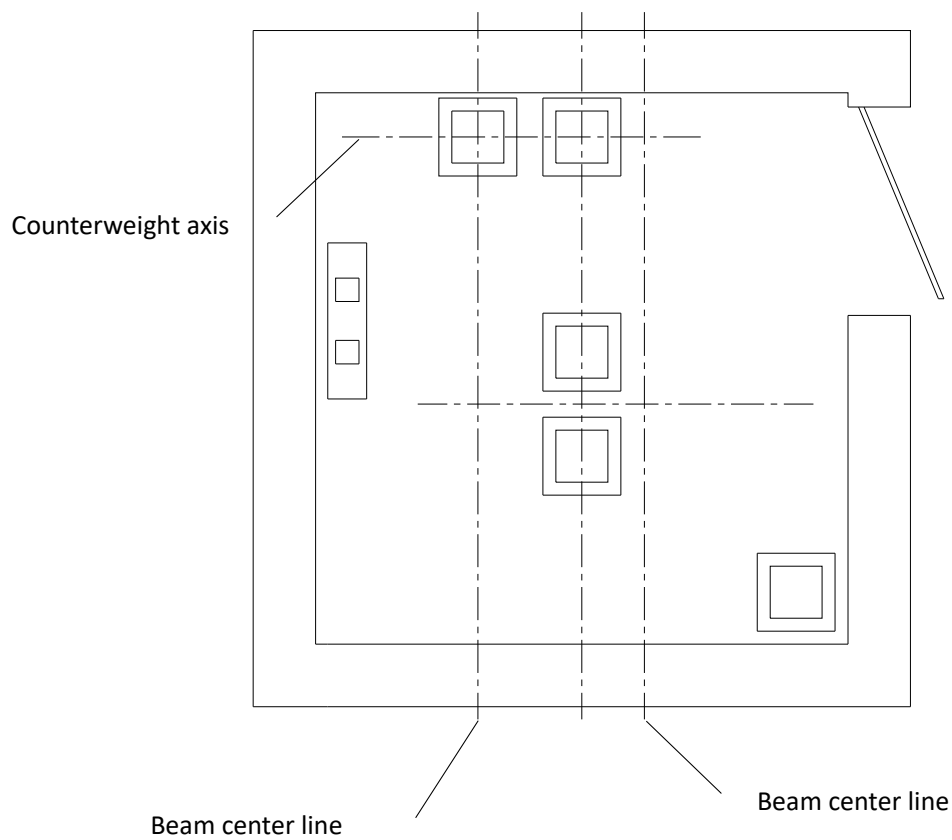

Figure 6-1

## 6.2 Installation of machine beam

Step	Instruction	Fig
1	Put the beam on the bearing plate and adjust it refer to the layout. After adjustment, fix them onto the bearing plate by welding.	Figure 6-2(1) Figure 6-2(2)
2	Make a foundation with concrete at two ends.	N/A

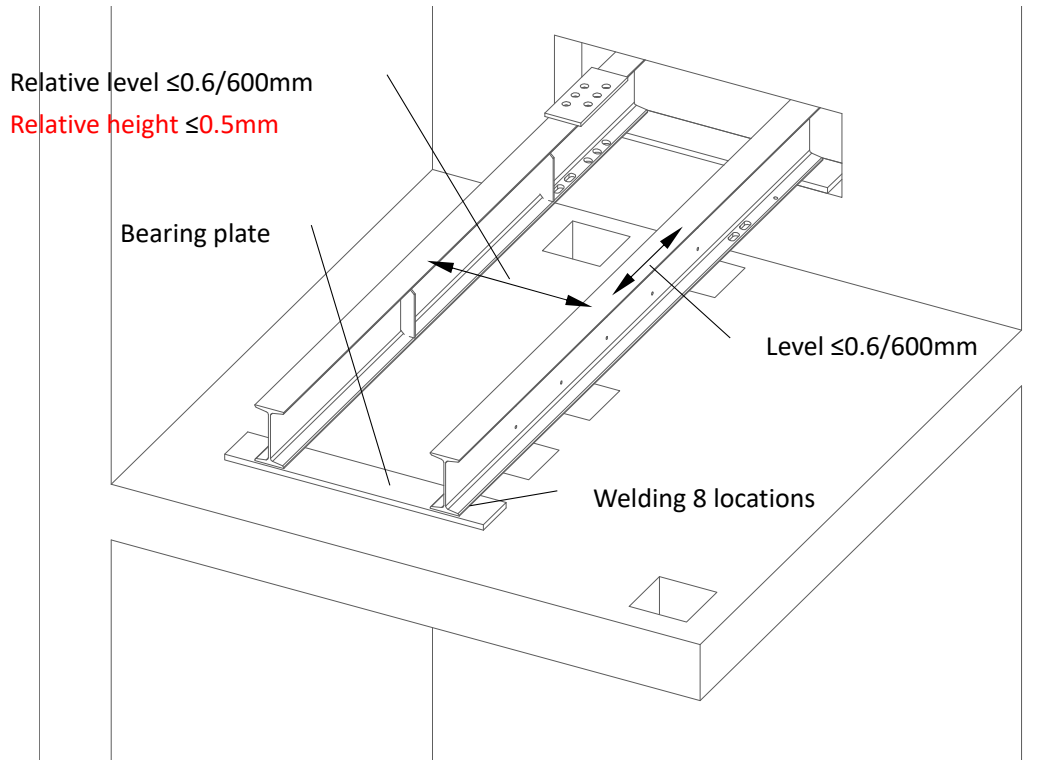
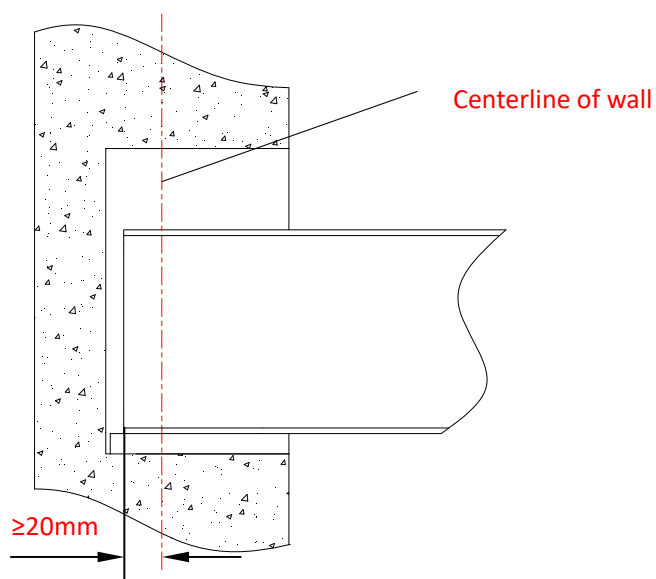

Figure 6-2(1)

$DL \leq 1000\text{Kg}$  &  $V \leq 1.75\text{m/s}$



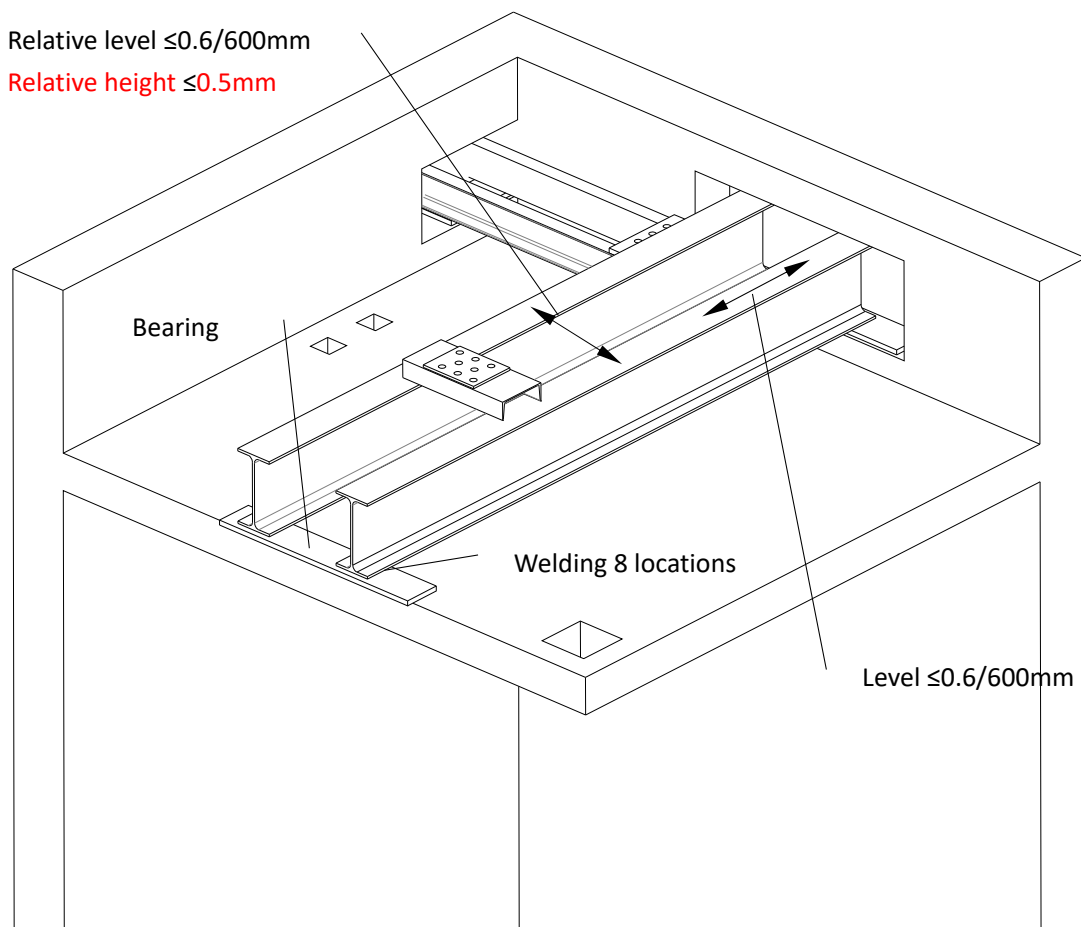
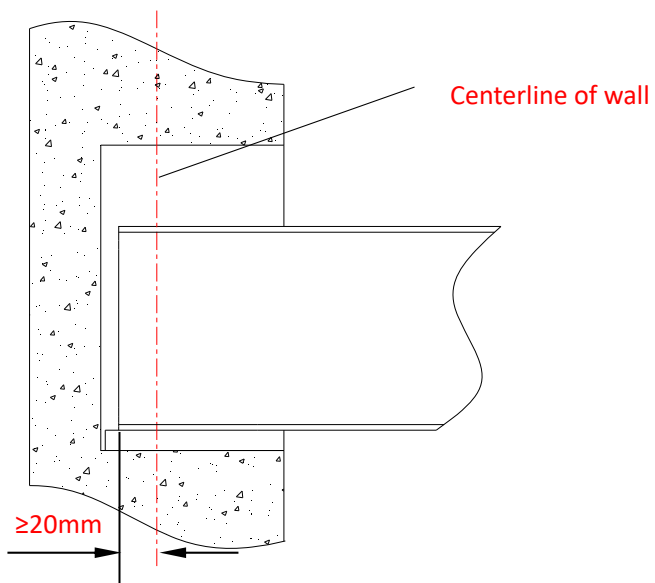

Figure 6-2(2)  
DL>1000Kg or V>1.75m/s



### 6.3 Installation of machine

#### 6.3.1 $DL \leq 1000\text{Kg}$ & $V \leq 1.75\text{m/s}$

Step	Instruction	Fig
1	Put the rubbers and dead end hitch plates on the beam.	Figure 6-3(1)
2	Connect the bedplate to the rubbers.	Figure 6-4(1), 6-5(1)
3	Connect the machine to the bedplate.	Figure 6-6(1)
4	Connect the deflection sheaves on the beam.	Figure 6-7(1)
5	Connect the rope retainer on the beam.	Figure 6-8(1)
6	Connect the machine guard shield on the bedplate.	Figure 6-9(1)
7	Adjust the traction sheave and guide sheave.	Figure 6-10(1)

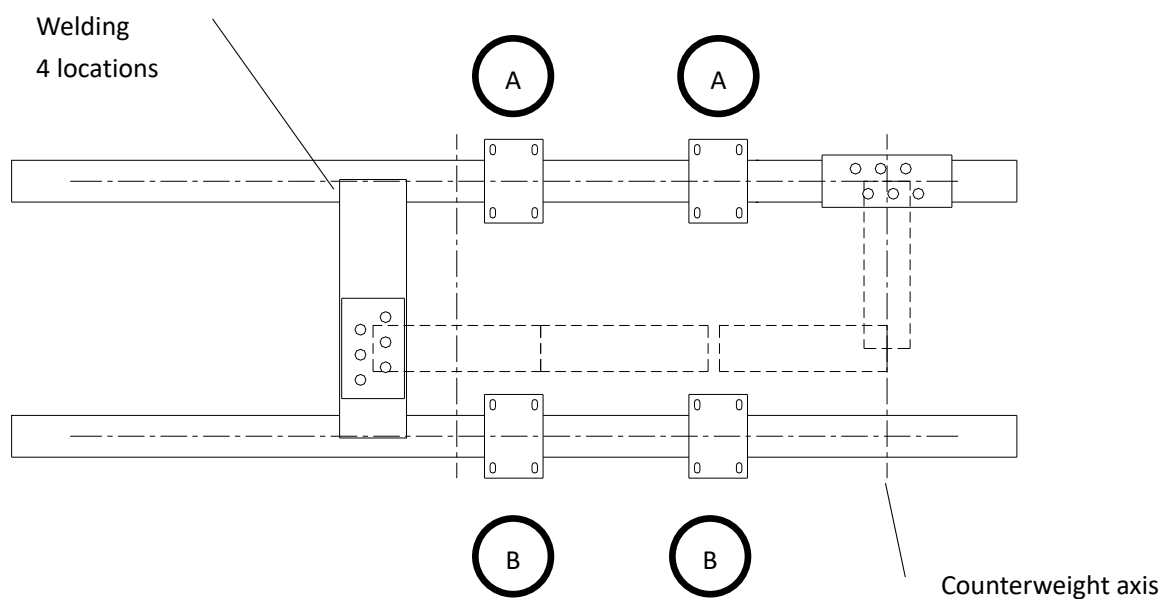

PART	A	B
SDA199B--	1	2

Figure 6-3(1)

**Note: The bigger number rubber is harder, it should be placed on the beam that is near the traction sheave and endures the bigger tension.**

The deviation between rope center of the plate and corresponding rope center like the following

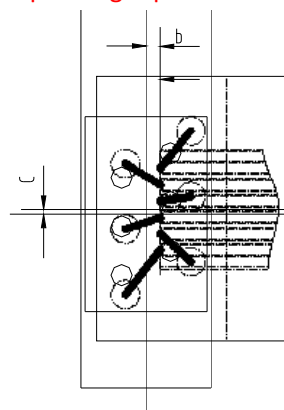

figure shown b and c is not more than 2mm



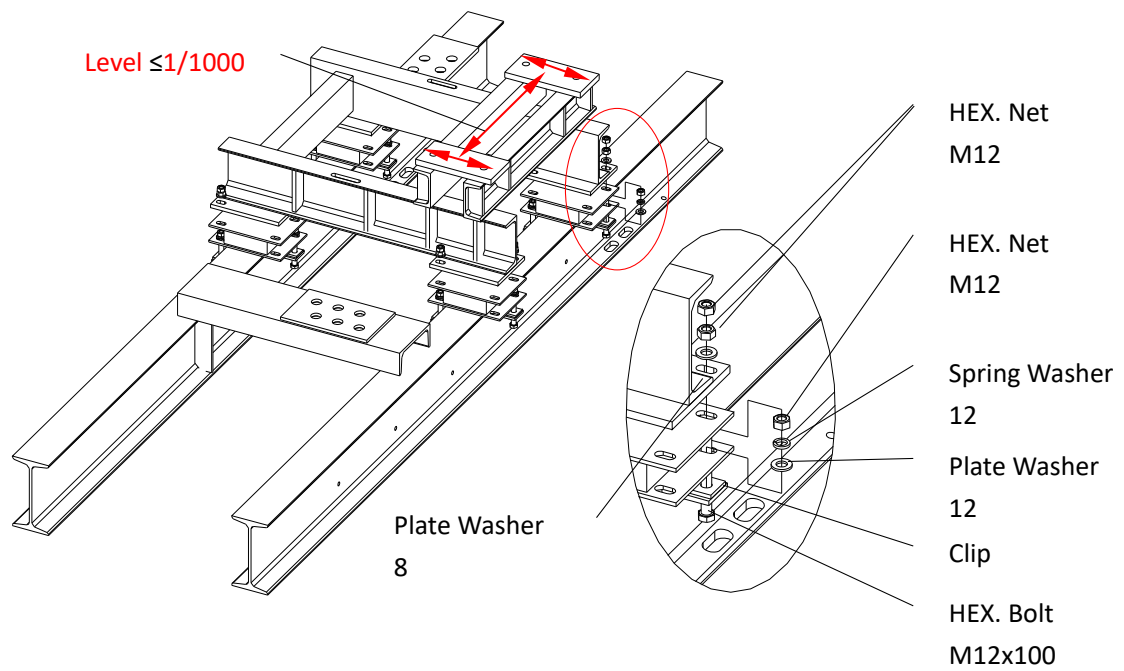

Figure 6-4(1)

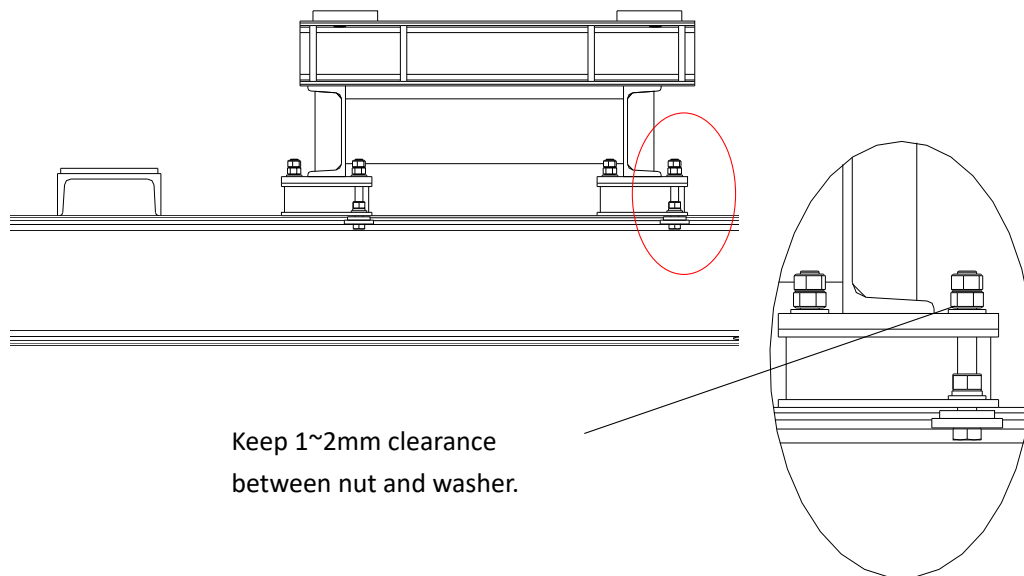

Figure 6-5(1)

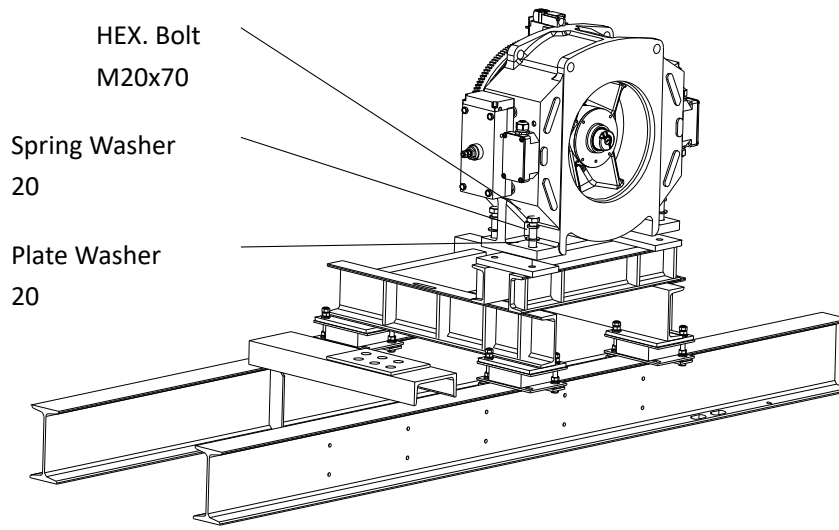

Figure 6-6(1)

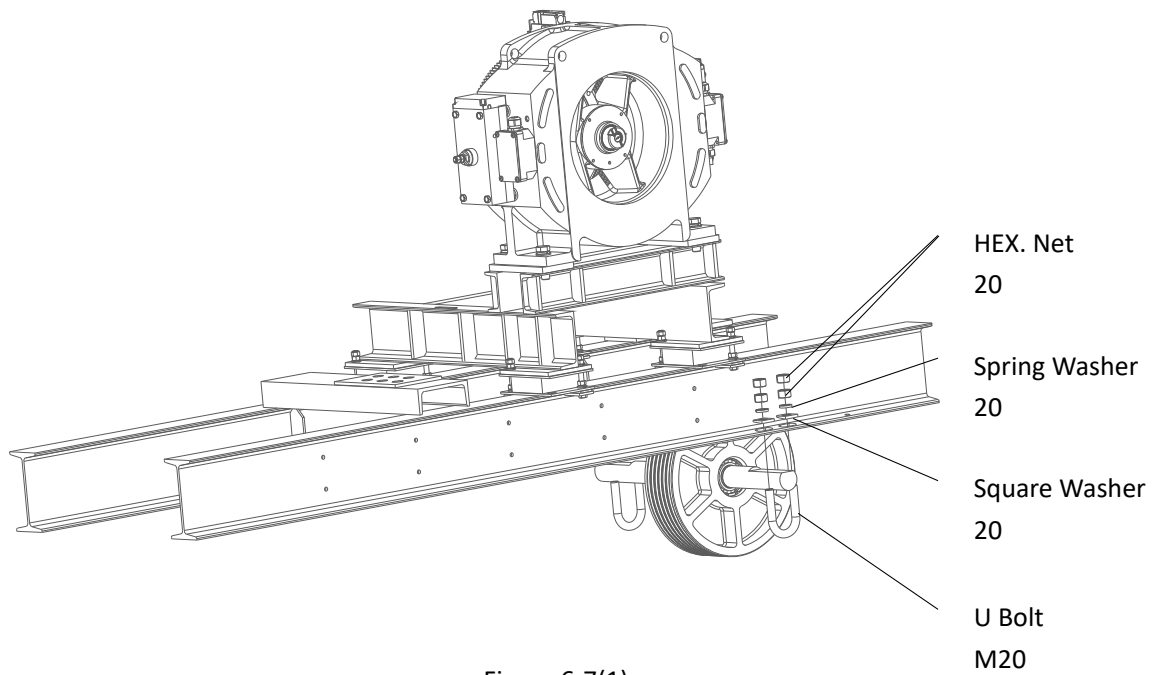
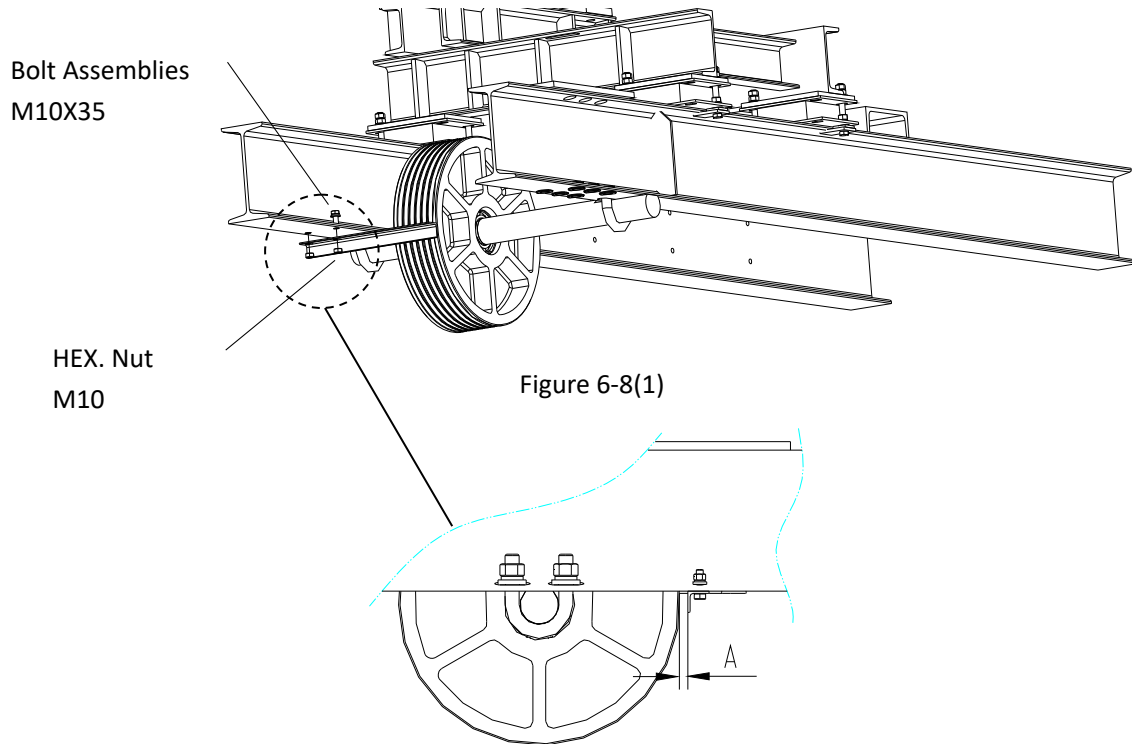

Figure 6-7(1)



Rope diameter d	Φ8	Φ10	Φ12	Φ13
The gap between rope retainer and rope A	1~2mm	2~3mm	2~3mm	2~4mm

This table applies to the traction sheave and the guide sheave

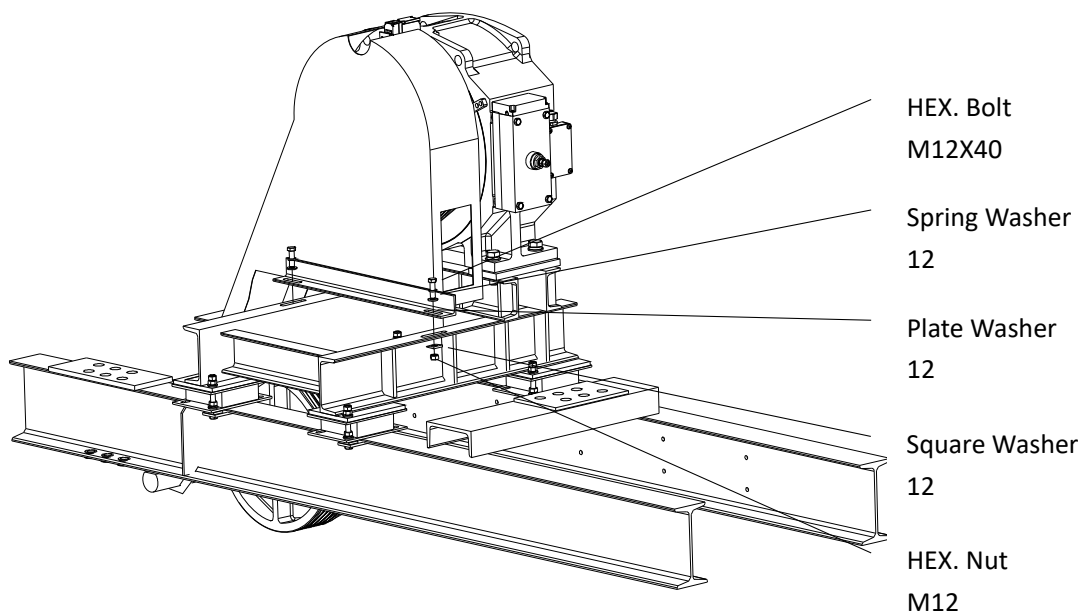

Figure 6-9(1)

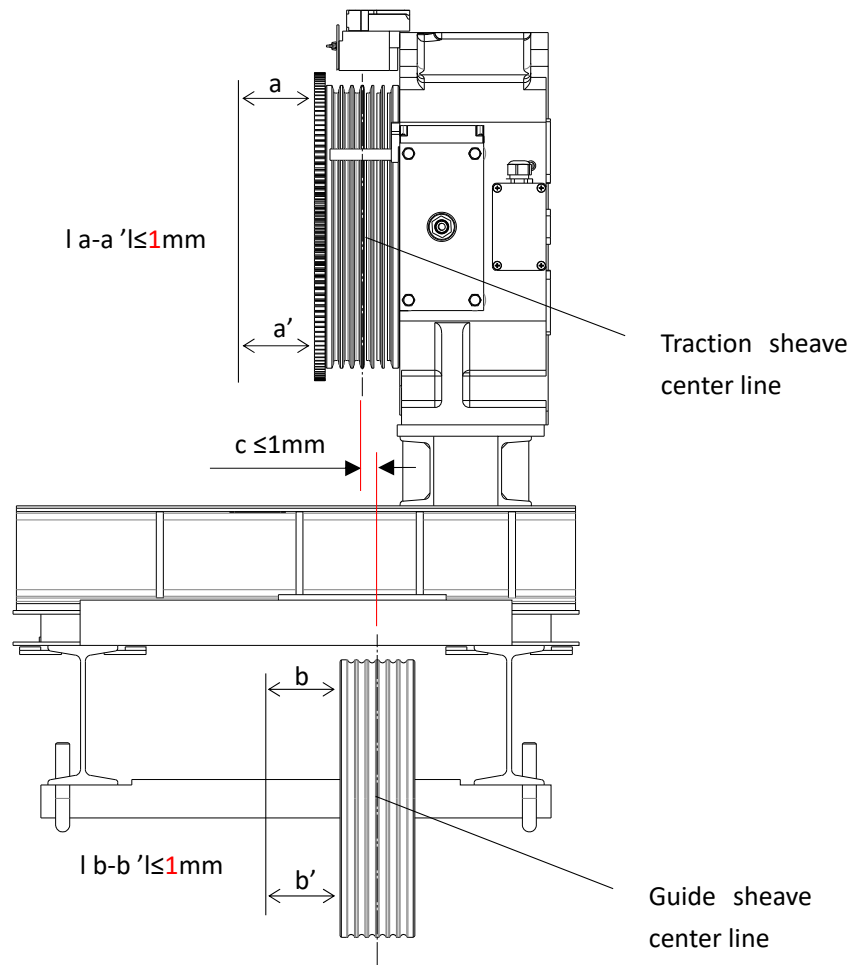

Figure 6-10(1)

**6.3.2 DL>1000Kg or V>1.75m/s**

Step	Instruction	Fig
1	Put the rubbers and dead end hitch plates on the beam.	Figure 6-3(2)
2	Connect the bedplate to the rubbers.	Figure 6-4(2), 6-5(2)
3	Connect the machine to the bedplate.	Figure 6-6(2)
4	Connect the deflection sheaves on the machine bed.	Figure 6-7(2)
5	Connect the rope retainer on the beam.	Figure 6-8(2)
6	Connect the machine guard shield on the bedplate.	Figure 6-9(2)
7	Adjust the traction sheave and guide sheave.	Figure 6-10(2)

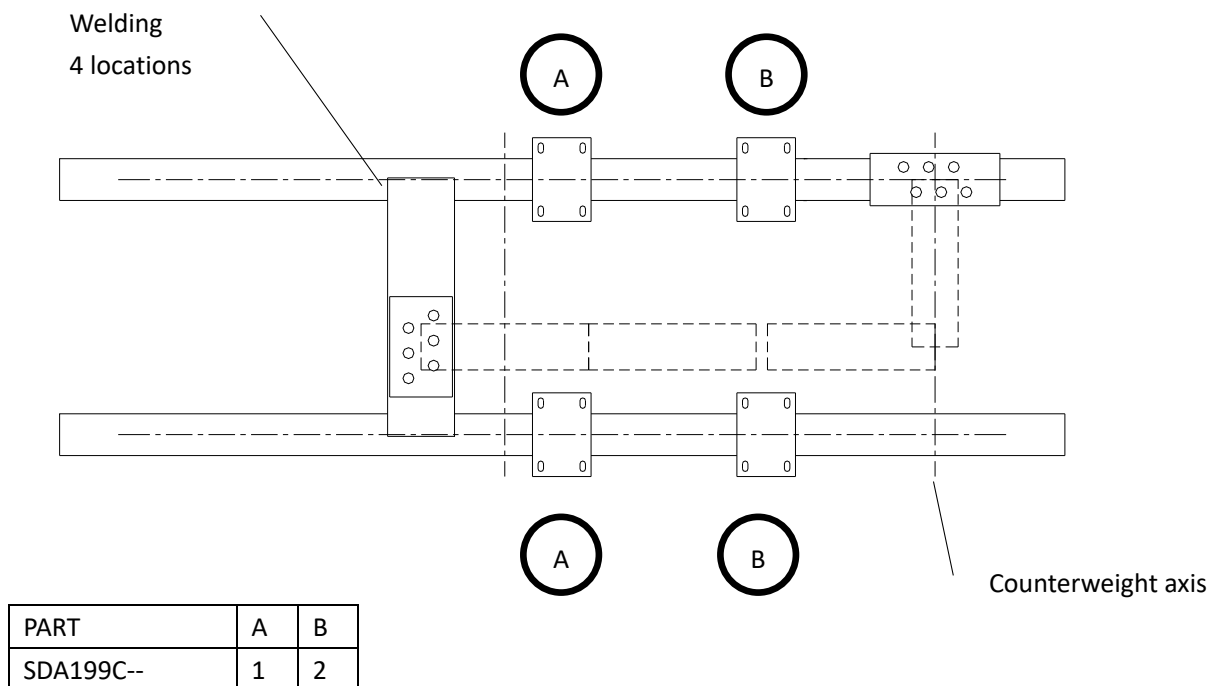

Figure 6-3(2)

**Note: The bigger number rubber is harder, it should be placed on the beam that is near the traction sheave and endures the bigger tension.**

The deviation between rope center of the plate and corresponding rope center like the following

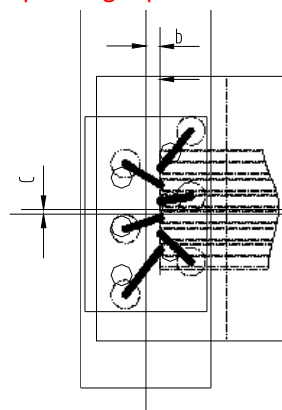

figure shown b and c is not more than 2mm

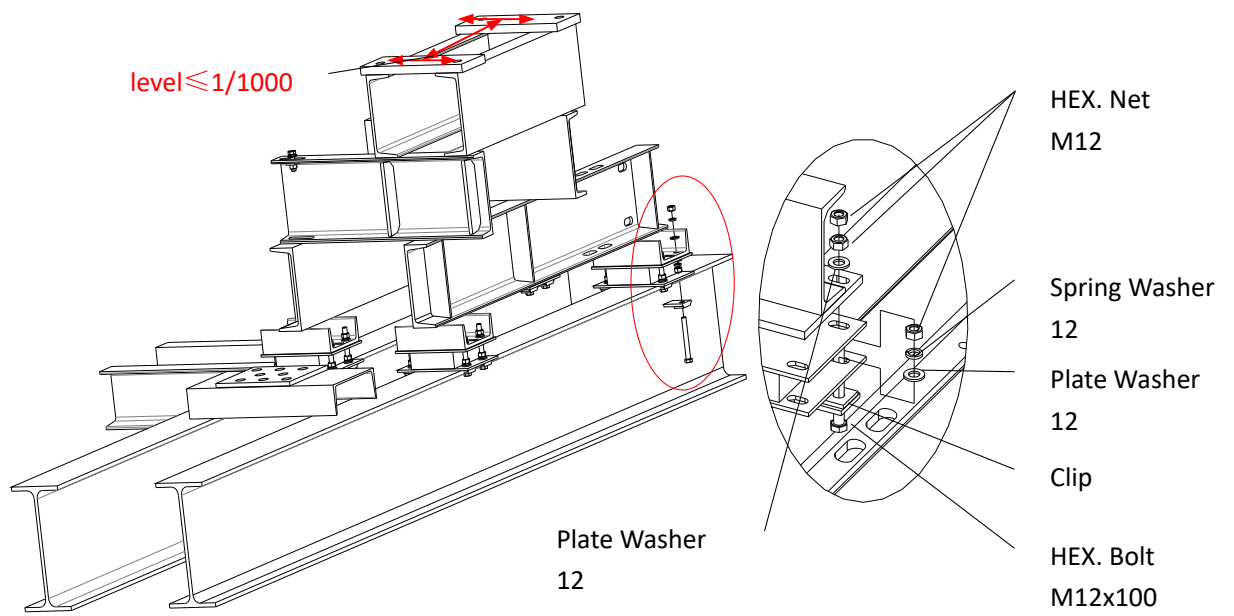

Figure 6-4(2)

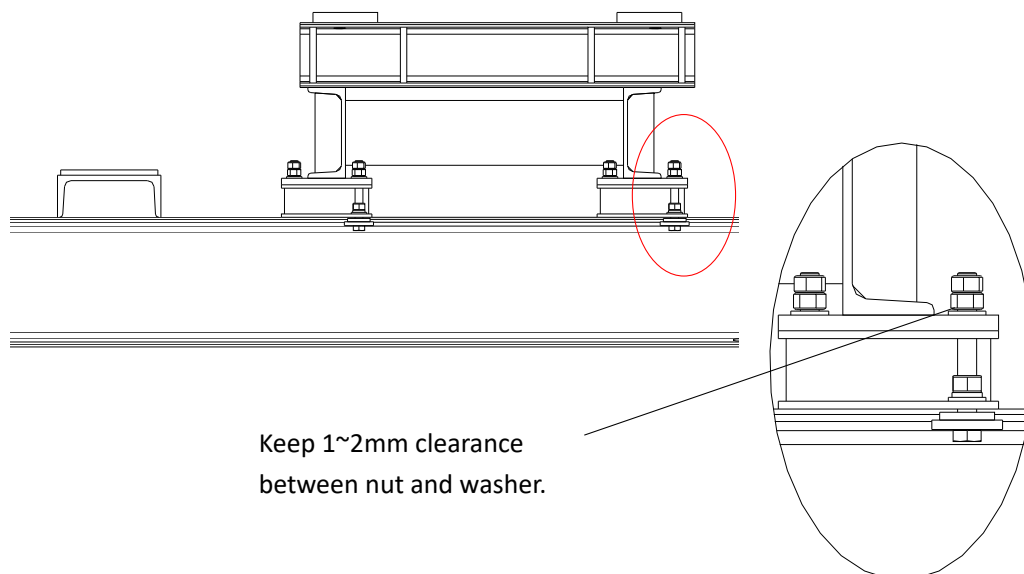

Figure 6-5(2)

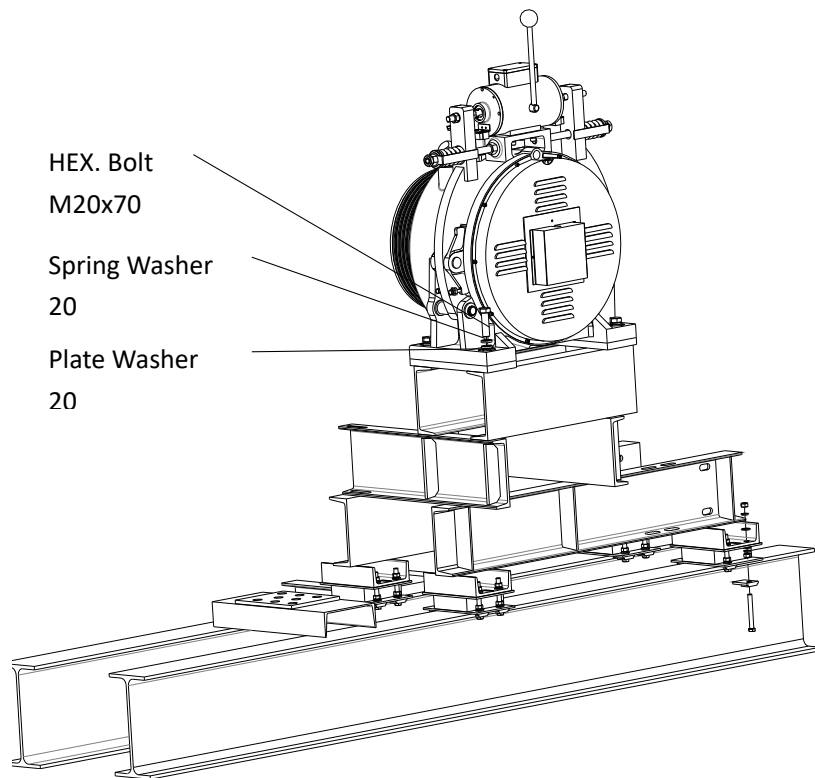

Figure 6-6(2)

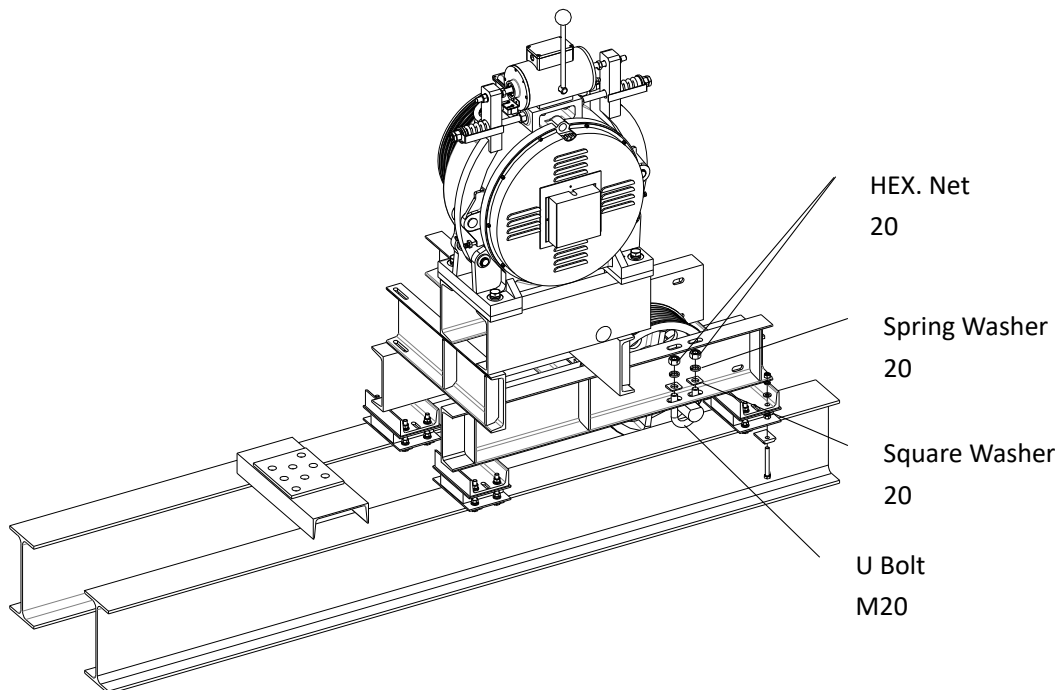

Figure 6-7(2)

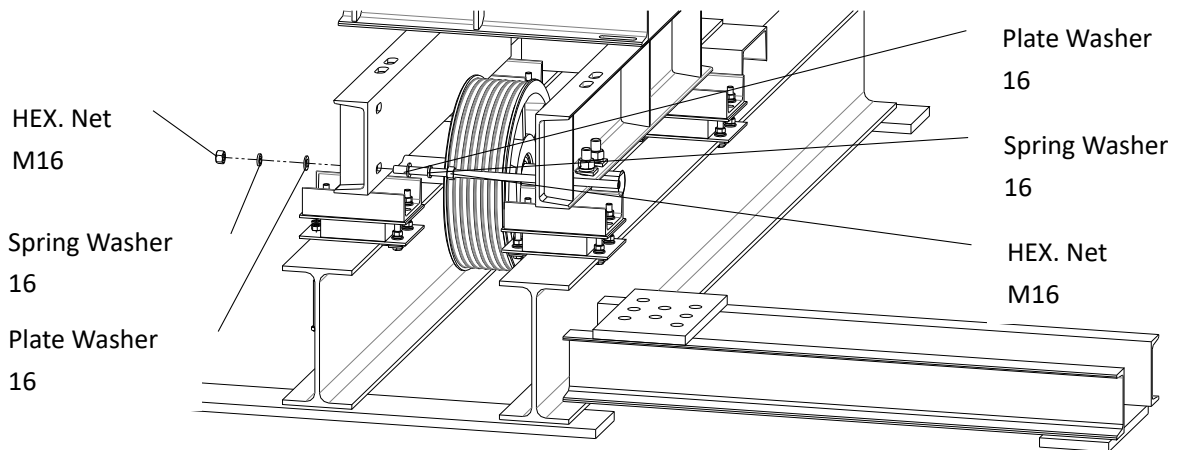

Figure 6-8(2)

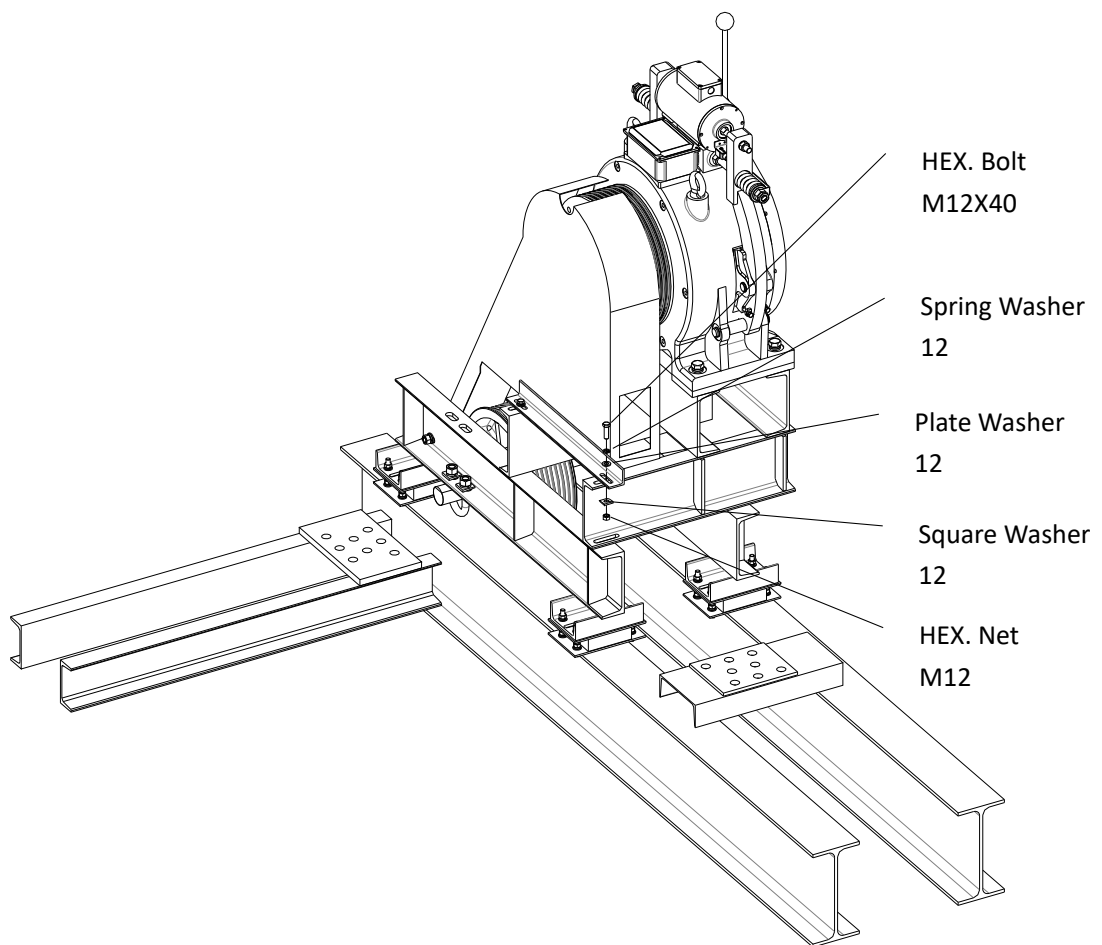

Figure 6-9(2)



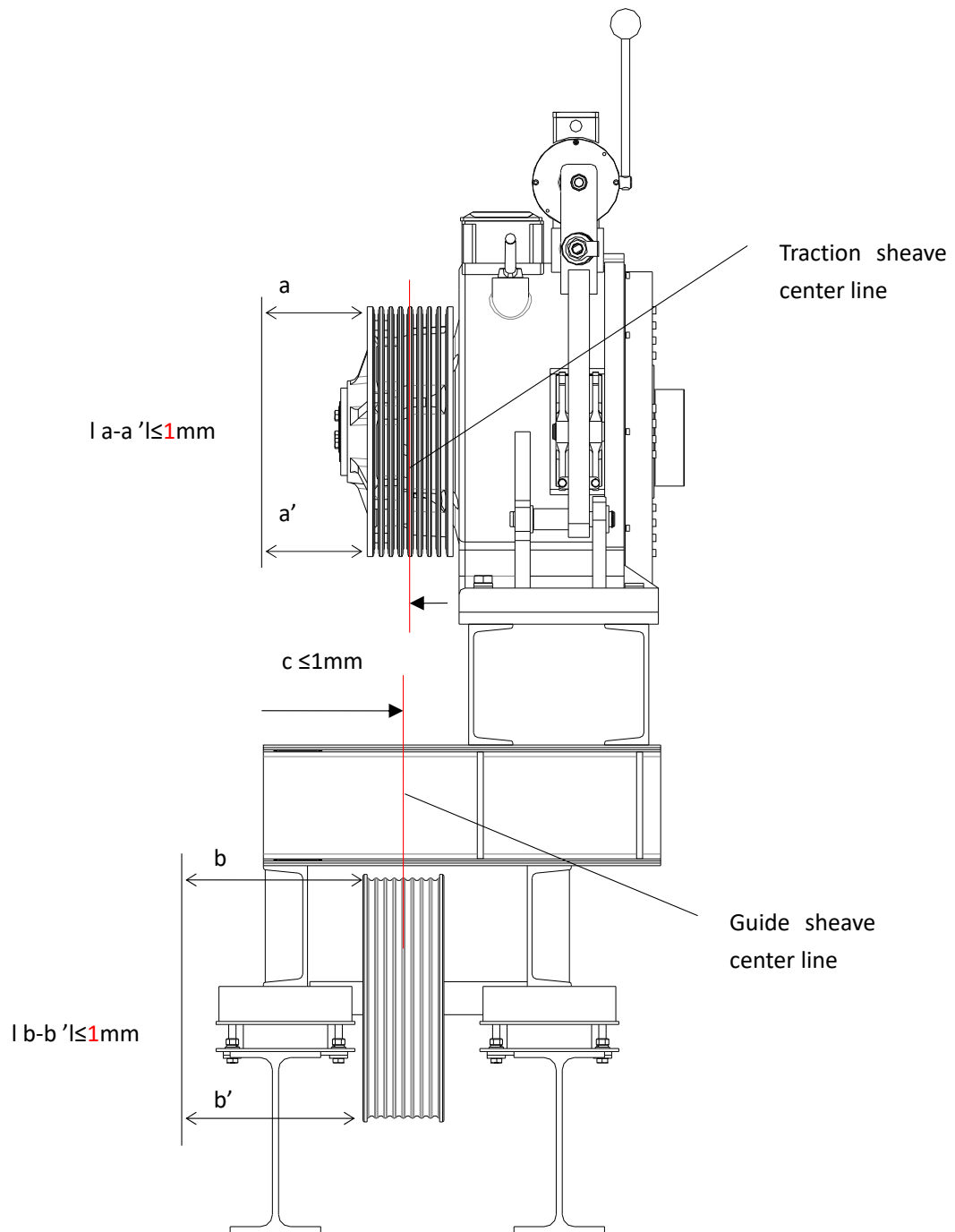
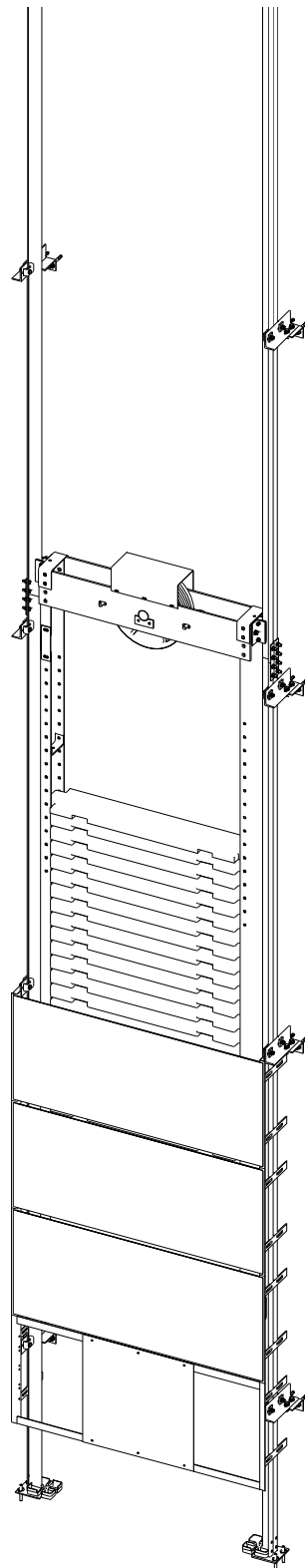

Figure 6-10(2)

## 7 Installation of counterweight

Counterweight installation overview:



### 7.1 Installation of counterweight frame

Step	Instruction	Fig
1	Connect the counterweight base under the frame.	Figure 7-1
2	Place the CWT frame on the upper part.	Figure 7-2

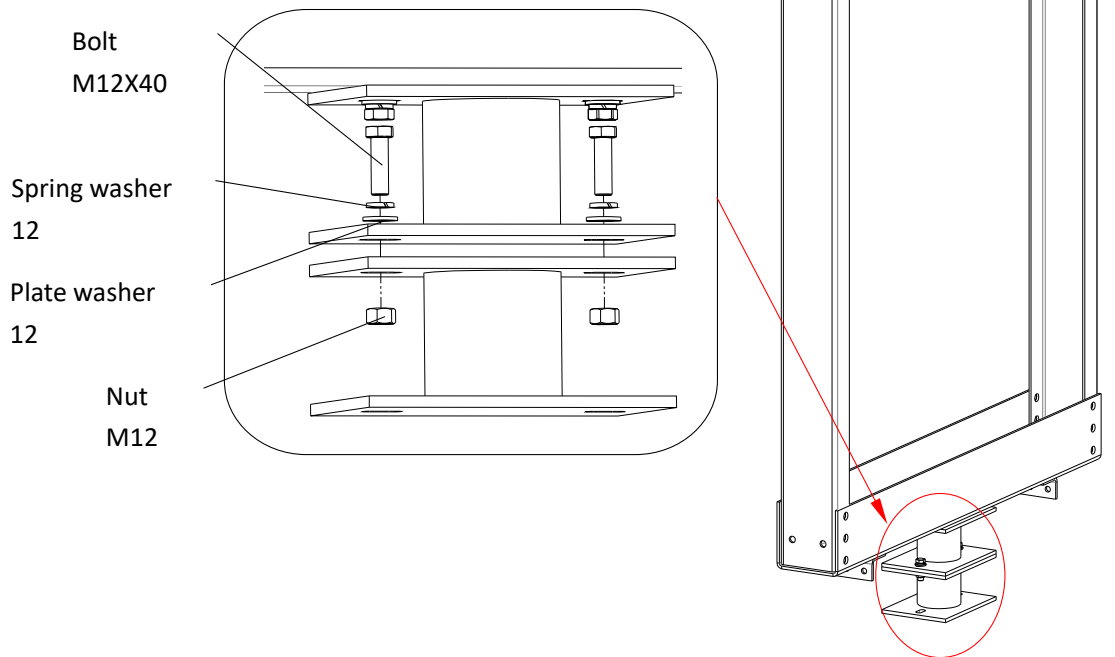

Figure 7-1

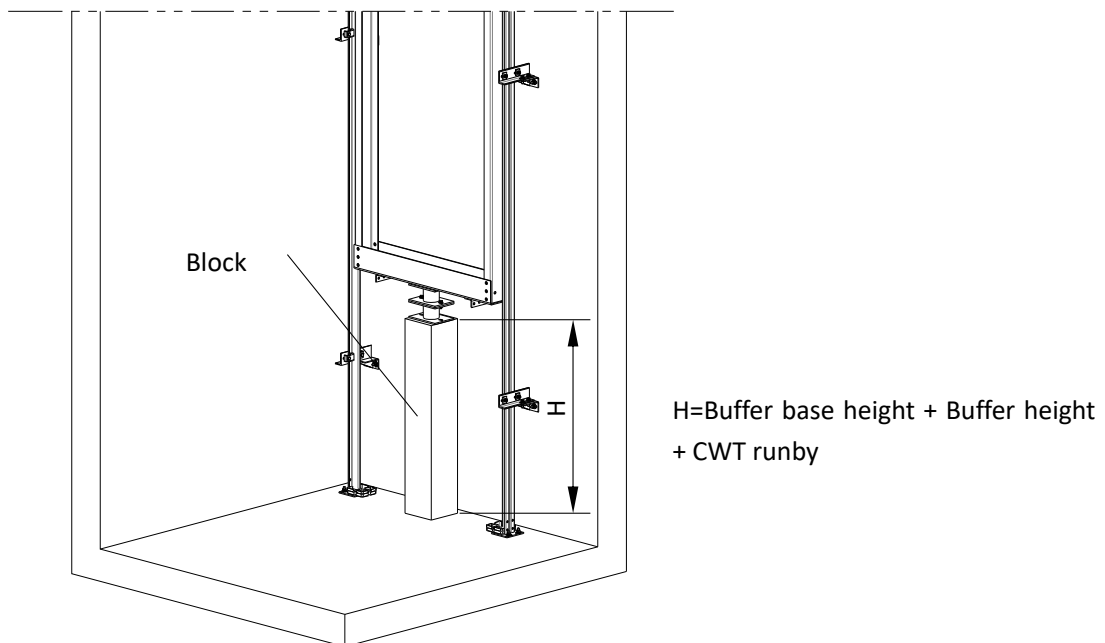

Figure 7-2

## 7.2 Installation of counterweight accessories

Step	Instruction	Fig
1	Install the guide shoes on the side of counterweight frame.	Figure 7-3
2	Add counterweight filler into the counterweight frame.	Figure 7-4
3	Install the counterweight filler pressing plates.	Figure 7-5
4	Install the oil bottle on the counterweight.	Figure 7-6

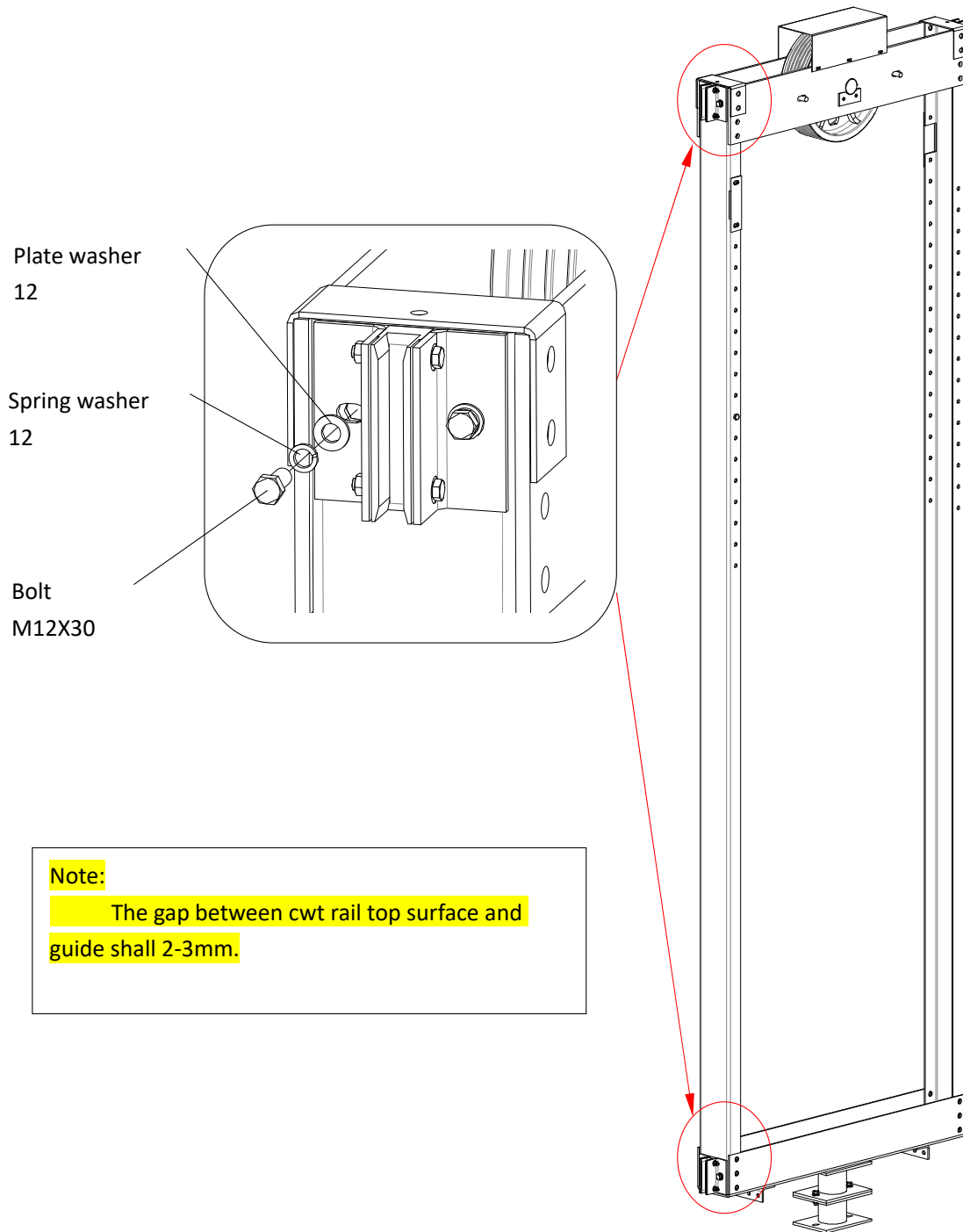

Figure 7-3

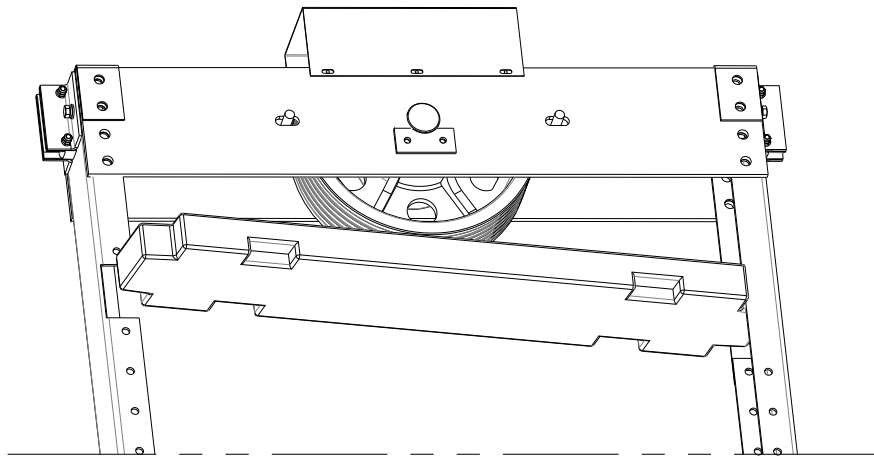

Figure 7-4

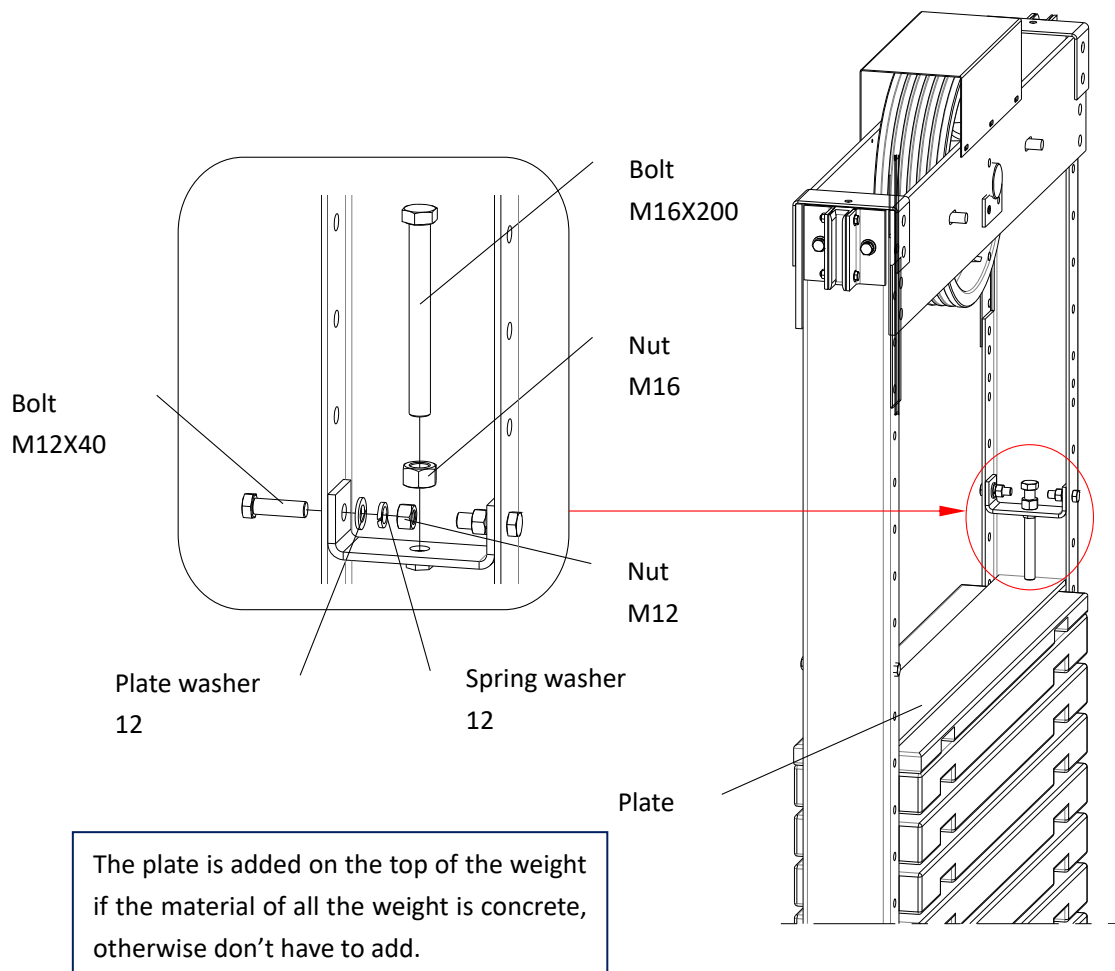

Figure 7-5

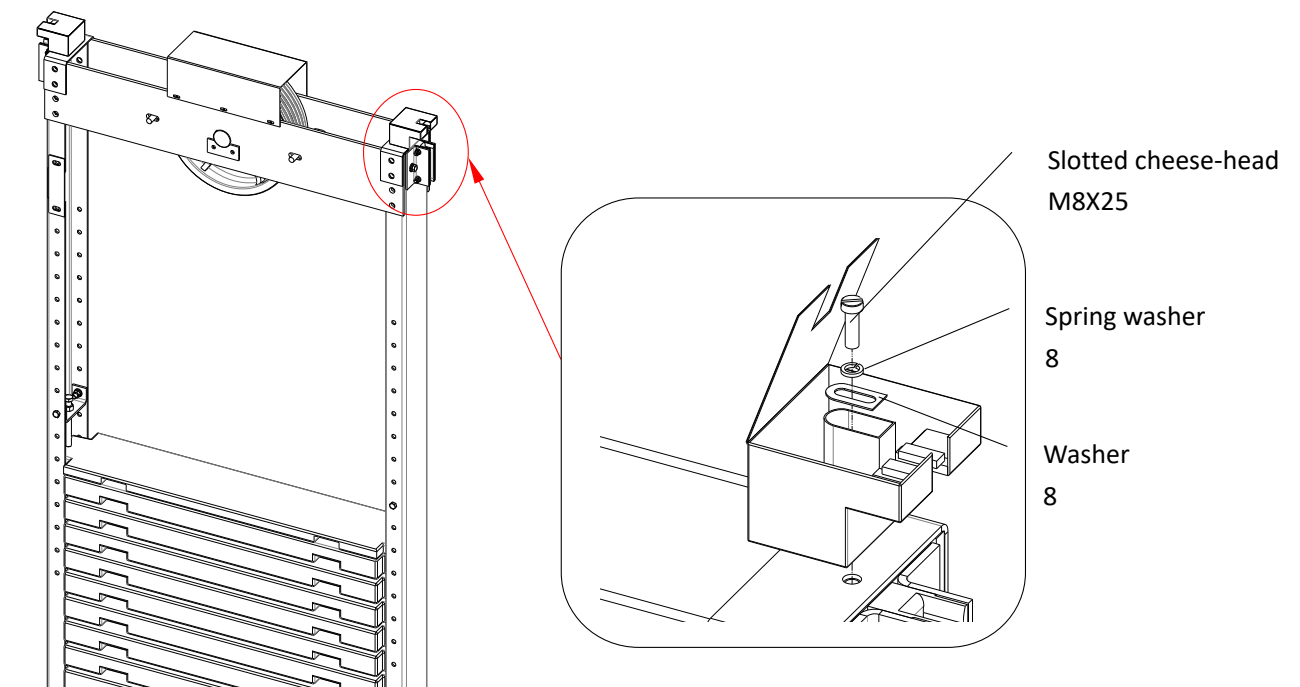

Figure 7-6

A value shown in table7-1

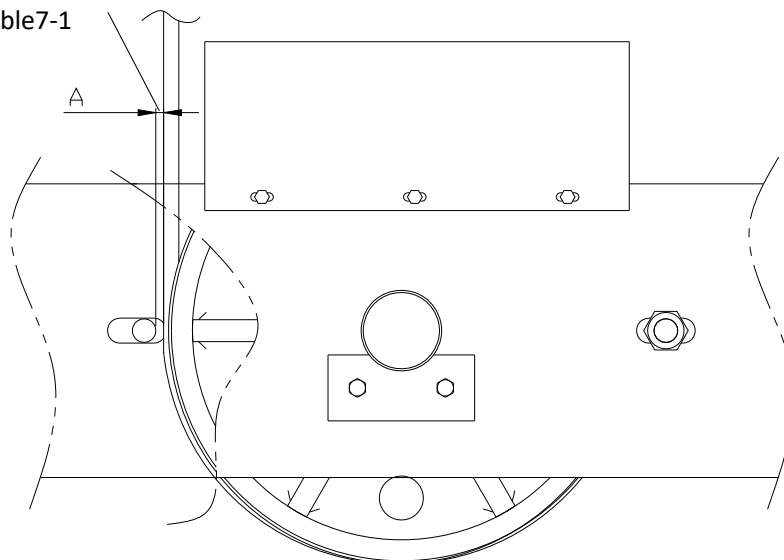

Figure 7-7

Rope diameter d	Φ8	Φ10	Φ12	Φ13
The gap between rope and rope lever block A	1~2mm	2~3mm	2~3mm	2~4mm

This table applies sheave and the guide wheel

Table 7-1

### 7.3 Installation of counterweight screen

Step	Instruction	Fig
1	When the elevator need to install the compensation chain, the bottom of counterweight screen need to Affixed to the pit floor	Figure 7-7
2	Connect the support on the frame of counterweight screen.	Figure 7-8
3	Connect the counterweight screen net on the guide rail.	Figure 7-9

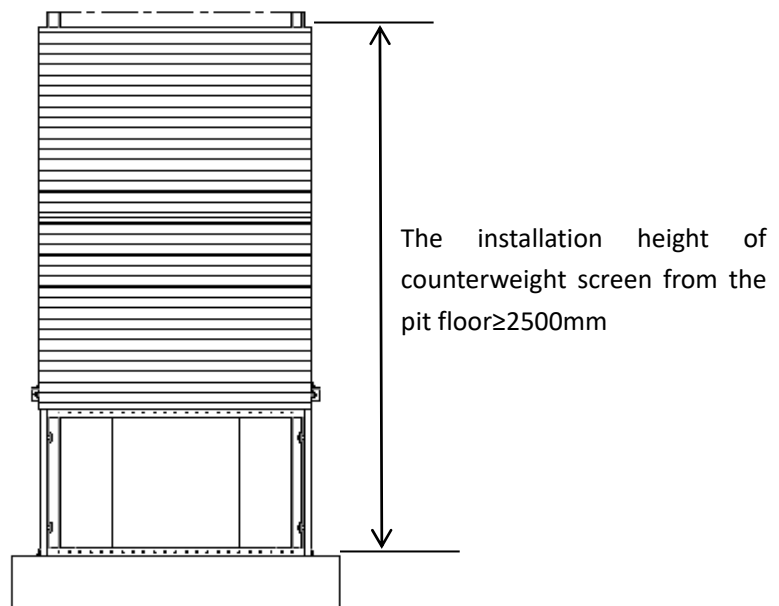

Figure 7-7

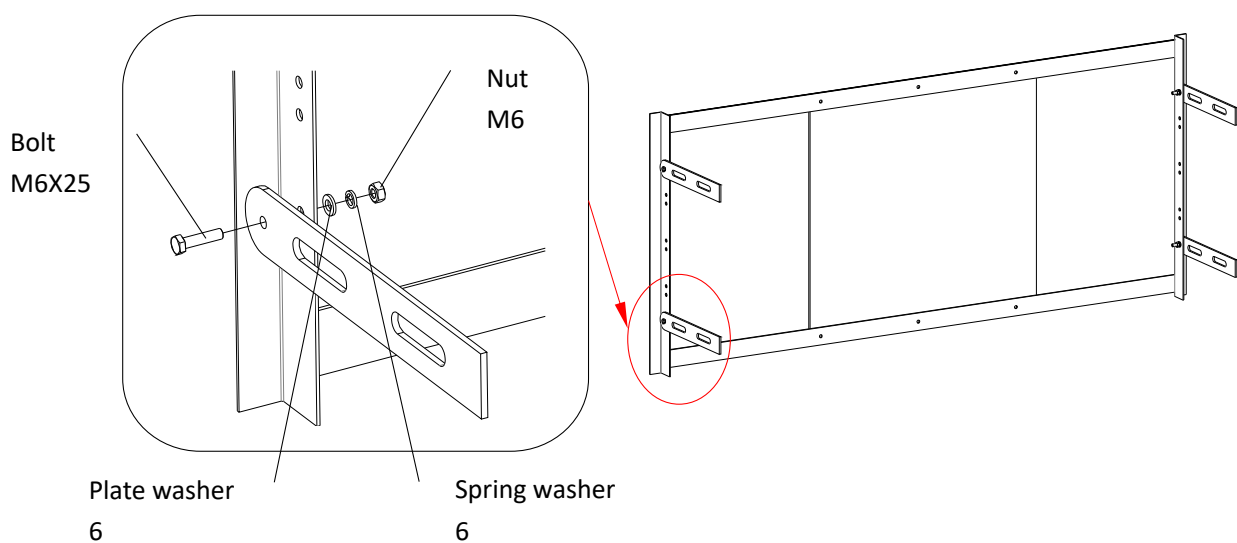
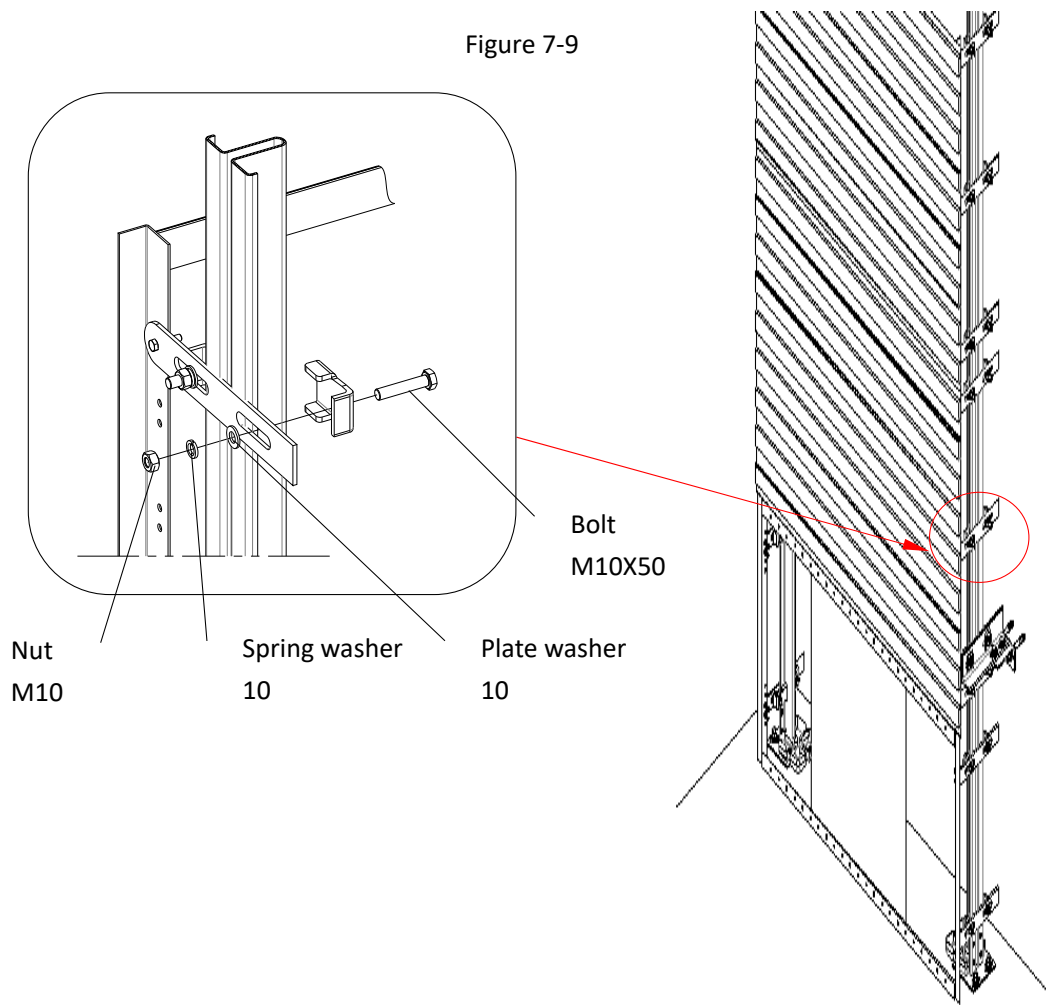

Figure 7-8

Figure 7-9





## 8 Installation of car frame

Car Frame installation overview:

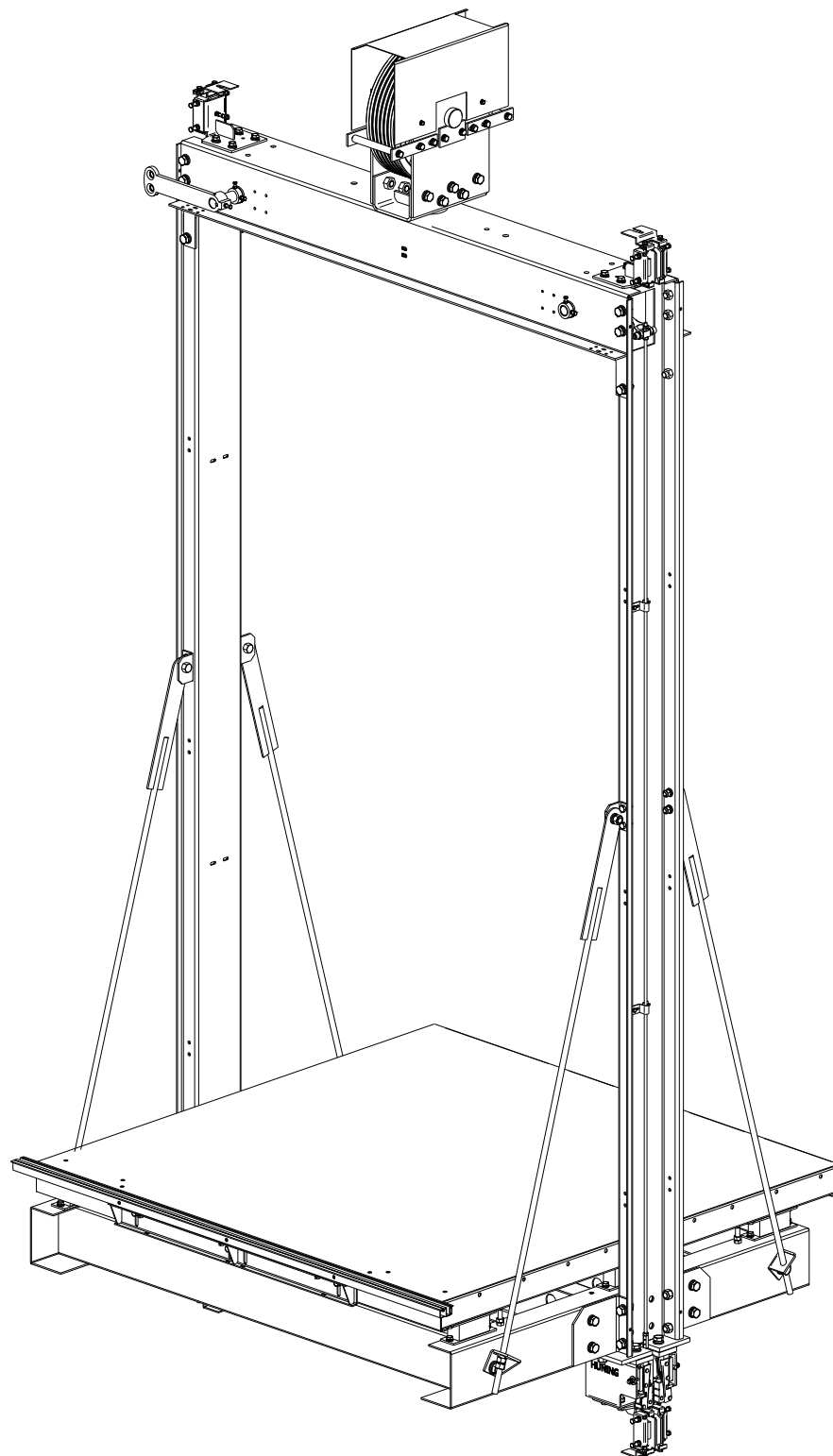

(CLD)

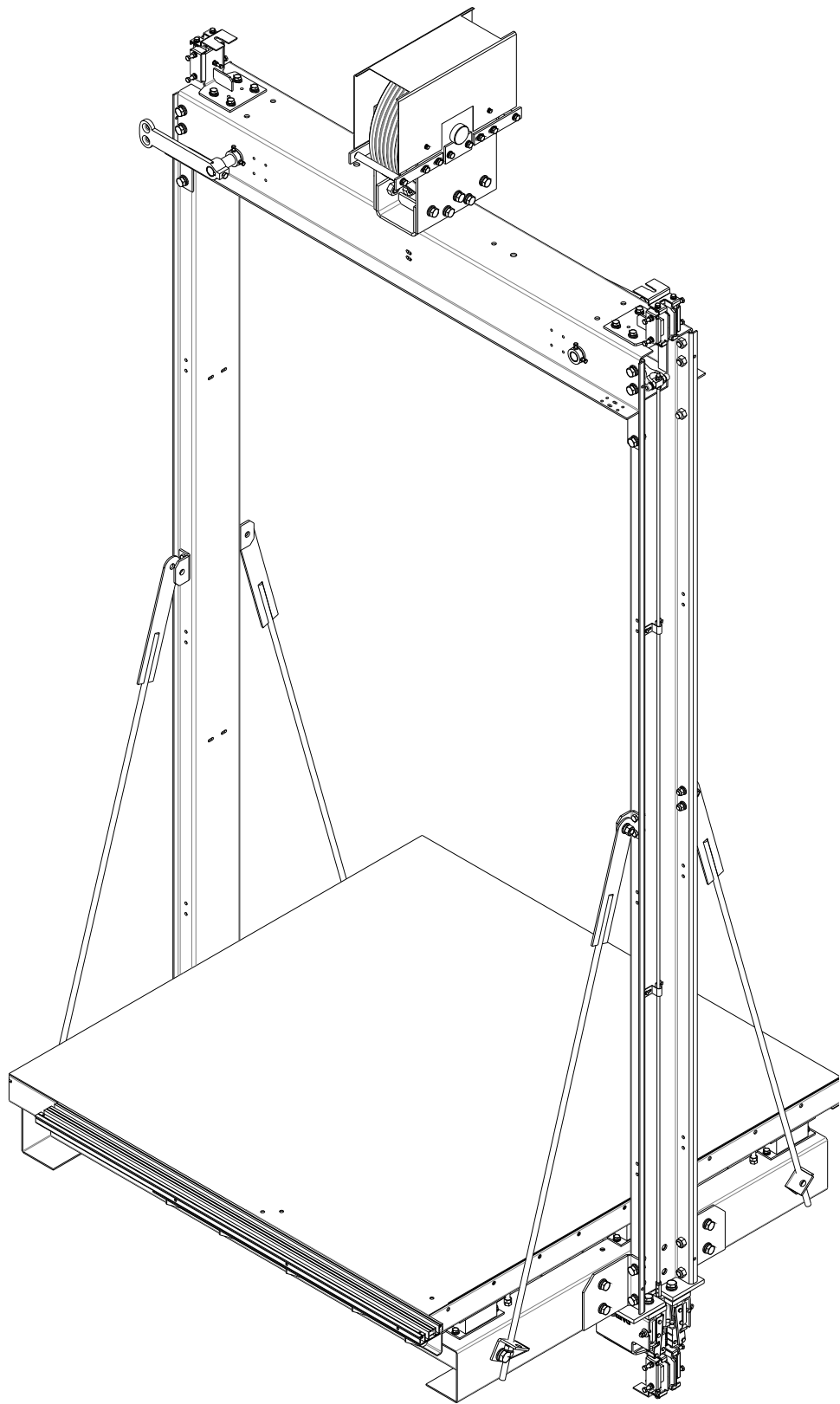

(TLD)

### 8.1 Installation of safety gear

Step	Instruction	Fig
1	Connect the safety gear fixing plate on sub-frame.	Figure 8-1
2	Connect the safety gear on sub-frame.	Figure 8-2

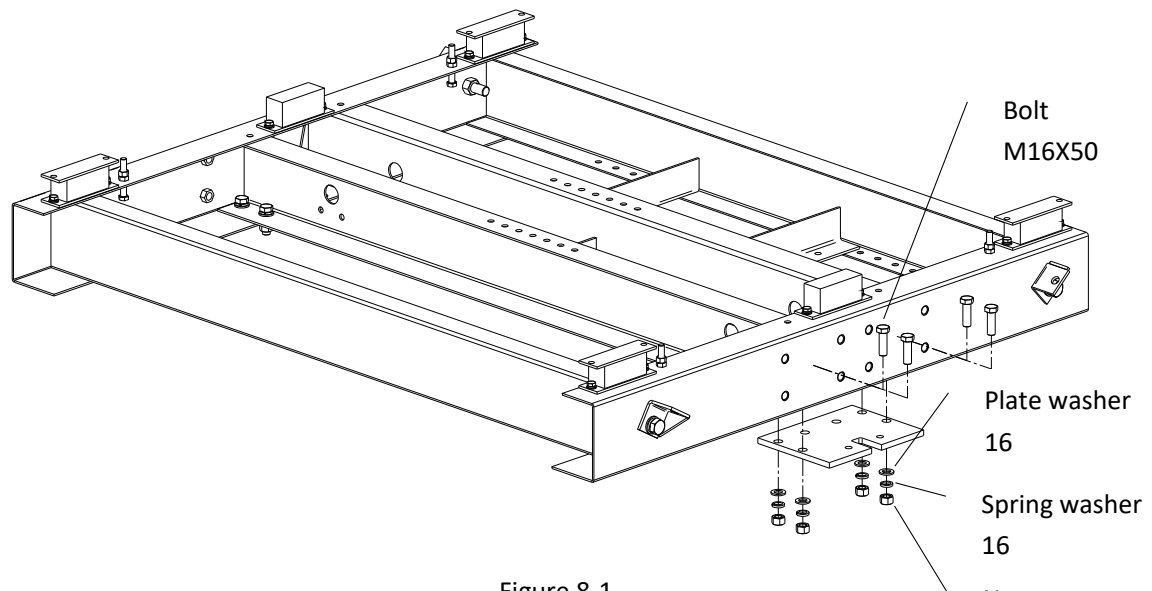

Figure 8-1

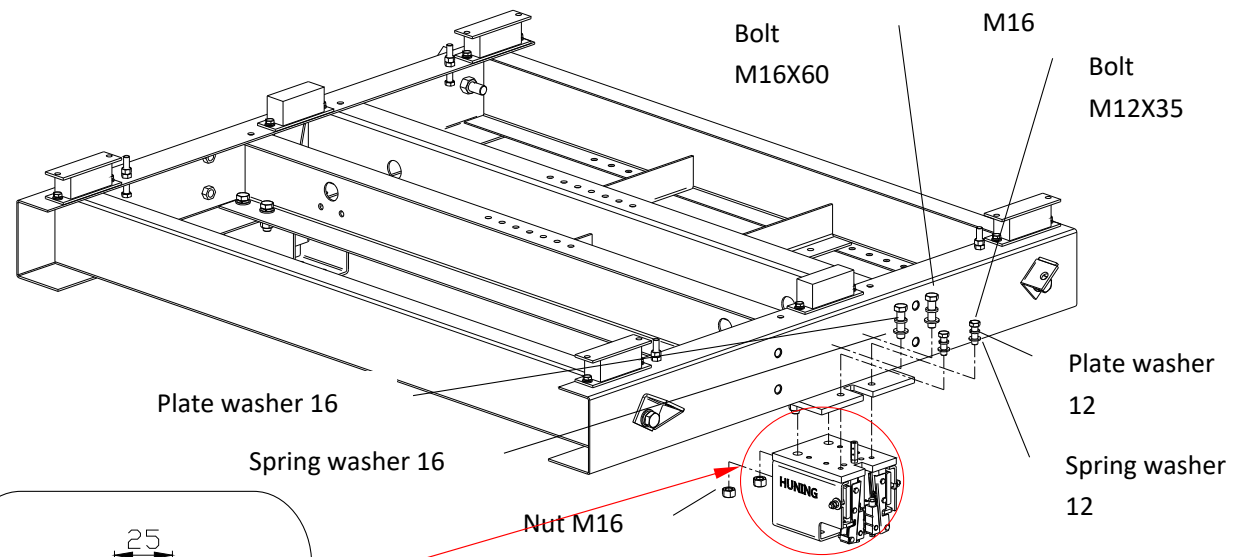
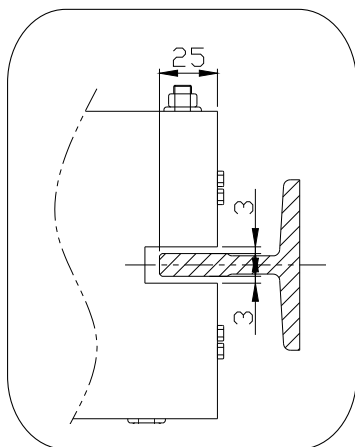

Figure 8-2



**Note:**

When install the safety gear, Distance on both sides of the safety gear with the guide surface of the wedge should be less than 0.5mm; distance deviation between the both sides work face of safety gear and the guide surface should not exceed 0.5mm.

## 8.2 Installation of sub-frame

Step	Instruction	Fig
1	Remove the scaffold in the top of hoist-way.	Figure 8-3
2	Put sub-frame in to hoistway and adjust the horizontality.	Figure 8-3

**Note:**  
 Before sub-frame was installed, all of the weight need to be installed on the buffer hit plate, Fastened must be fully locked!

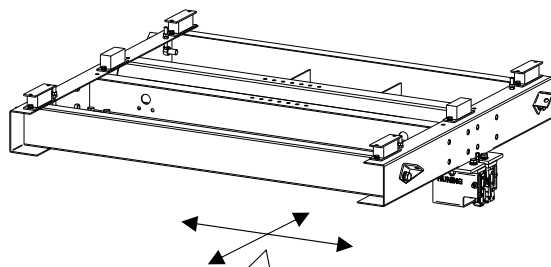

The horizontality deviation of the sub-frame should be less than 1/1000.

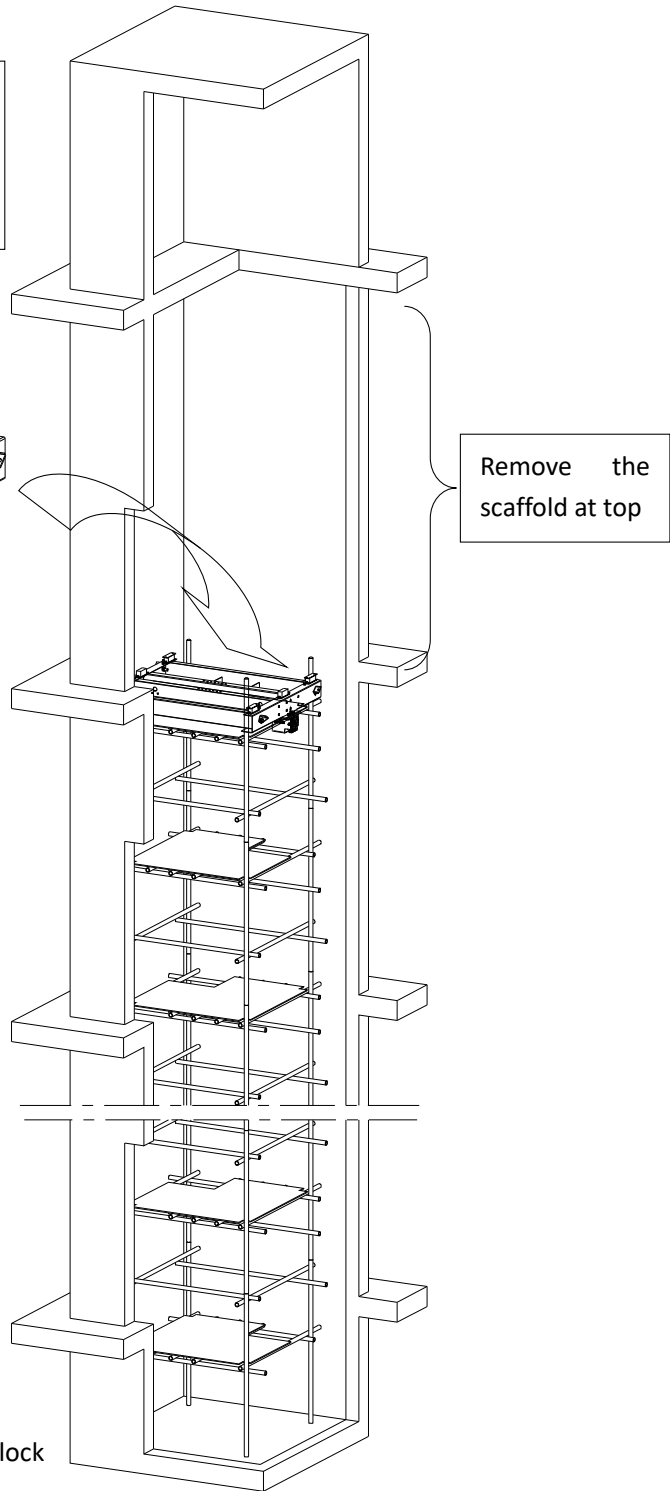
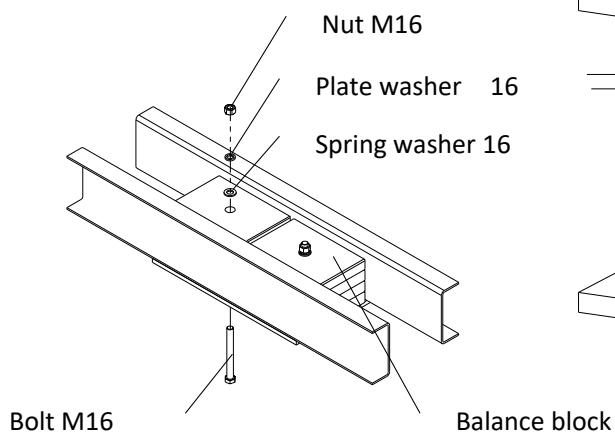

Figure 8-3

### 8.3 Installation of bottom guide

Step	Instruction	Fig
1	Install the bottom guide shoes on safety gear.	Figure 8-4
2	The roller guide throat center match with guide rail center.	Figure 8-5(1)
3	The side roller spring force adjusted to 3-5mm compression. The stop nut clearance adjusted to 2-3mm.	Figure 8-5(2)
4	The front roller spring force adjusted to 2-4mm compression. The stop nut clearance adjusted to 2-3mm.	Figure 8-5(3)

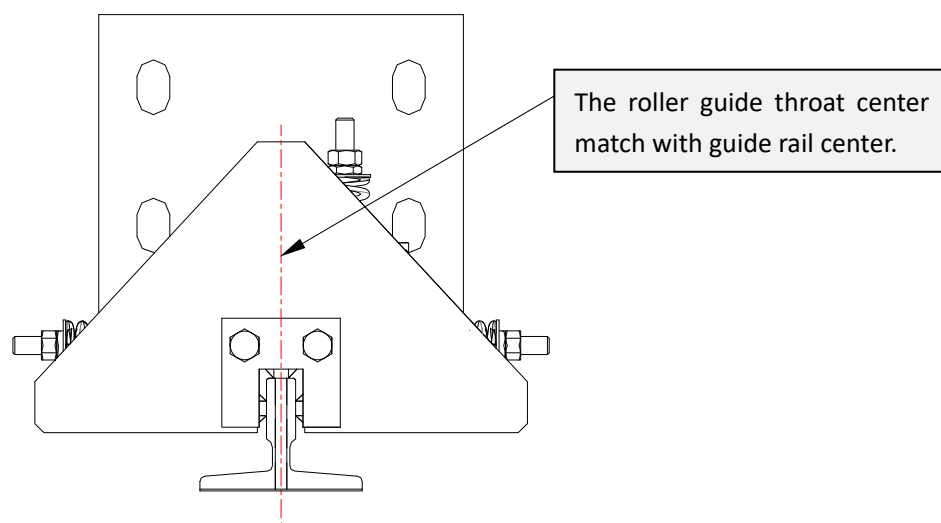
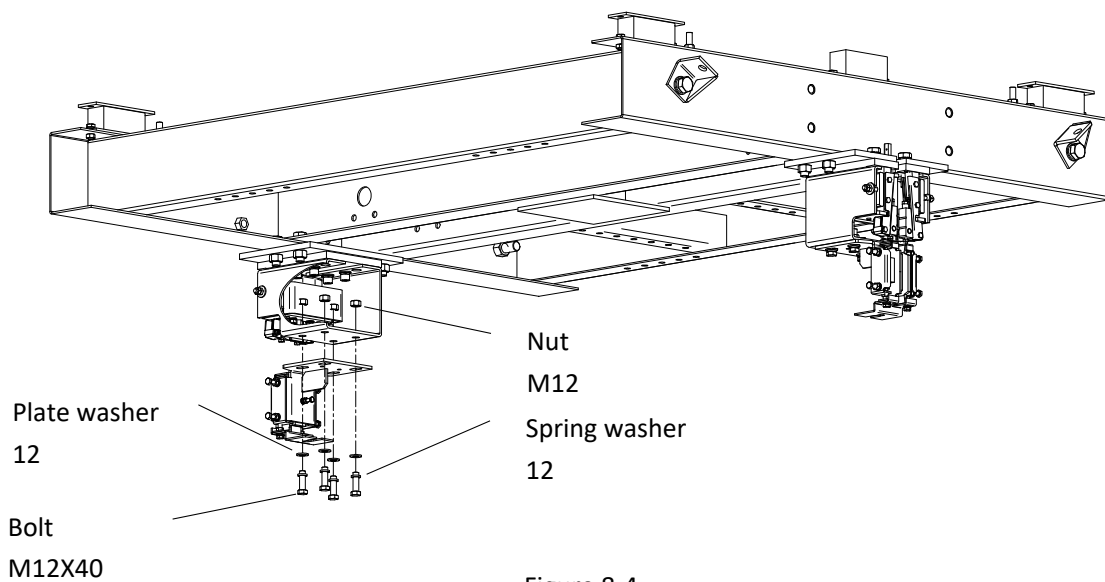

Figure 8-5 (1)

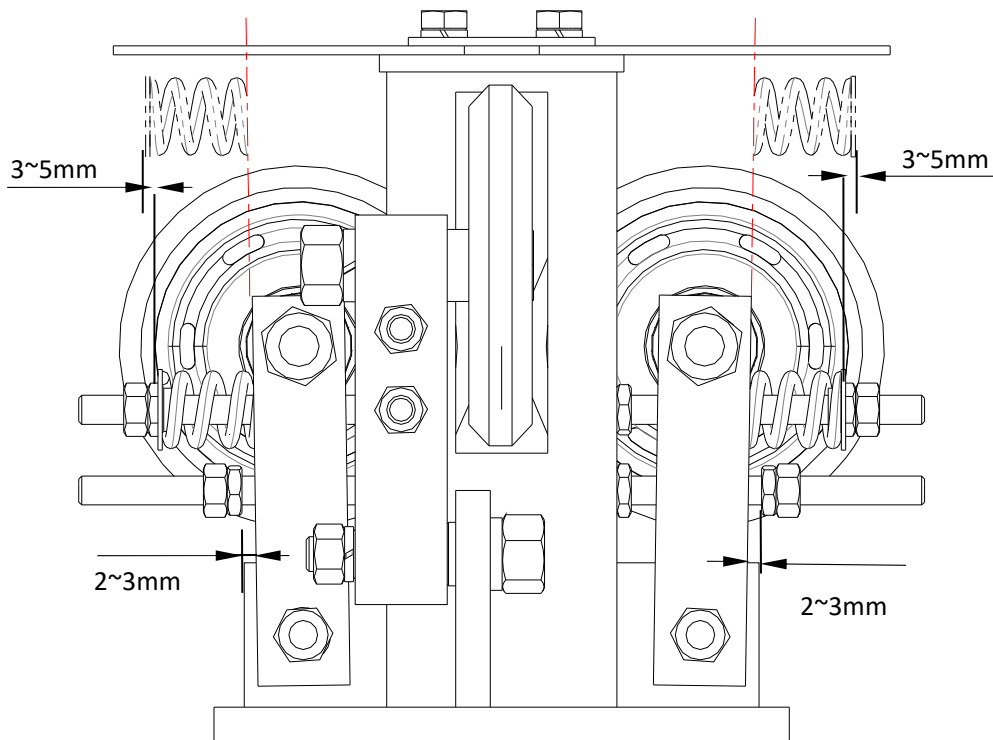

Figure 8-5 (2)

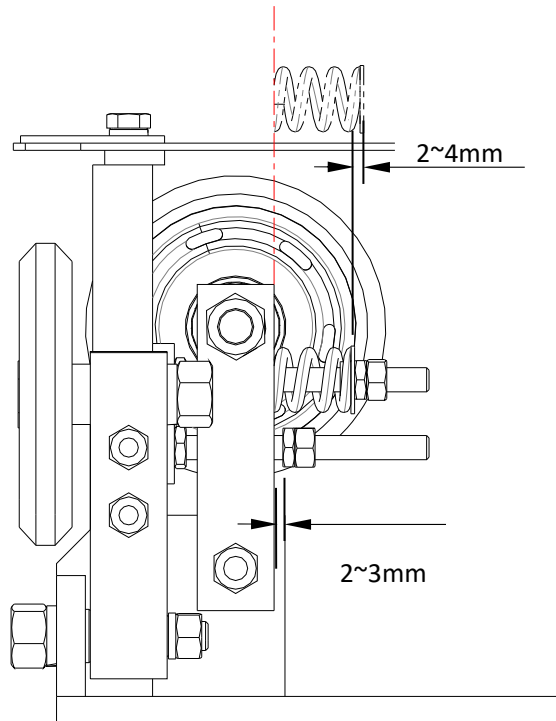

Figure 8-5 (3)

---

**8.4 Installation of uprights**

Step	Instruction	Fig
1	Fix bottom of uprights on the sub-frame.	Figure 8-6
2	Installation of side braces.	Figure 8-7

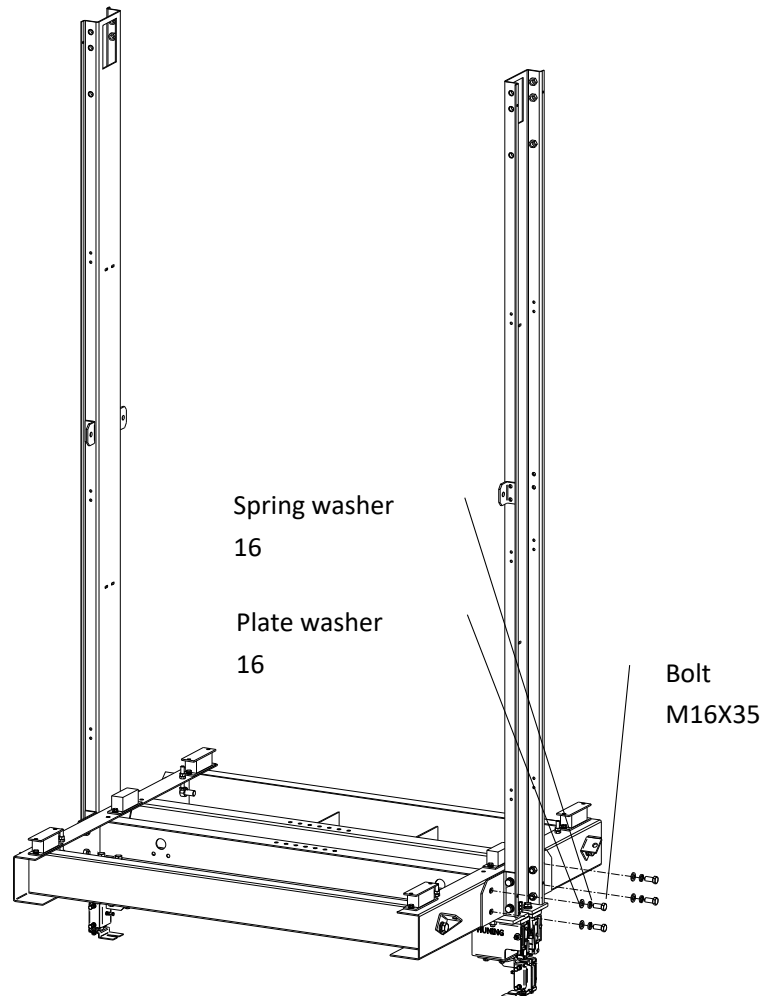

Figure 8-6

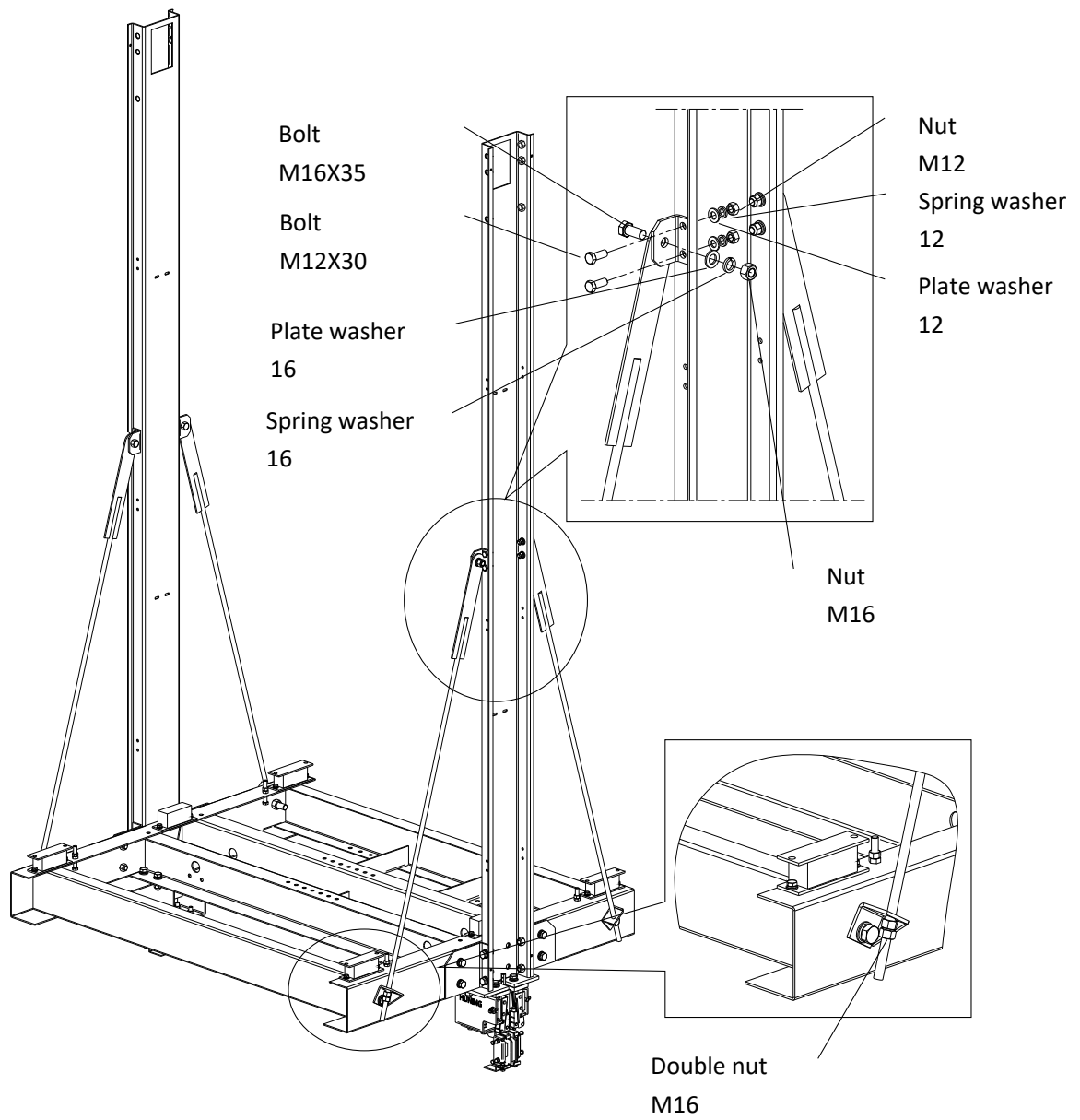

Figure 8-7



### 8.5 Installation of crosshead

Step	Instruction	Fig
1	Installation of cross-head beam. (DL≤1000Kg & V≤1.75m/s)	Figure 8-8 (1)
	Installation of cross-head beam. (DL>1000Kg or V>1.75m/s)	Figure 8-8 (2)

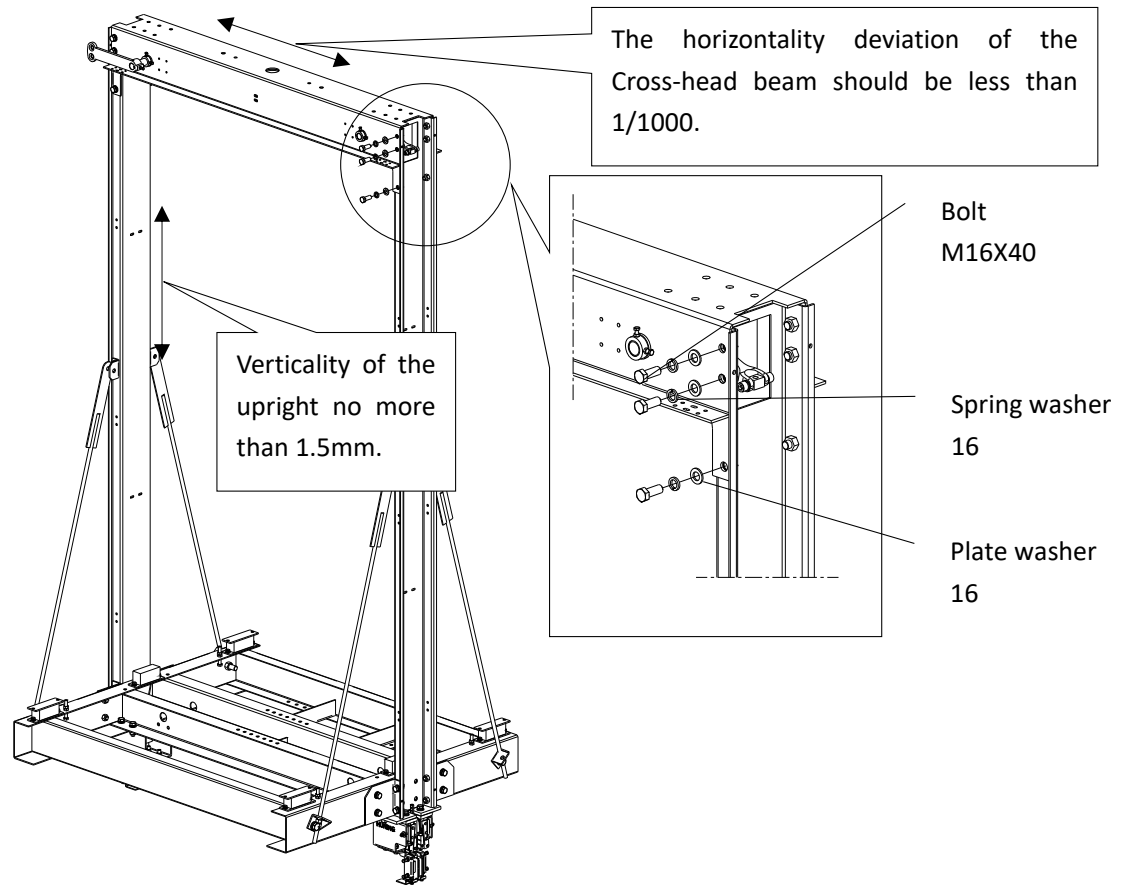
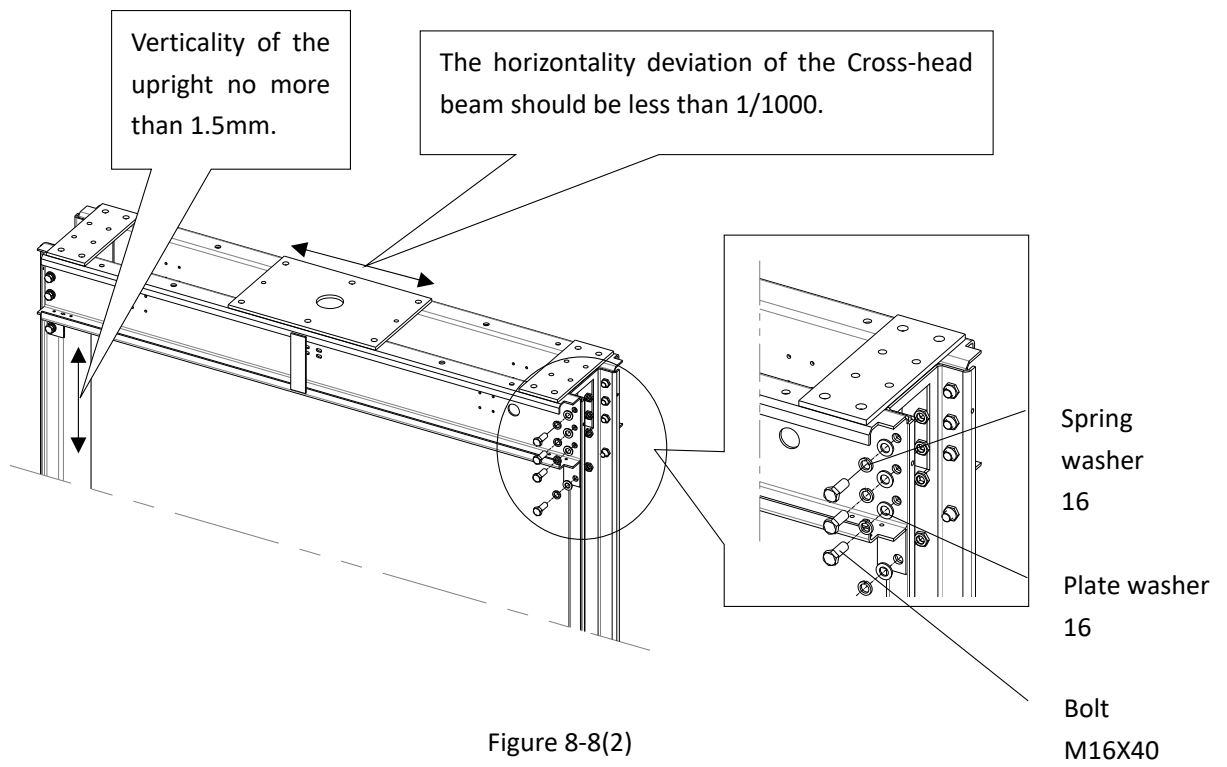

Figure 8-8(1)



### 8.6 Installation of top guide

Step	Instruction	Fig
1	Installation of top guide shoes, fix on the crosshead. ( $DL \leq 1000\text{Kg}$ & $V \leq 1.75\text{m/s}$ )	Figure 8-9 (1)
	Installation of top guide shoes, fix on the crosshead. ( $DL > 1000\text{Kg}$ or $V > 1.75\text{m/s}$ )	Figure 8-9 (2)

Verticality of top guide  
no more than 1mm

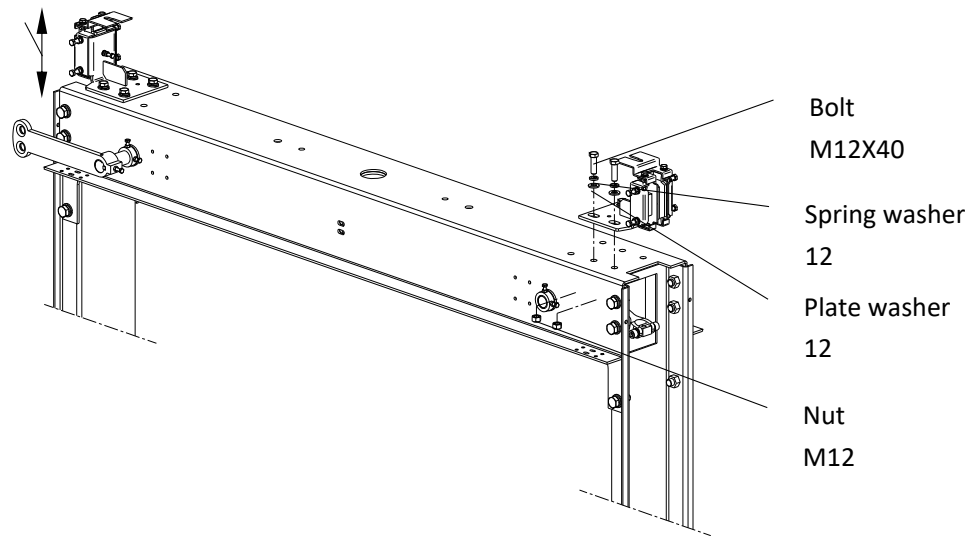

Figure 8-9 (1)

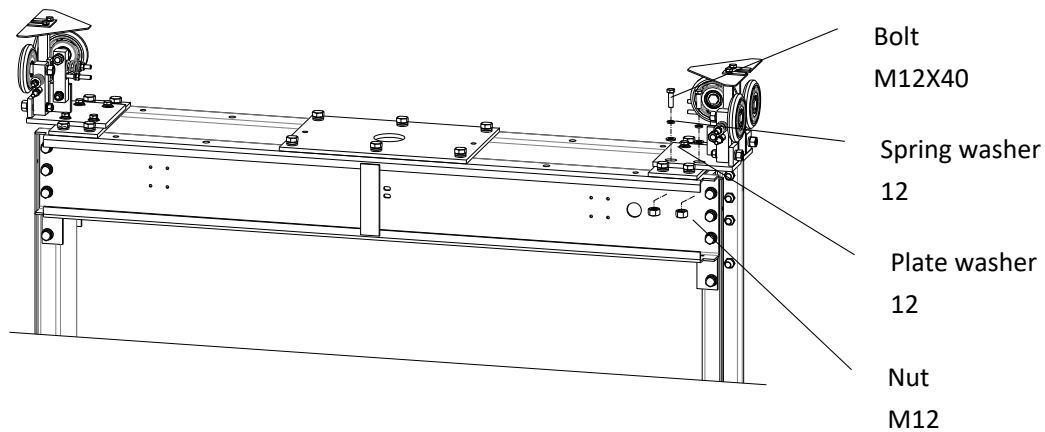

Figure 8-9 (2)

**Note:**

The clearance between guide rail top surface and guide rail shoe is 1-2mm;  
Please refer to 8.2 for roller guide adjustment.

## 8.7 Installation of safety linkage

Step	Instruction	Fig
1	Adjust the safety linkage on the crosshead.	Figure 8-10
2	Install the lift rod, top connect on linkage, bottom connect with safety wedge.	Figure 8-11
3	Install lift rod guider on upright.	Figure 8-11

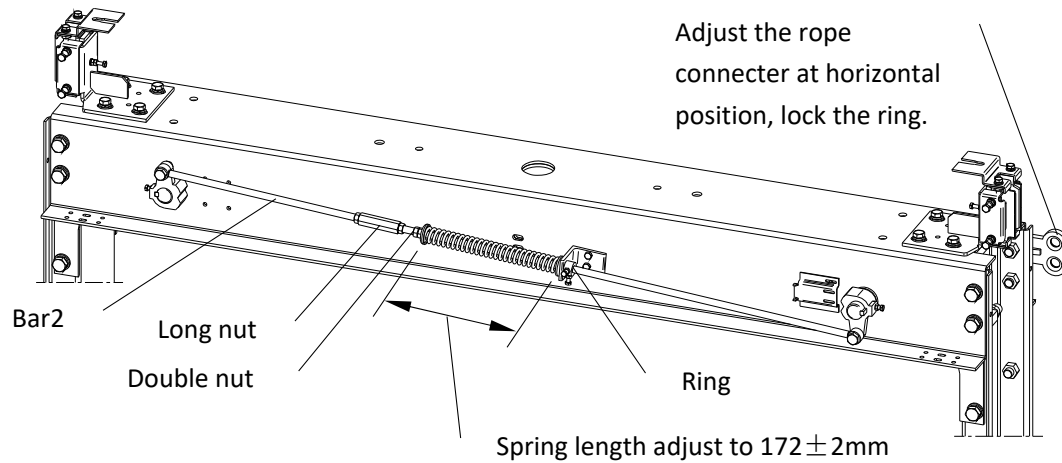

Figure 8-10

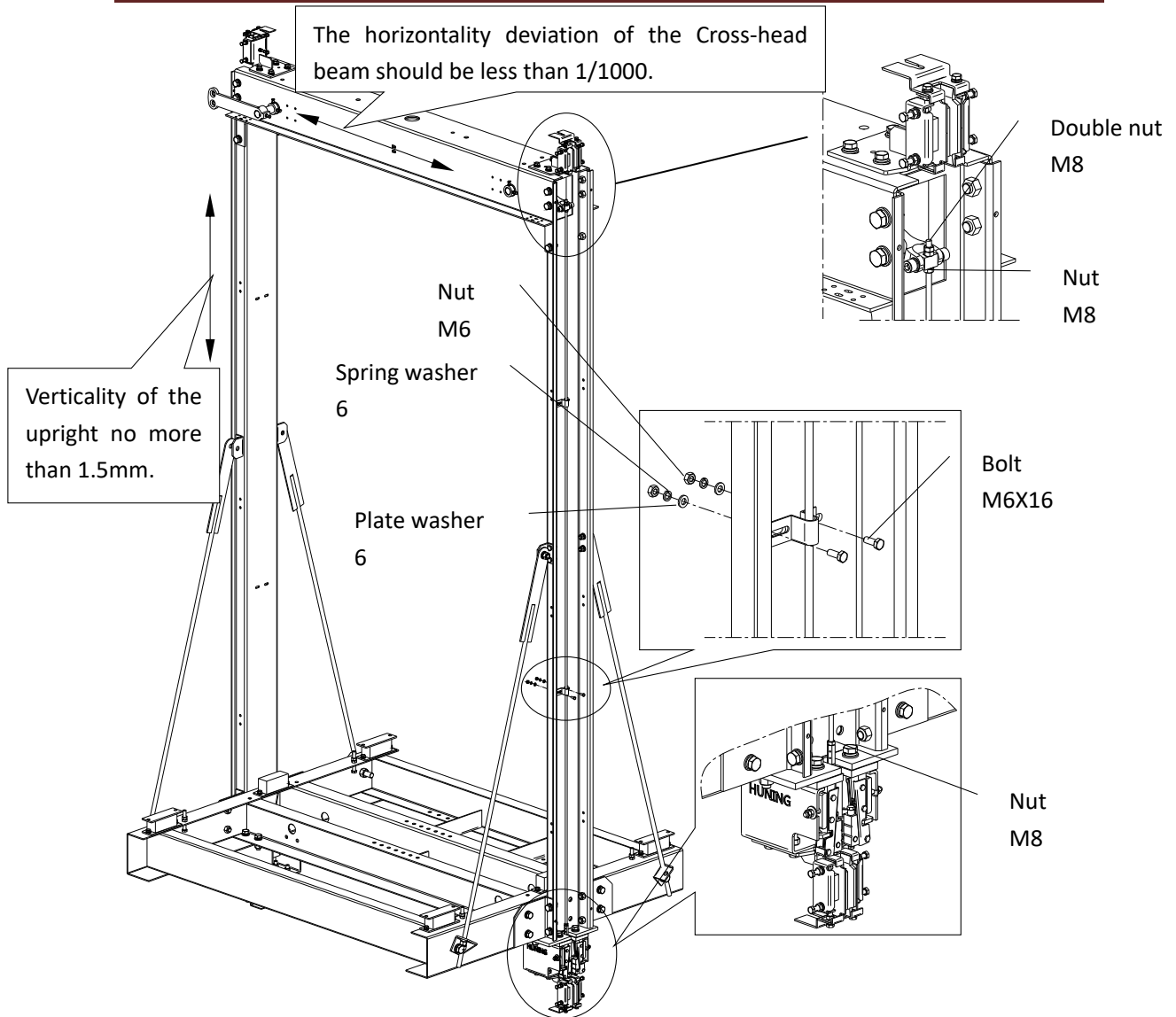

Figure 8-11

### 8.8 Installation of top of car sheave

Step	Instruction	Fig
1	Install top of car sheave on crosshead. ( $DL \leq 1000\text{Kg}$ & $V \leq 1.75\text{m/s}$ )	Figure 8-12(1)
	Install top of car sheave on crosshead. ( $DL > 1000\text{Kg}$ or $V > 1.75\text{m/s}$ )	Figure 8-12(2)

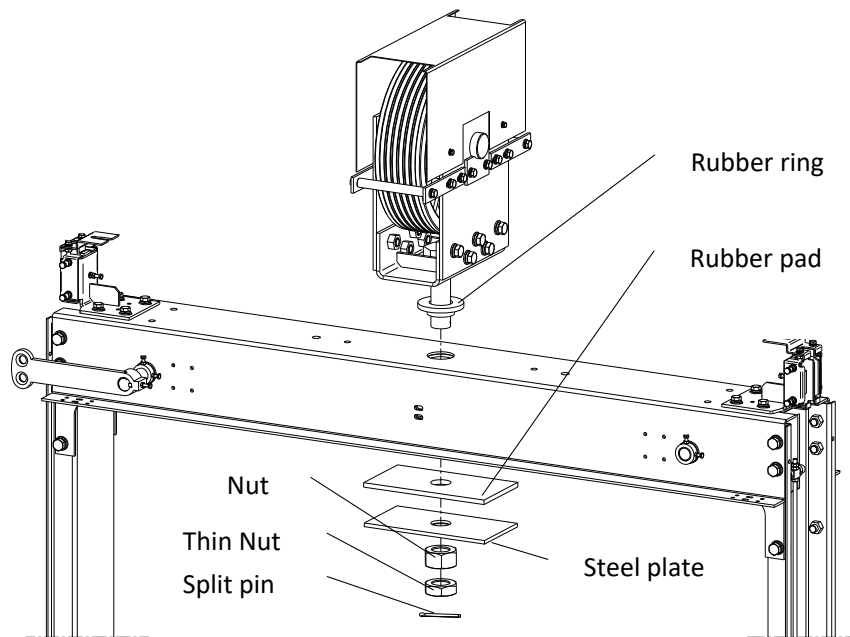

Figure 8-12(1)

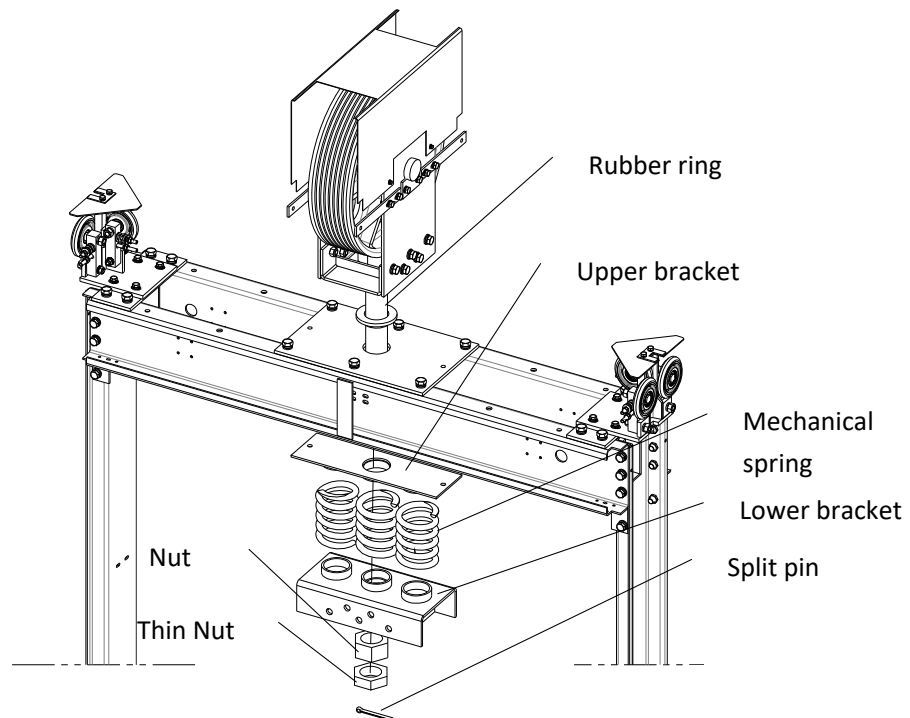

Figure 8-12(2)

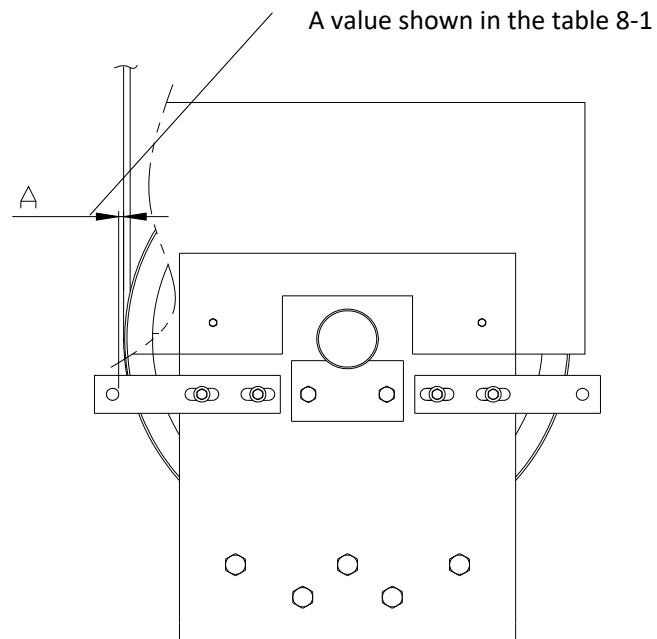

figure 8-12(3)

Diameter of rope d	Φ8	Φ10	Φ12	Φ13
The gap between rope and rope lever block A	1~2mm	2~3mm	2~3mm	2~4mm

Counterweight sheave and the guide sheave apply the same criteria.

Table 8-1

## 8.9 Installation of platform

Step	Instruction	Fig
1	Install the platform on sub-frame.	Figure 8-13
2	Install car door sill support and sill.	Figure 8-14
3	Install the toe guard to the bracket of sill.	Figure 8-15
4	Adjust anti-pressure bolts and platform gap (after installation of the lift)	Figure 8-16

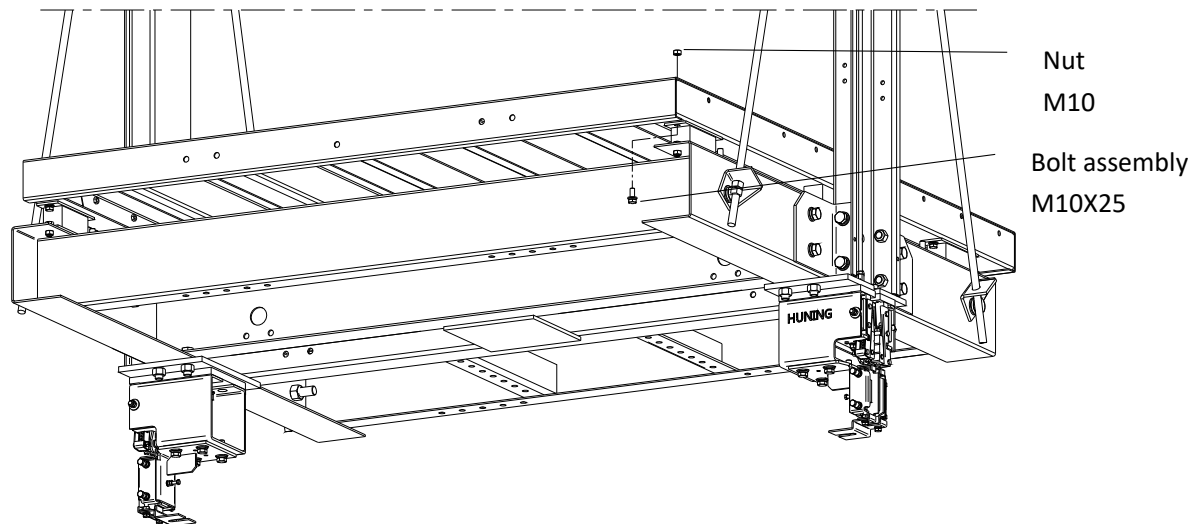

Figure 8-13 (CLD)

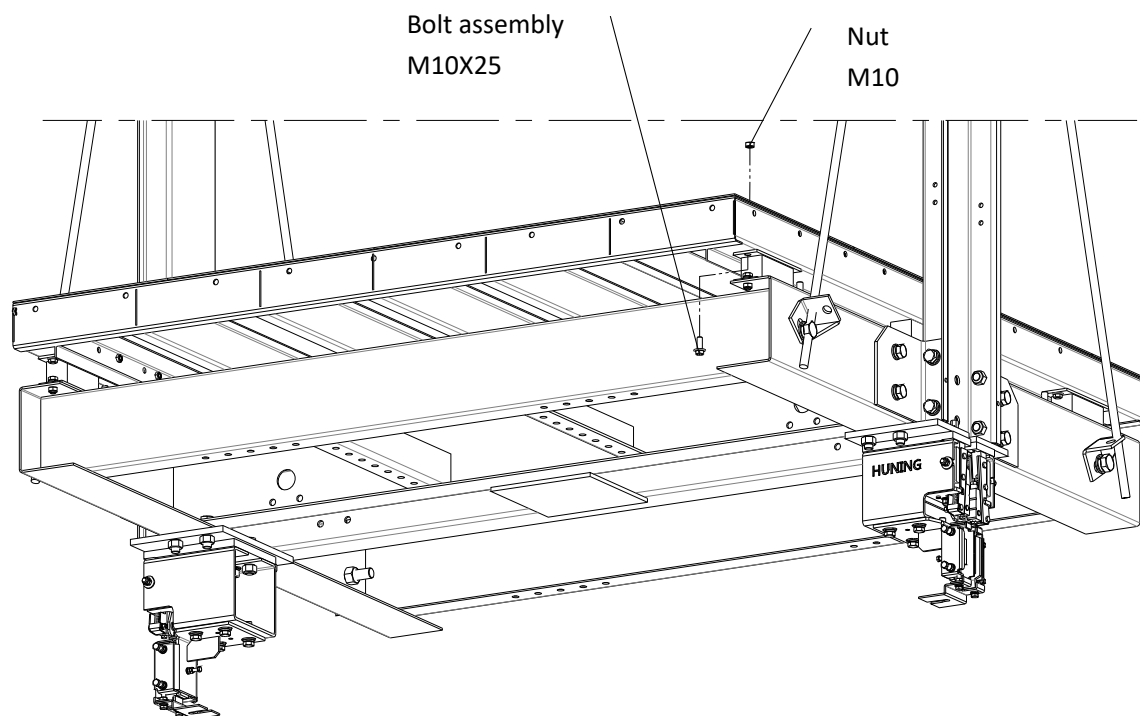



Figure 8-13 (TLD)

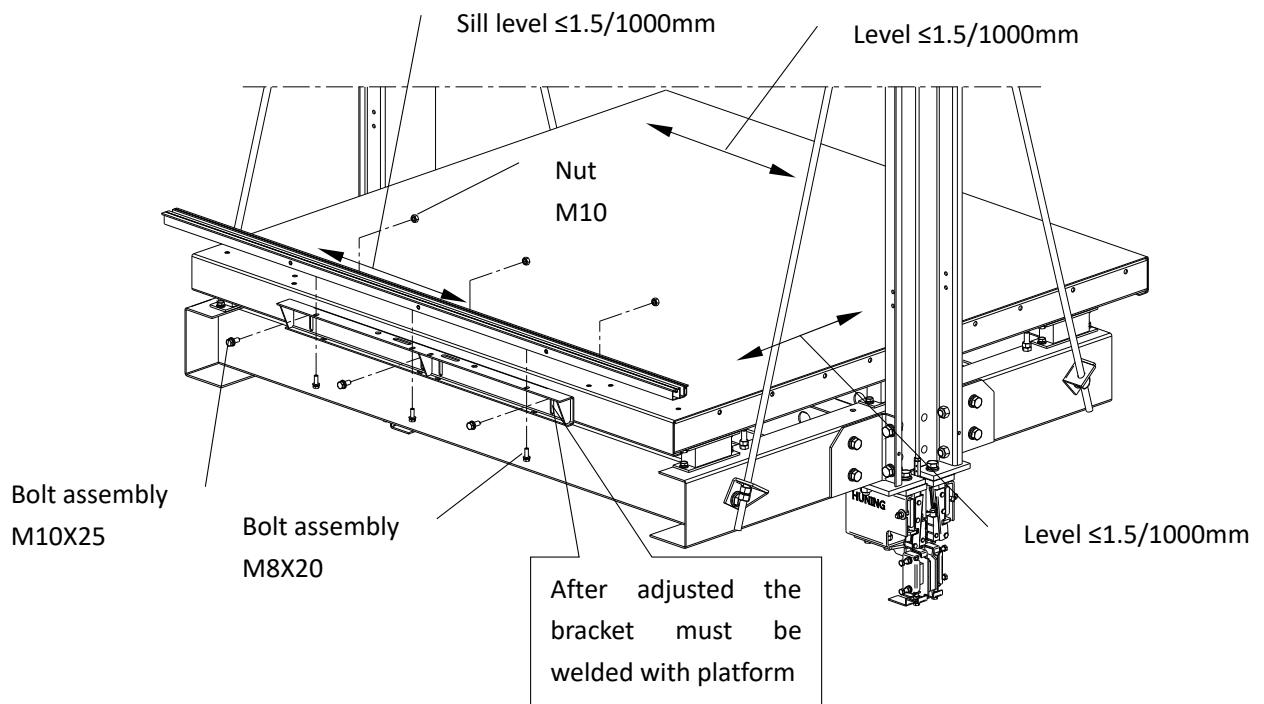

Figure 8-14(CLD)

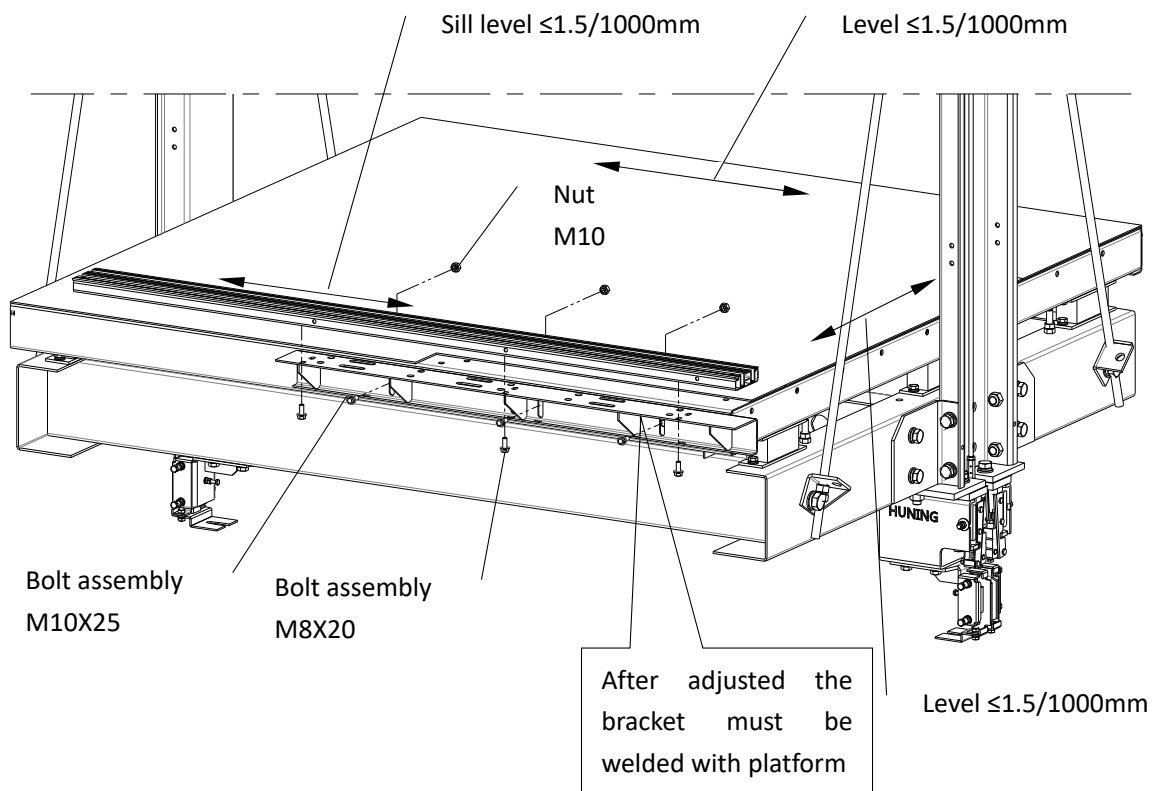

Figure 8-14(TLD)

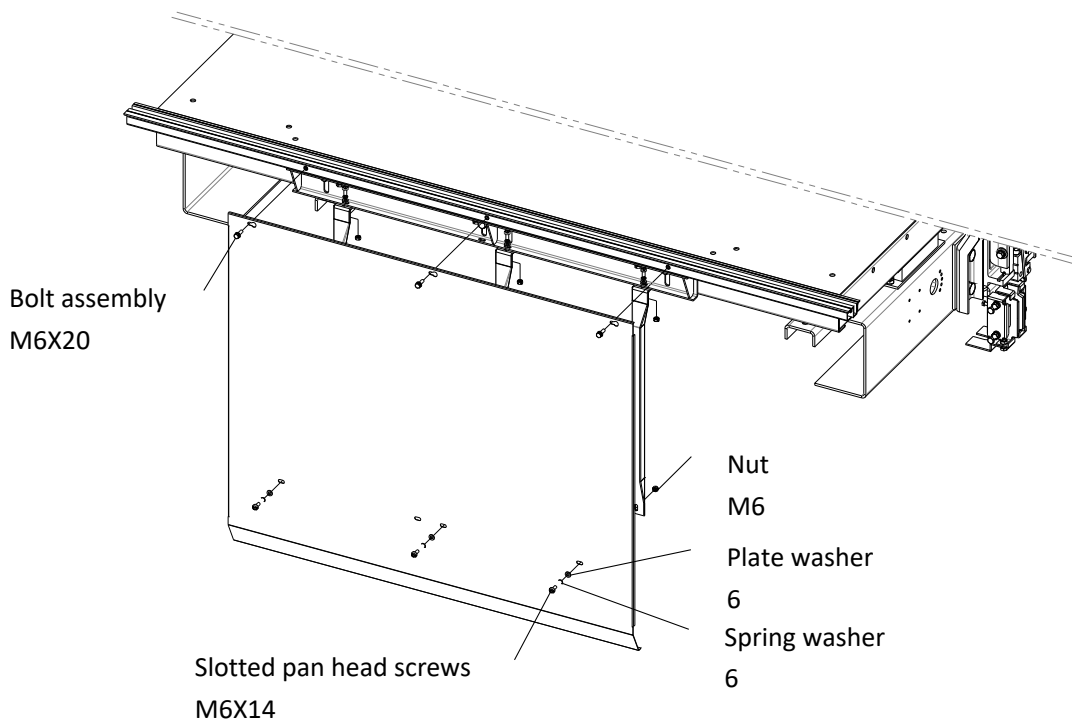

Figure 8-15(CLD)

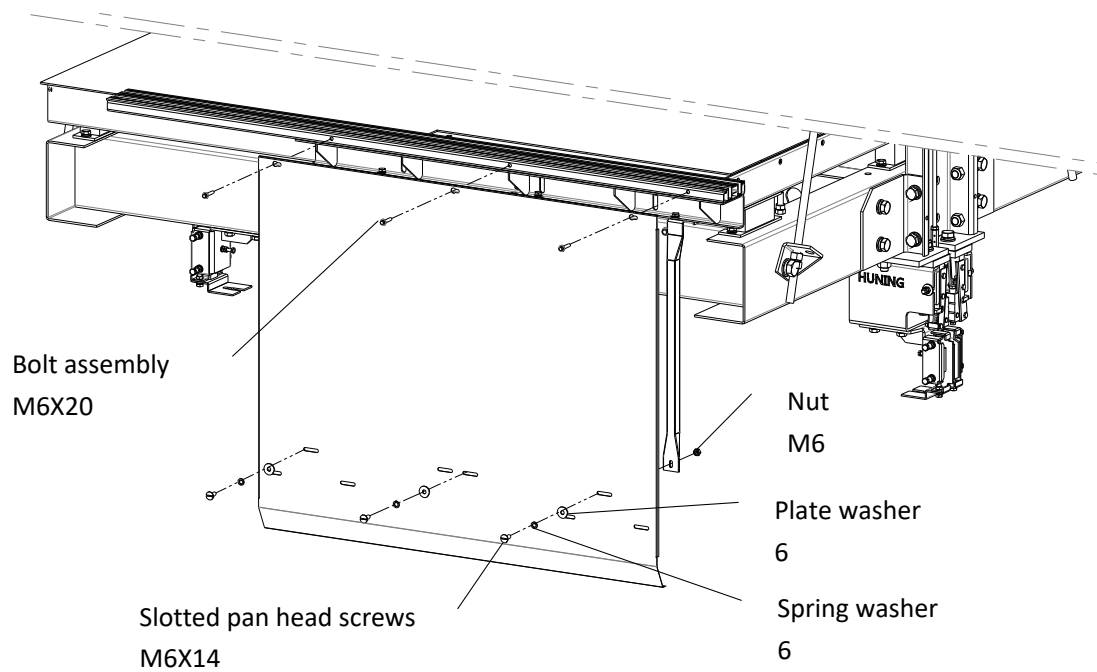

Figure 8-15(TLD)

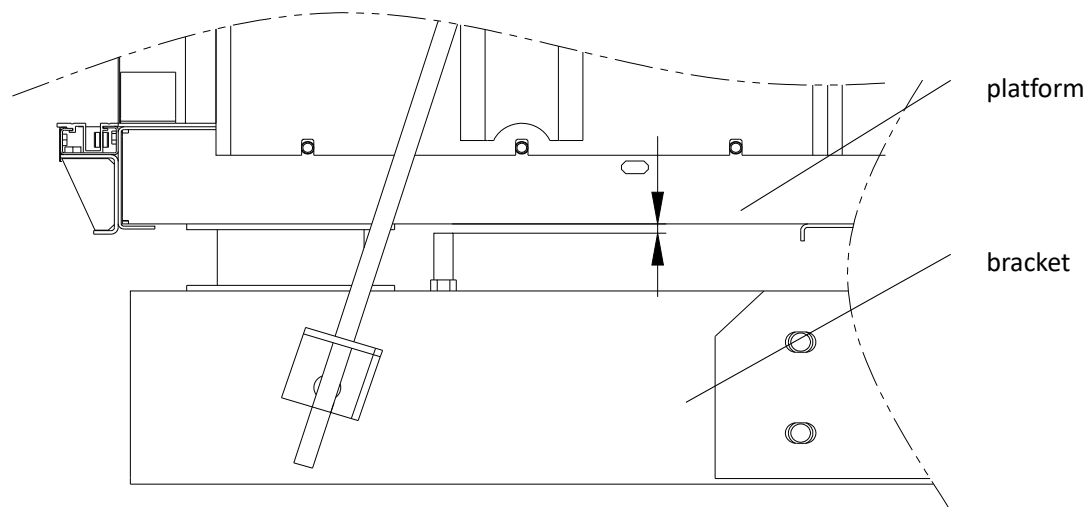

figure 8-16

**Note:**

Adjust the limit bolt to ensure the distance between bolt and platform is 0mm when 125% in car.

---

**8.10 Install the balance block**

step	instruction	fig
1	All of balance blocks are installed on the blacket	figure 8-17

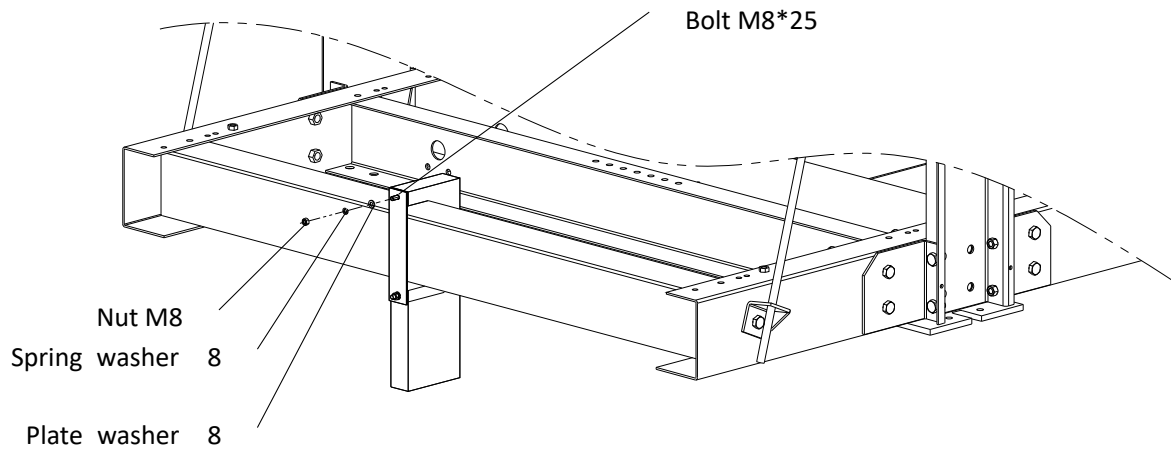

figure 8-17

**Note:**

Balance weight installation shall be installed base on the car inbalance test.

## 9 Installation of traction rope

Step	Instruction	Fig
1	Hanging method of steel wire rope.	Figure 9-1
2	Hanging method of steel wire rope (top view).	Figure 9-2
3	Connect the end of rope with rope termination; Fox termination on dead-end hitch plate.	Figure 9-3
4	Install termination anti-rotate rope.	Figure 9-4

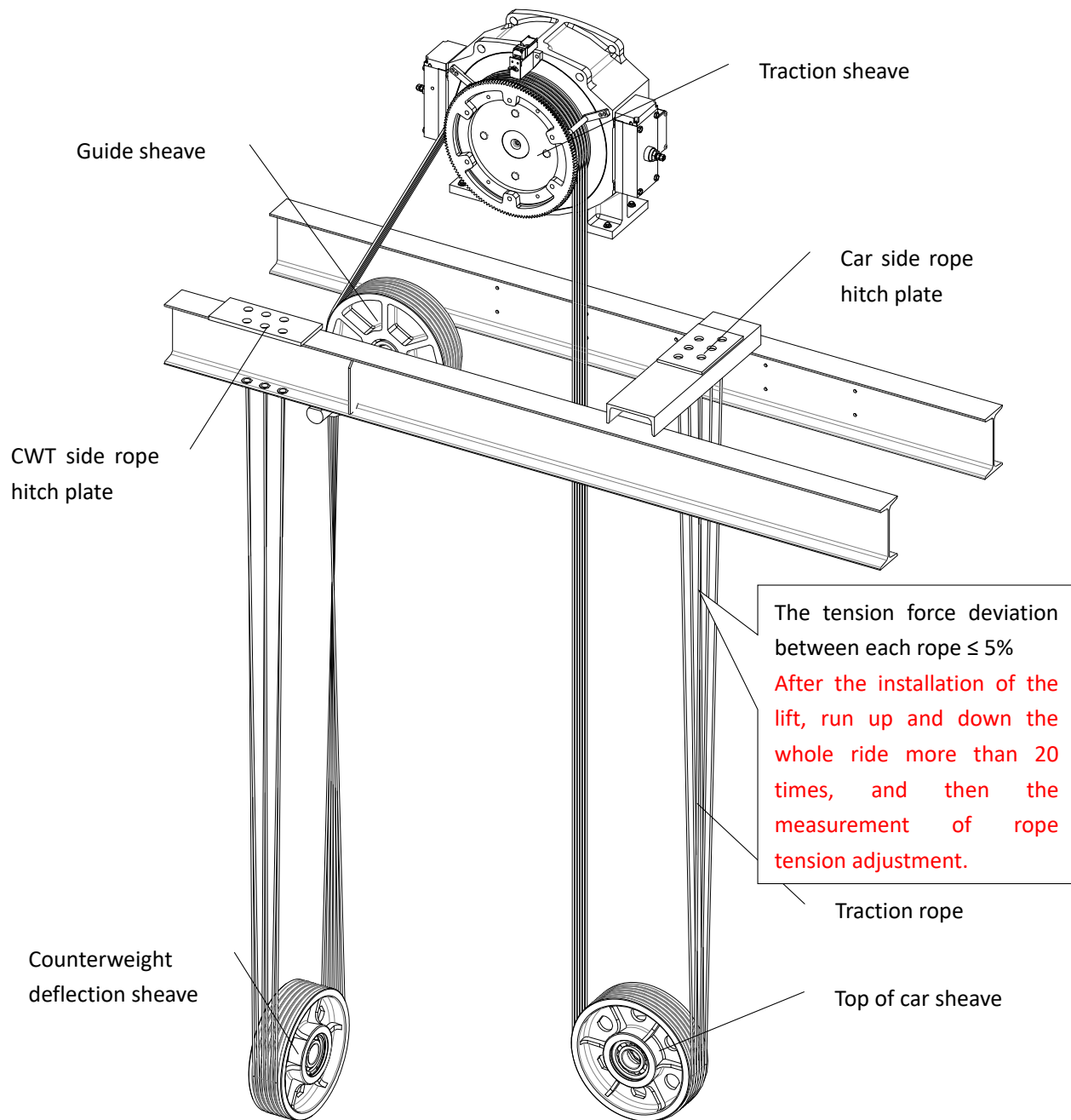

Figure 9-1

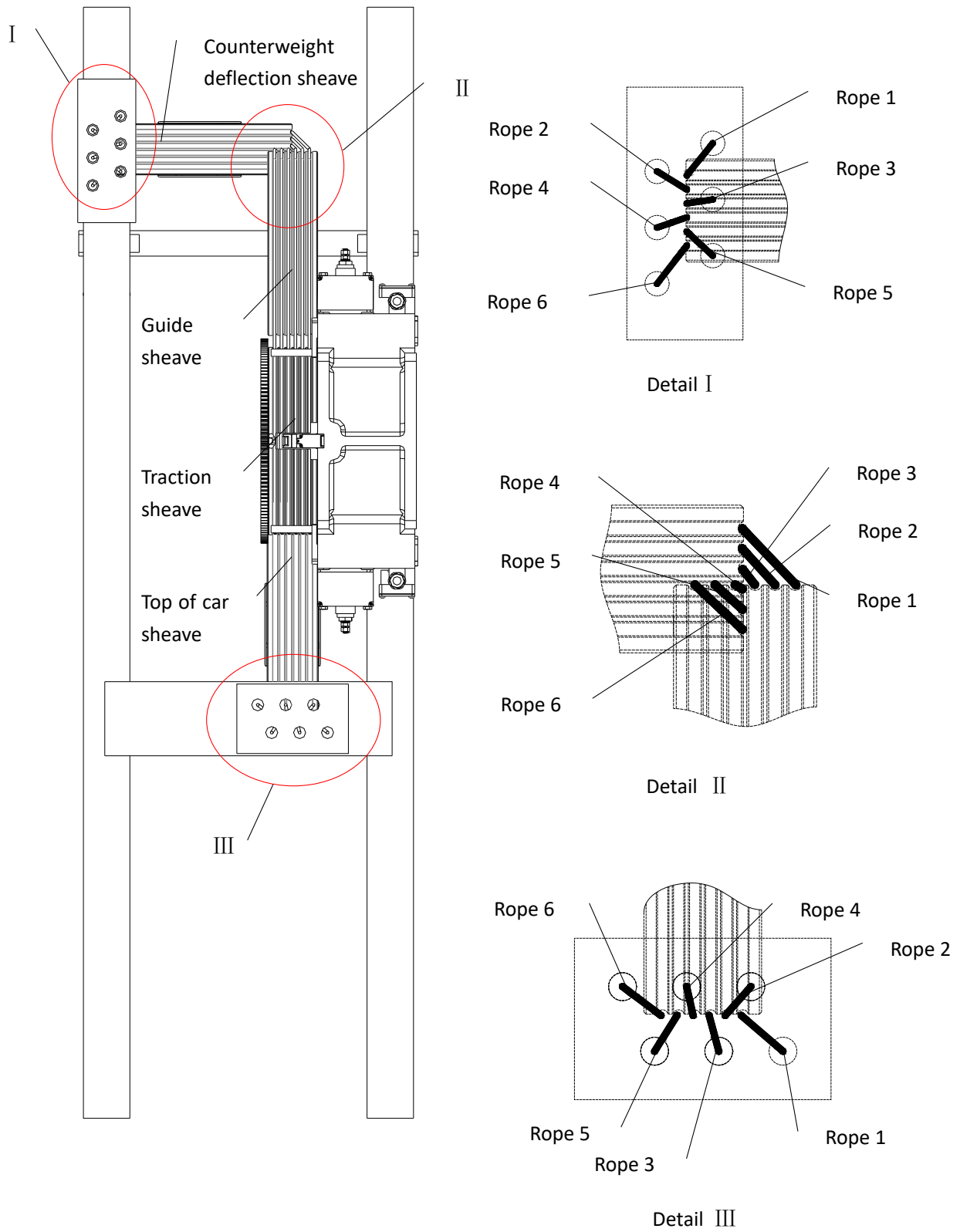

Figure 9-2

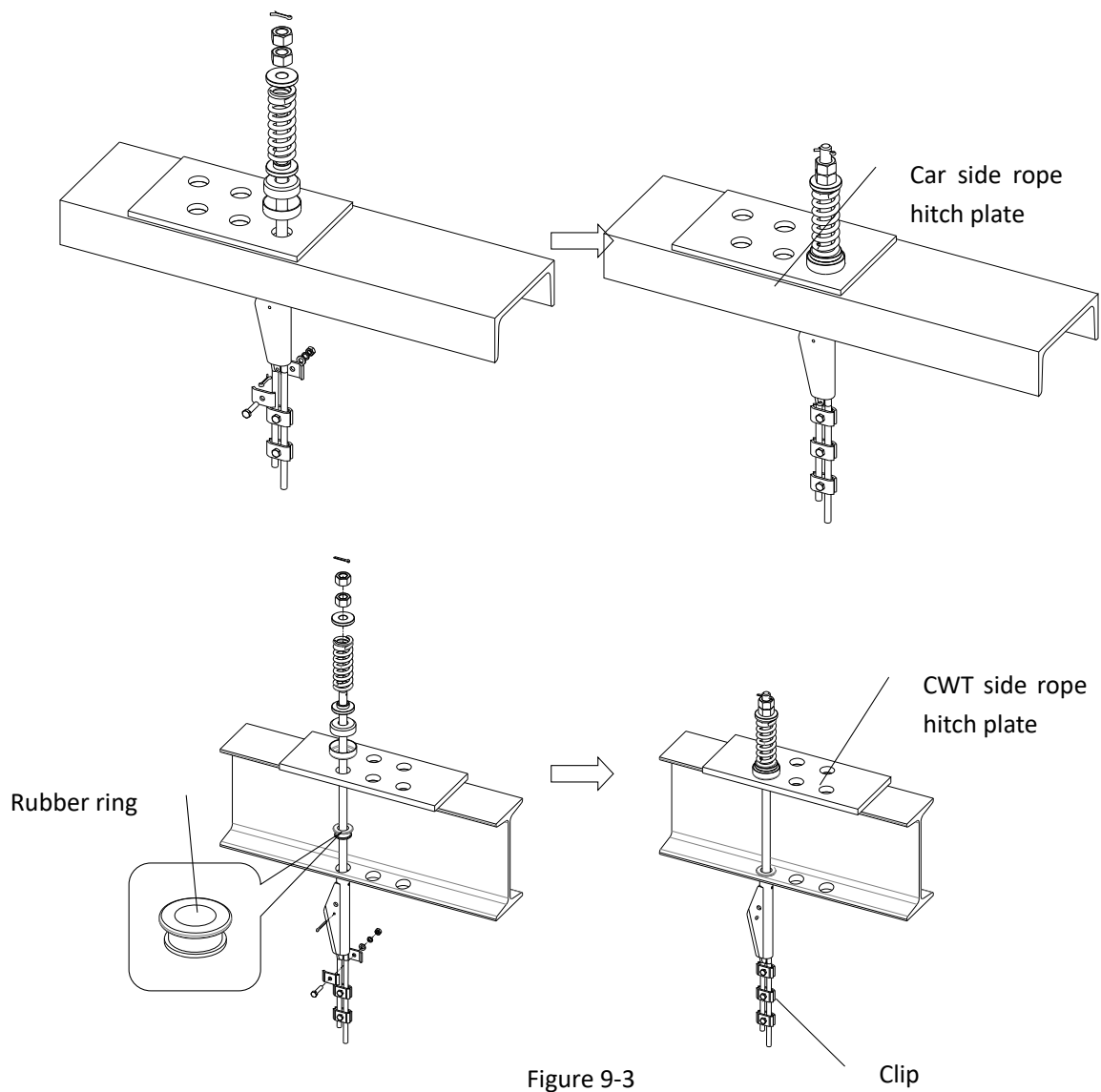

Figure 9-3

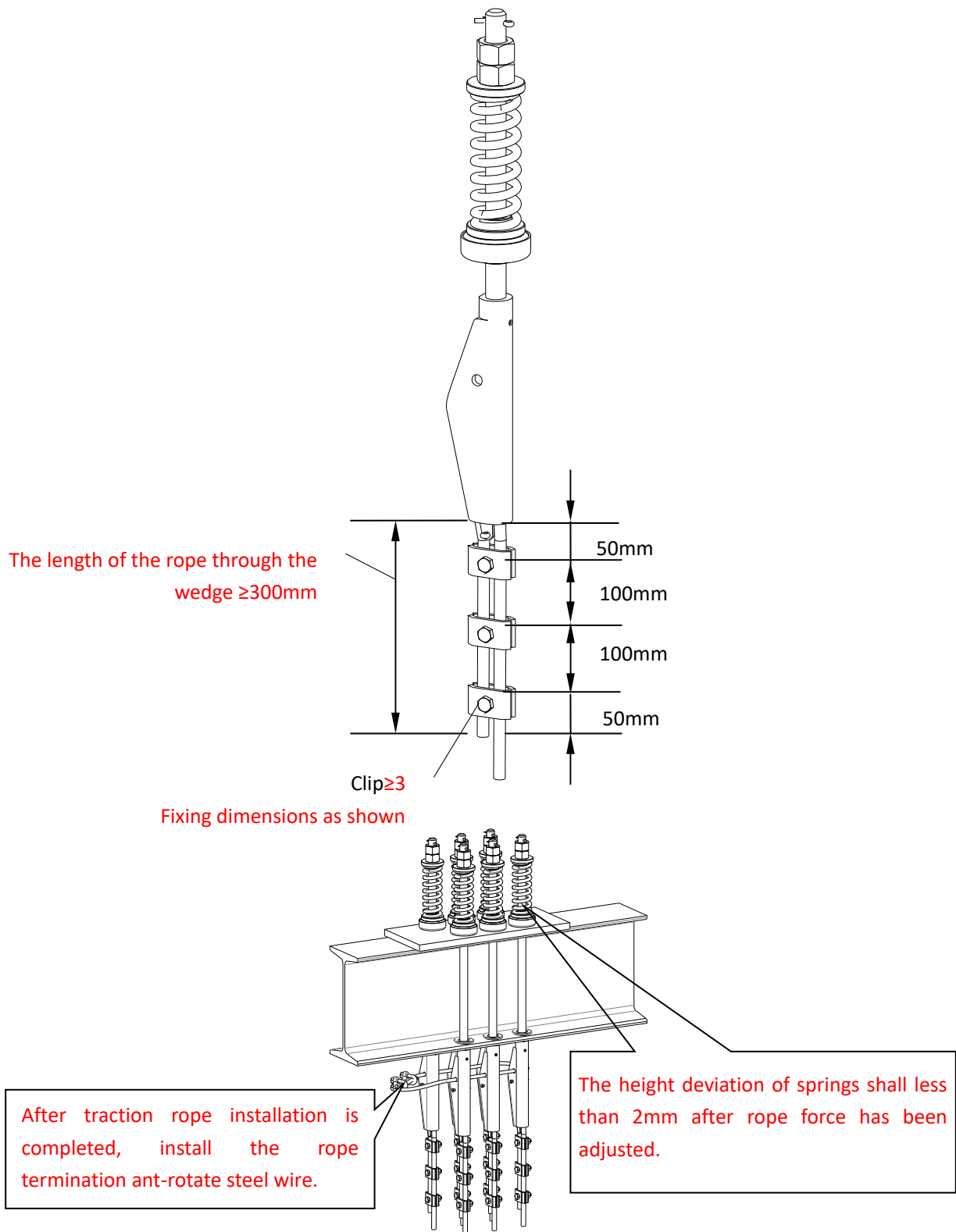

Figure 9-4



---

## 10 Installation of hoistway mechanical components

Hoistway mechanical components installation overview:

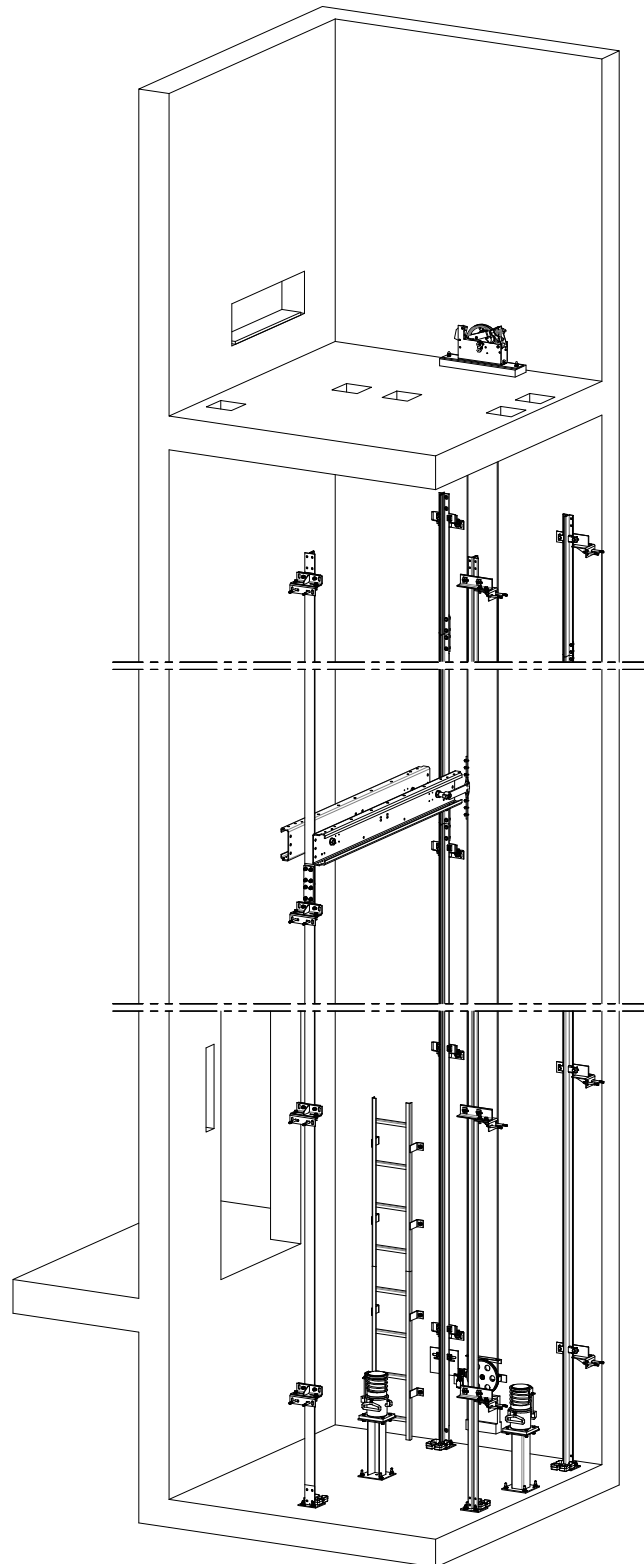

### 10.1 Installation of pit ladder

Step	Instruction	Fig
1	Stand the bottom of the pit ladder on the pit floor.	Figure 10-1
2	Connect the pit ladder on the well wall.	Figure 10-2

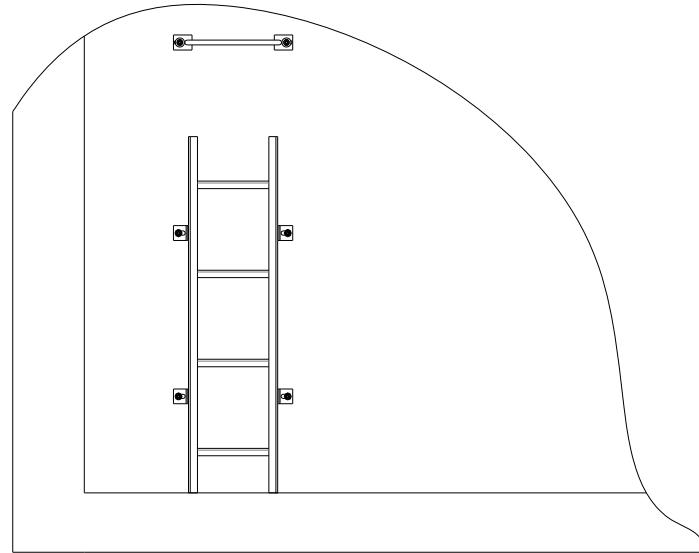

Figure 10-1

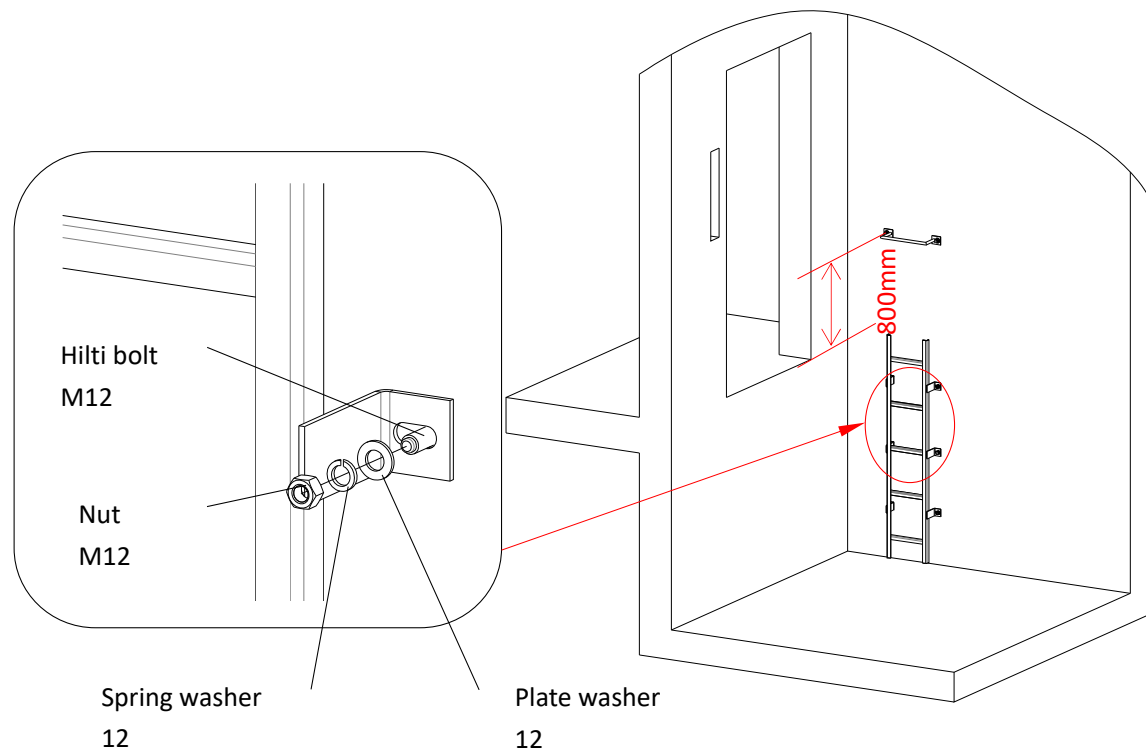

Figure 10-2

## 10.2 Installation of speed governor

Step	Instruction	Fig
1	Connect the speed governor on the machine room floor.	Figure 10-3

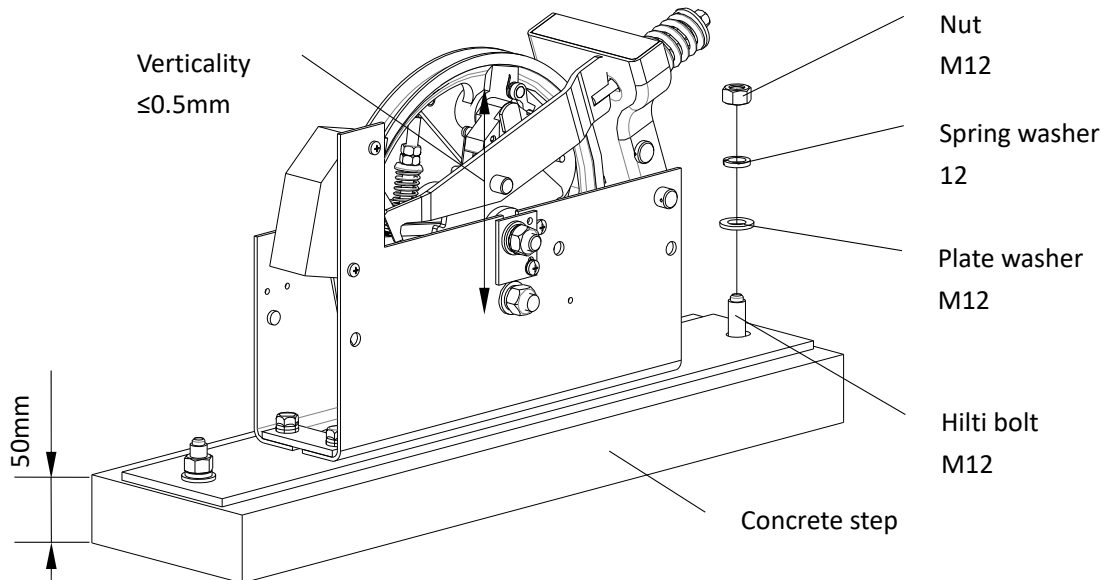

Figure 10-3

### 10.3 Installation of tension device

Step	Instruction	Fig
1	The distance from the bottom of the tension device to the pit floor is 150~250mm.	Figure10-4
2	Connect the plate of tension device on the car rail.	Figure 10-5
3	Connect the weight part of tension device on the plate of tension device.	Figure 10-6
4	Connect the switch on the tension device.	Figure 10-7

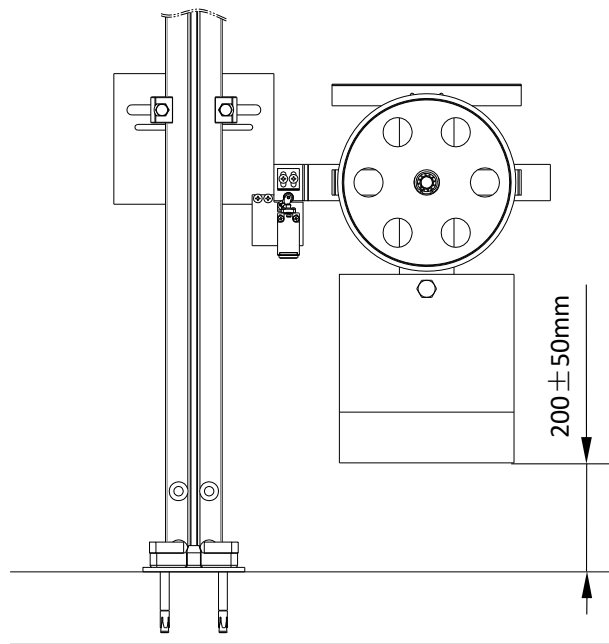

Figure 10-4

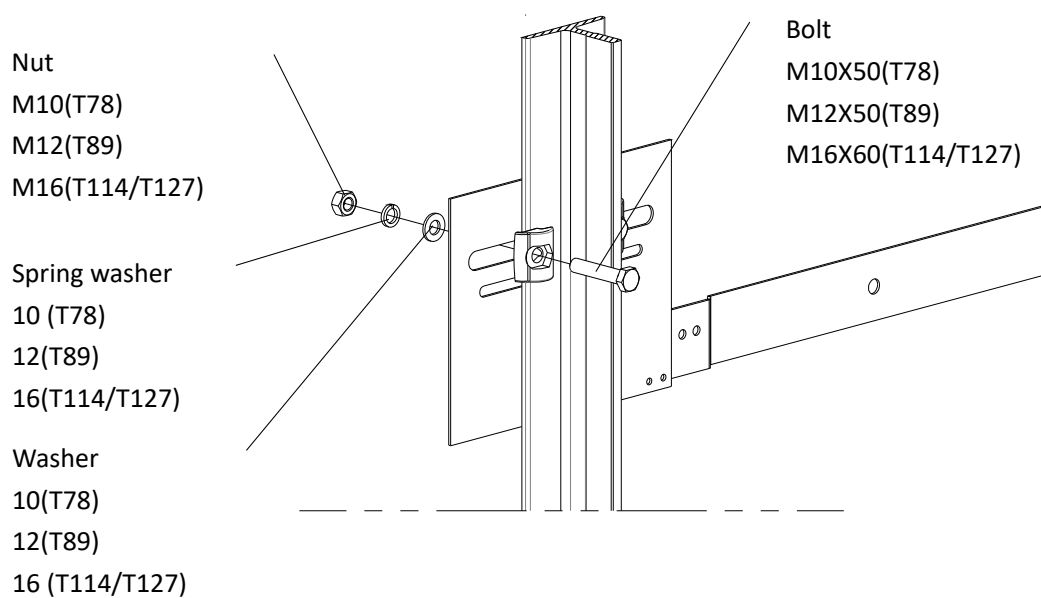

Figure 10-5

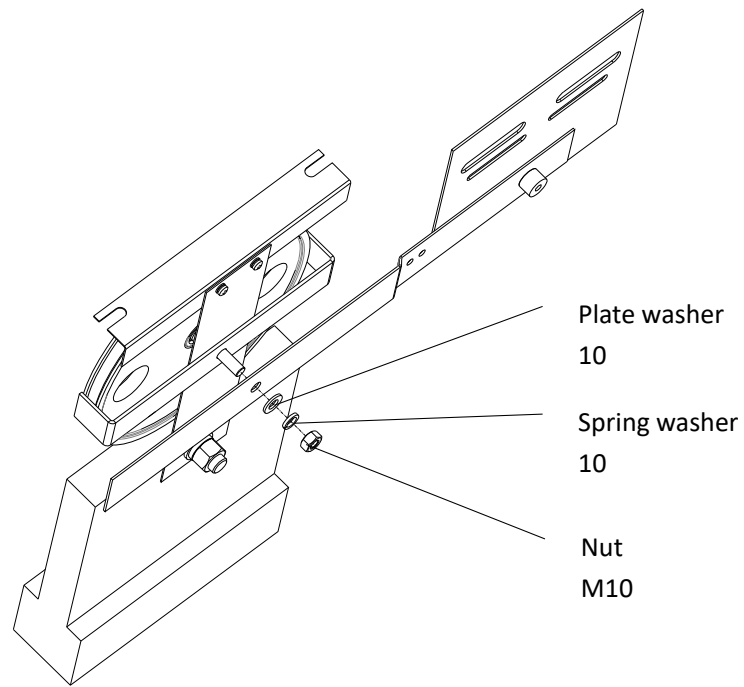

Figure 10-6

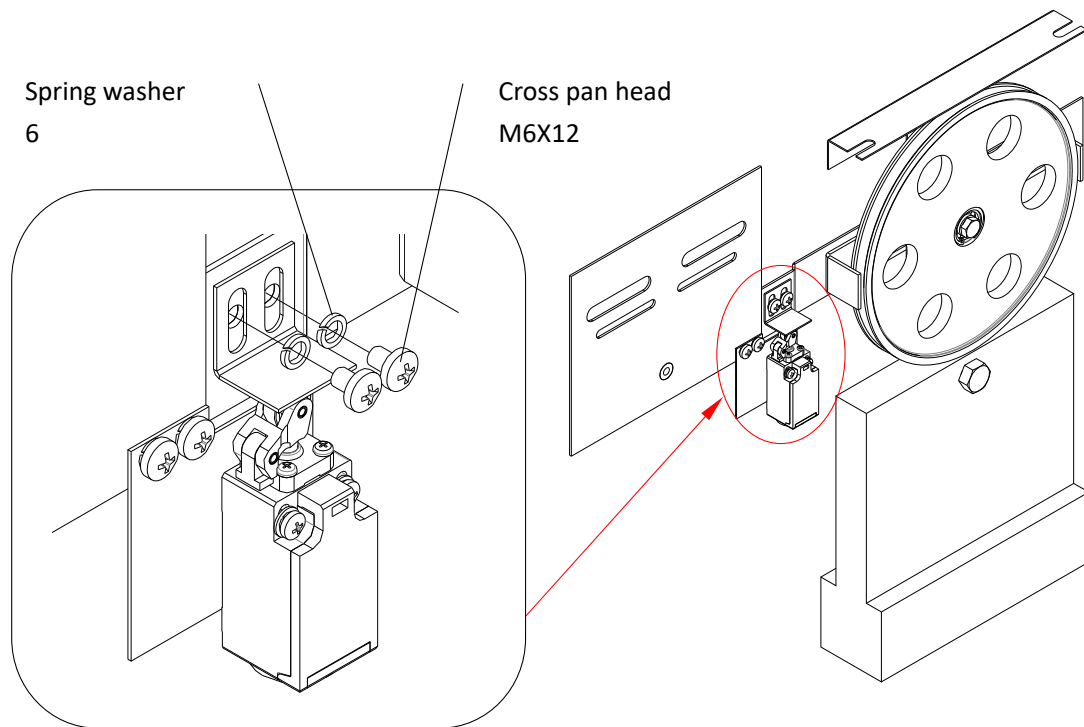

Figure 10-7

## 10.4 Installation of speed governor rope

Step	Instruction	Fig
1	Install the governor rope on governor and tension device, fix the both ends of governor rope to the safety linkage on the car frame by rope clips.	Figure 10-8

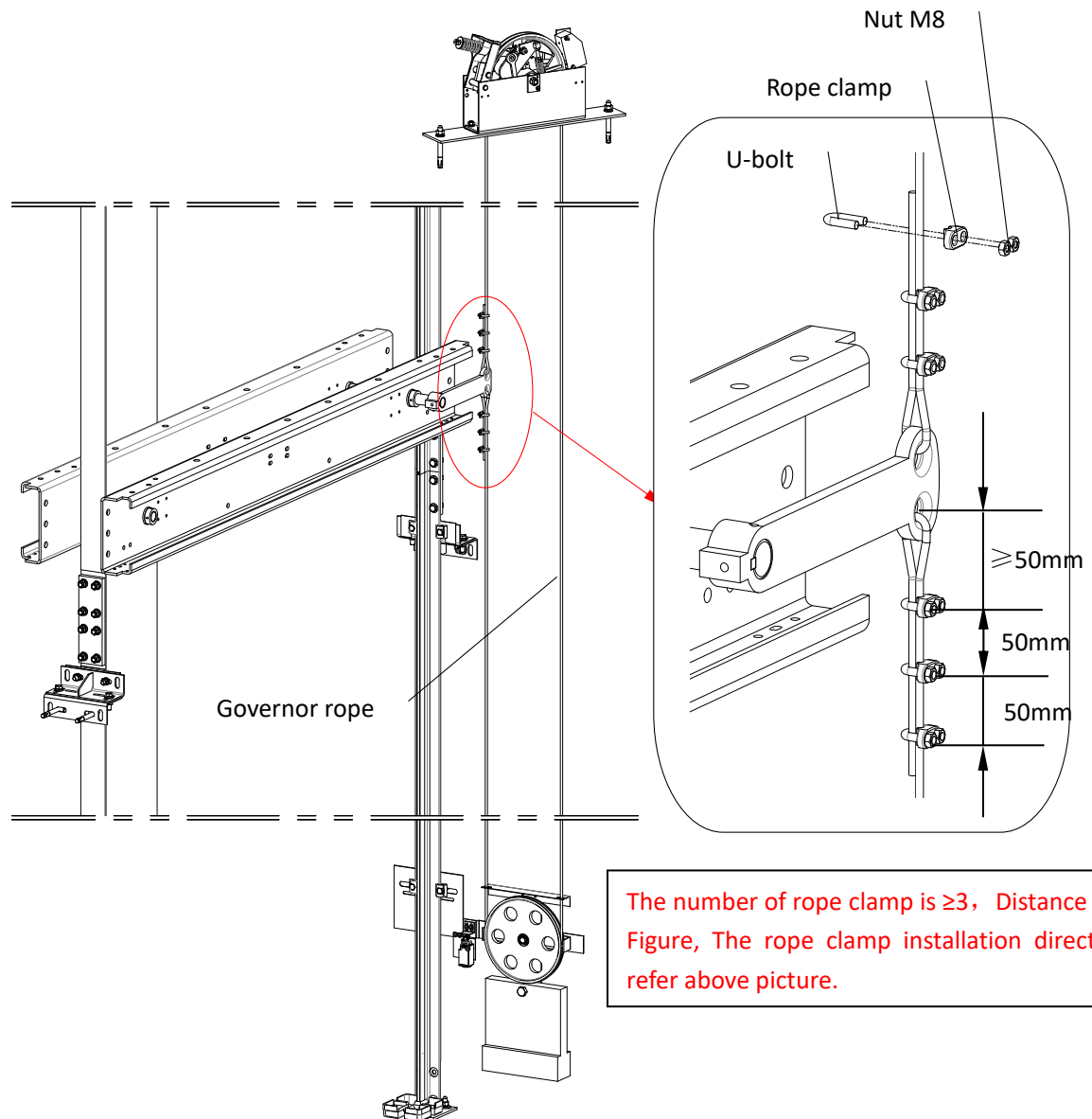

Figure 10-8

### 10.5 Installation of buffer

Step	Instruction	Fig
1	Fix the buffer base on the pit floor.	Figure 10-9
2	Connect the oil buffer on the buffer base.	Figure 10-10
3	Connect the PU buffer base on the pit floor.	Figure 10-11

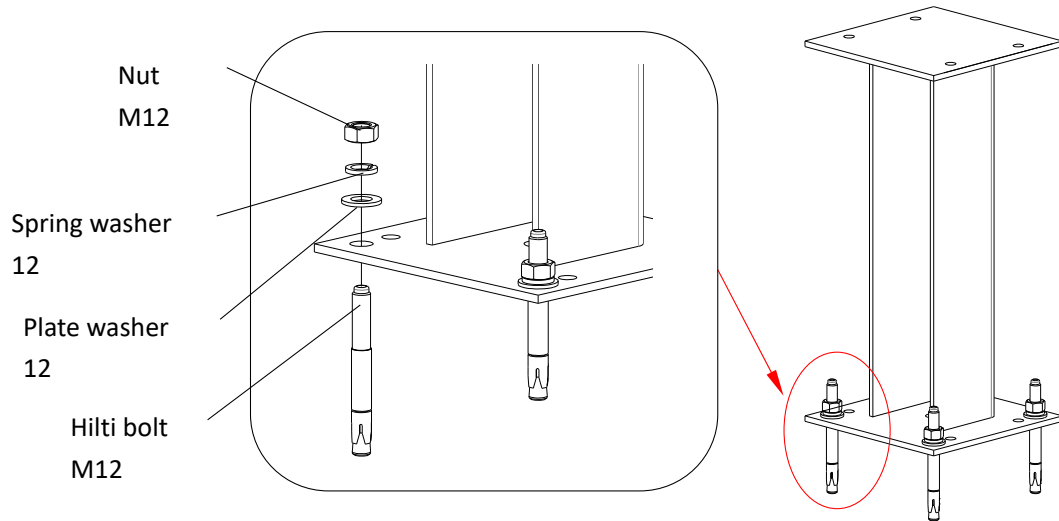

Figure 10-9

#### 10.5.1 Install oil buffer

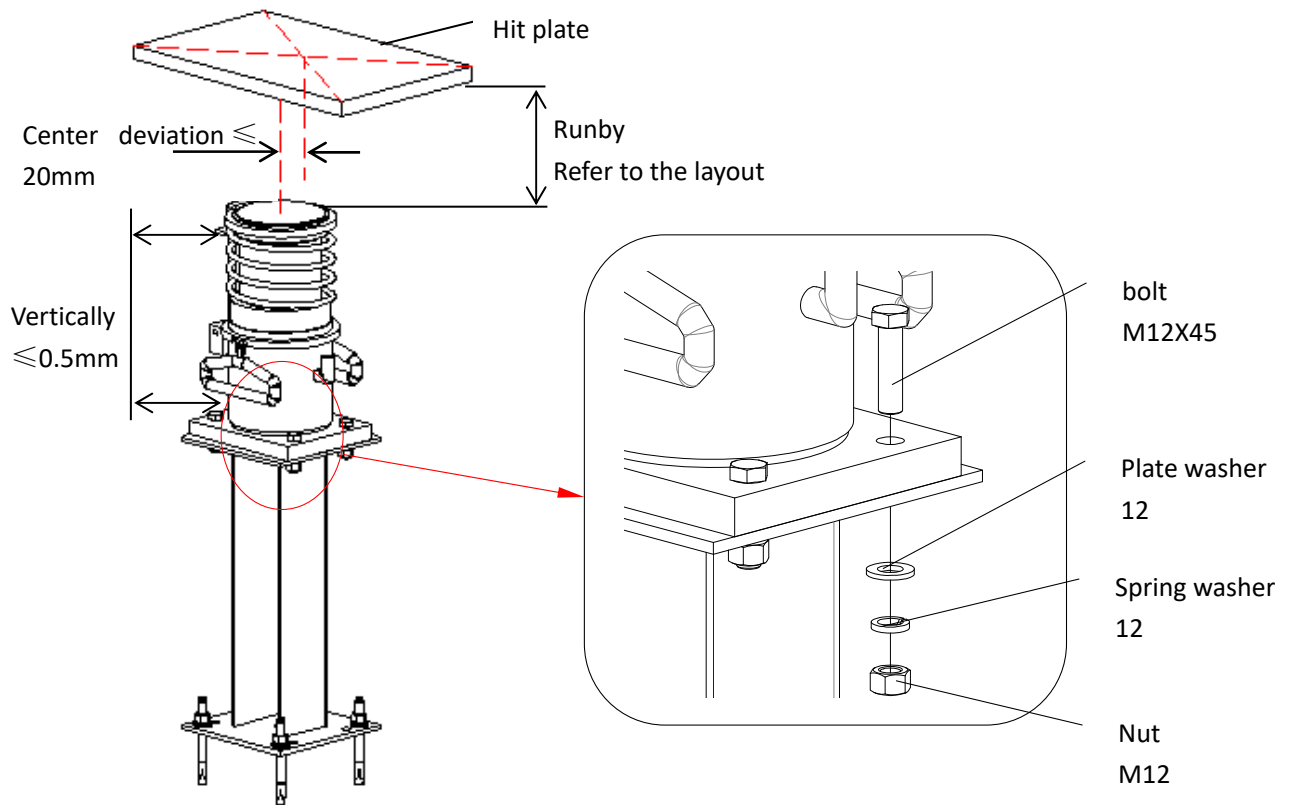

figure 10-10

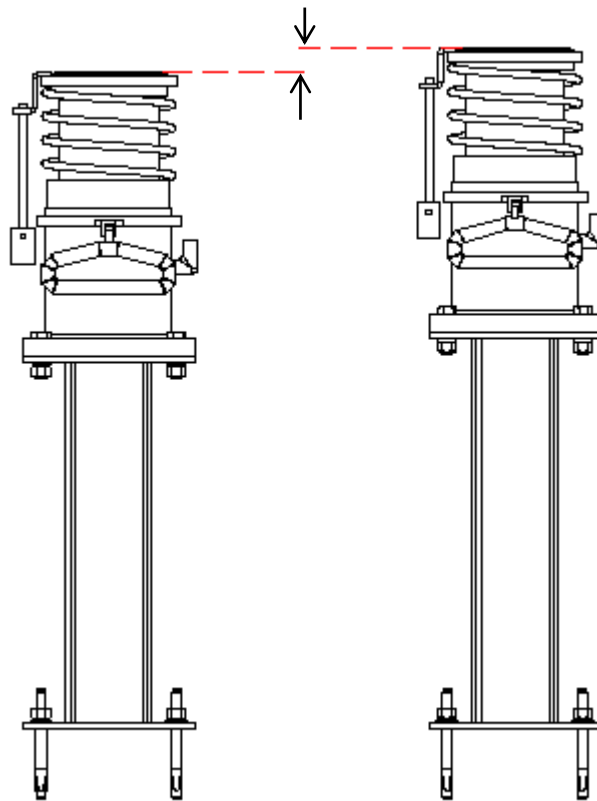

figure10-11

When the number of buffer on the same side  $\geq 2$ ,  
Top height difference  $\leq 2$  mm

### 10.5.2 Install PU buffer

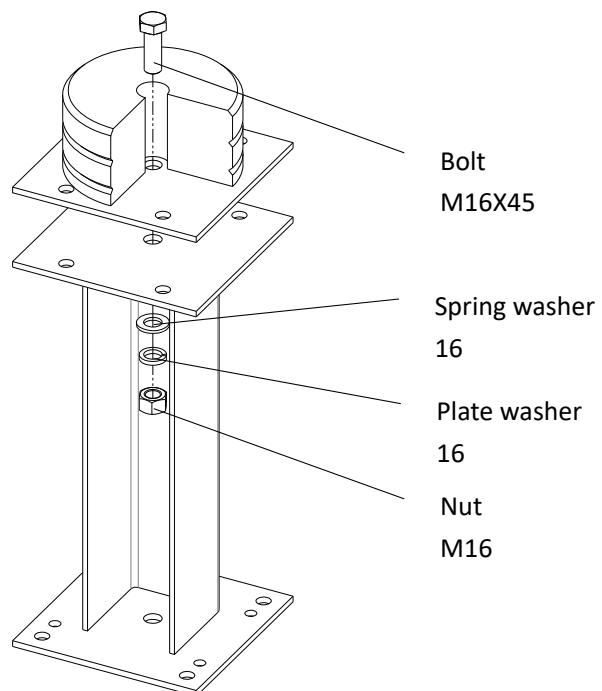



Figure 10-11

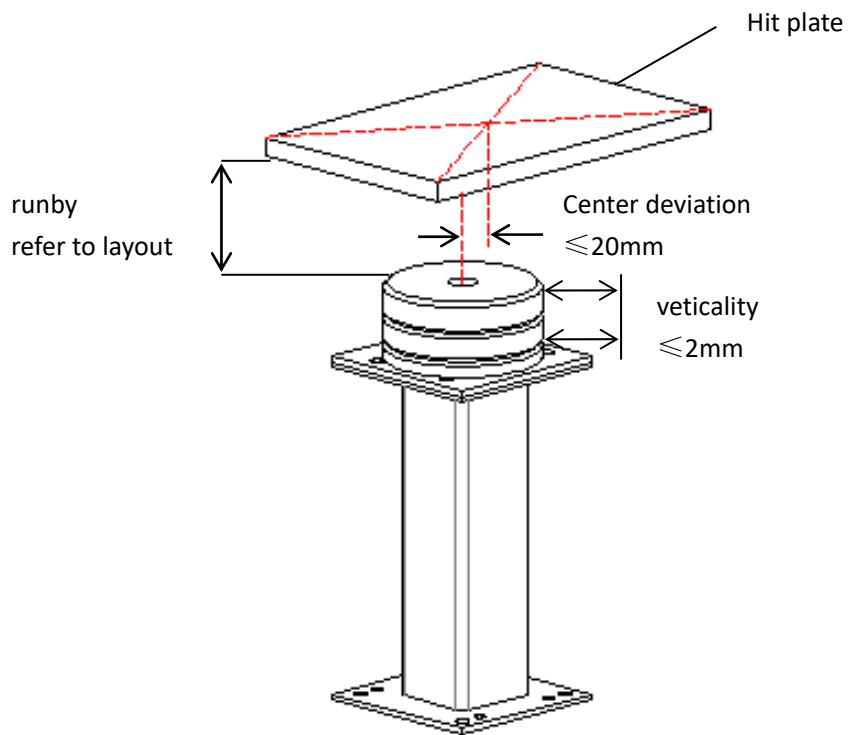
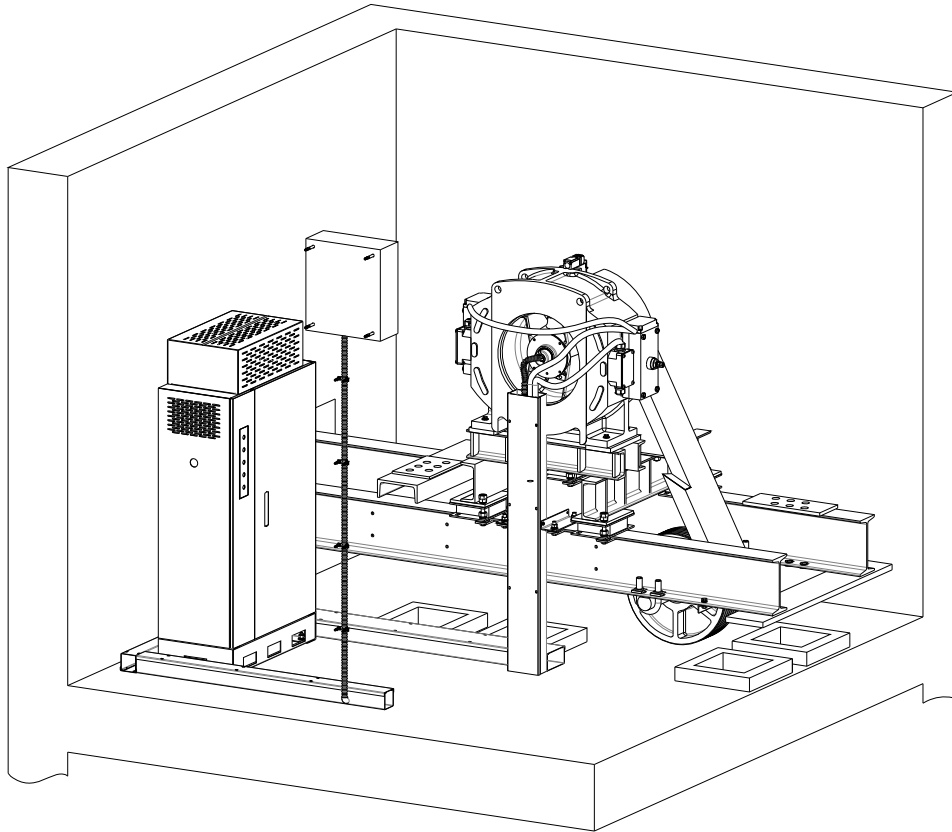

figure10-13

## 11 Installation electrical components in machine room

Electrical components installation overview:



## 11.1 Installation of controller

Step	Instruction	Fig
1	Connect the controller on the machine room floor.	Figure 11-1

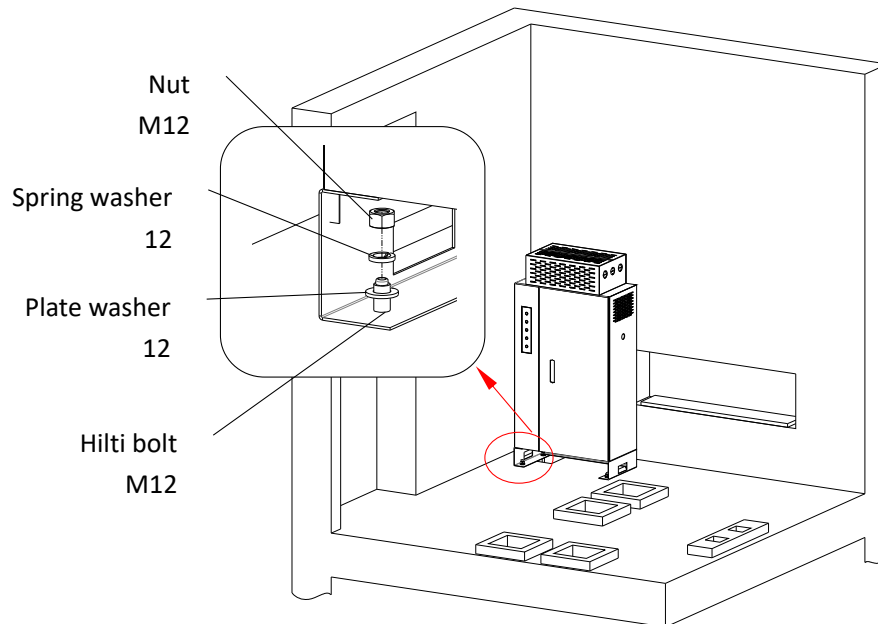

Figure 11-1

The control cabinet location defined in layout drawing. The verticality of the control cabinet  $\leq 3\text{mm}$ .

## 11.2 Installation of receiving box

Step	Instruction	Fig
1	Connect the receiving box on the well wall.	Figure 11-2

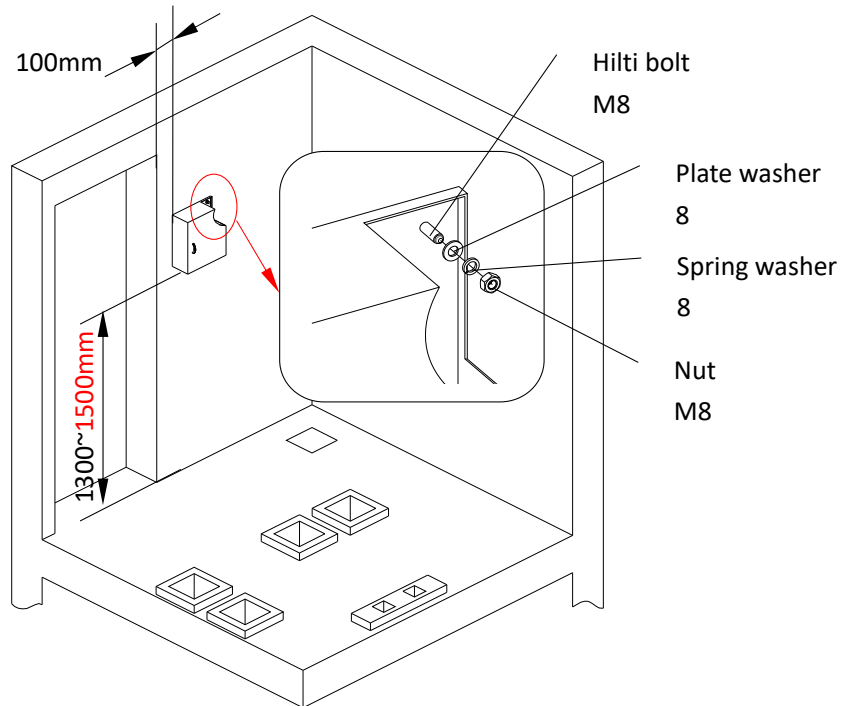

Figure 11-2

### 11.3 Installation of machine room wiring

Step	Instruction	Fig
1	Fix the cable tube on the machine room wall and fix the cable trunking on the machine room floor.	Figure 11-3
2	Connect the cover on the cable trunking.	Figure 11-4

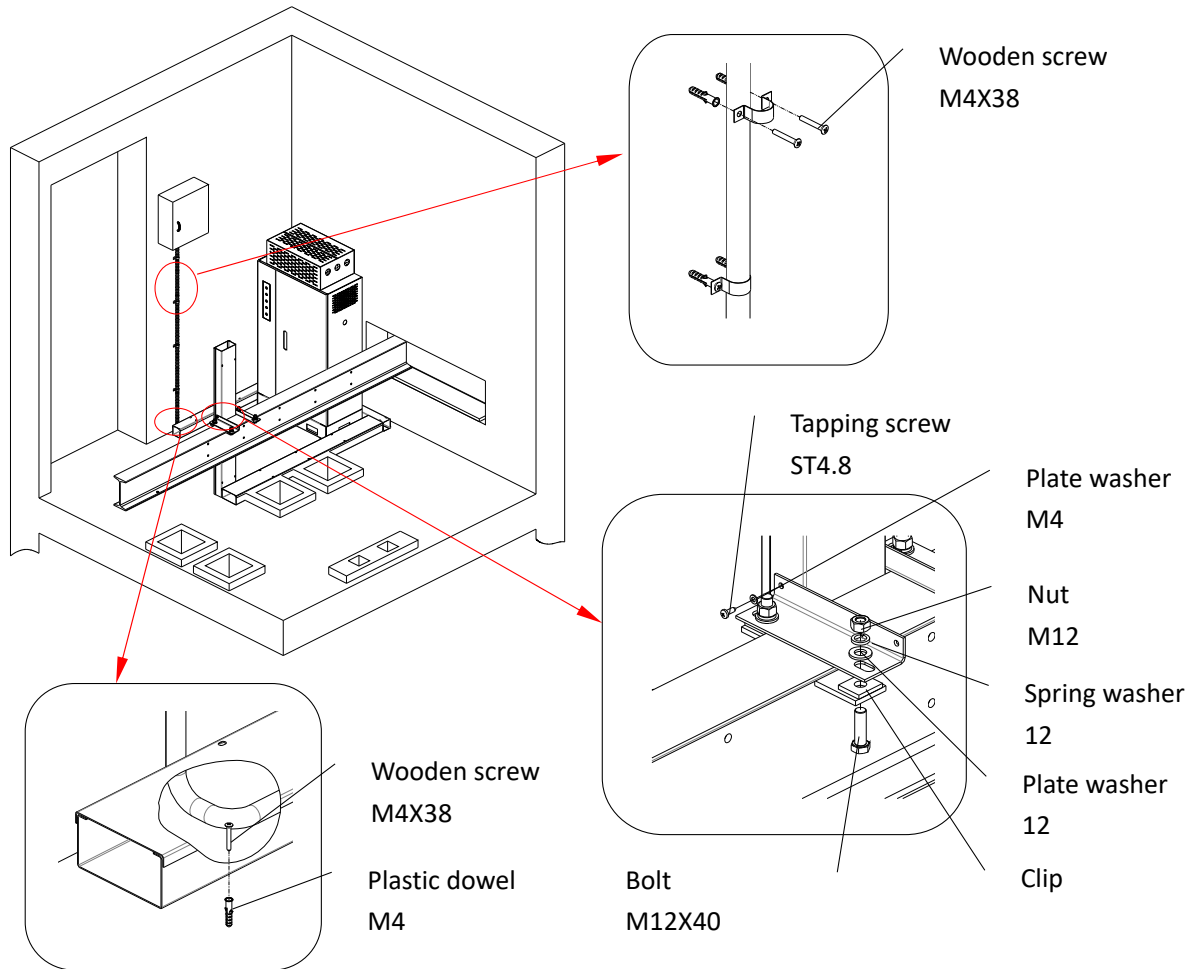

Figure 11-3

**Trunking installation requirements:**

- 1) Smooth vertical and horizontal, Trunking must be grounding;
- 2) Corner shall prevented by liner to protect wiring;.

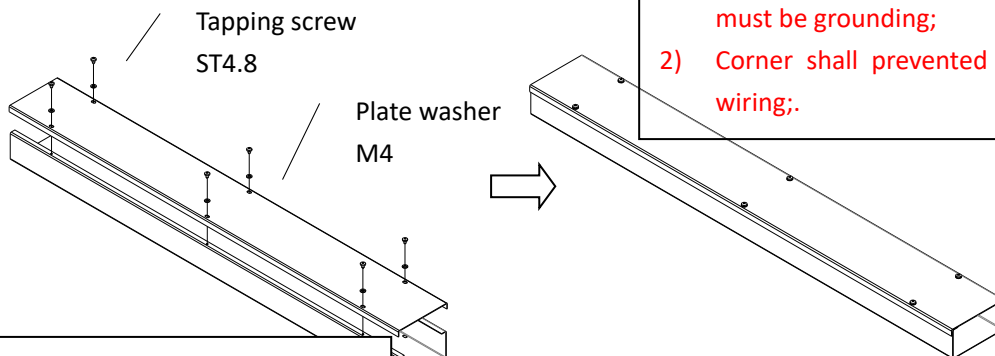

Figure 11-4

3) The cable trunking at least two fixed points, wiring at sharp edge shall be protected.

---

**11.4 Install hand wheel**

step	instruction	fig
1	Install hand wheel on the wall	figure 11-1

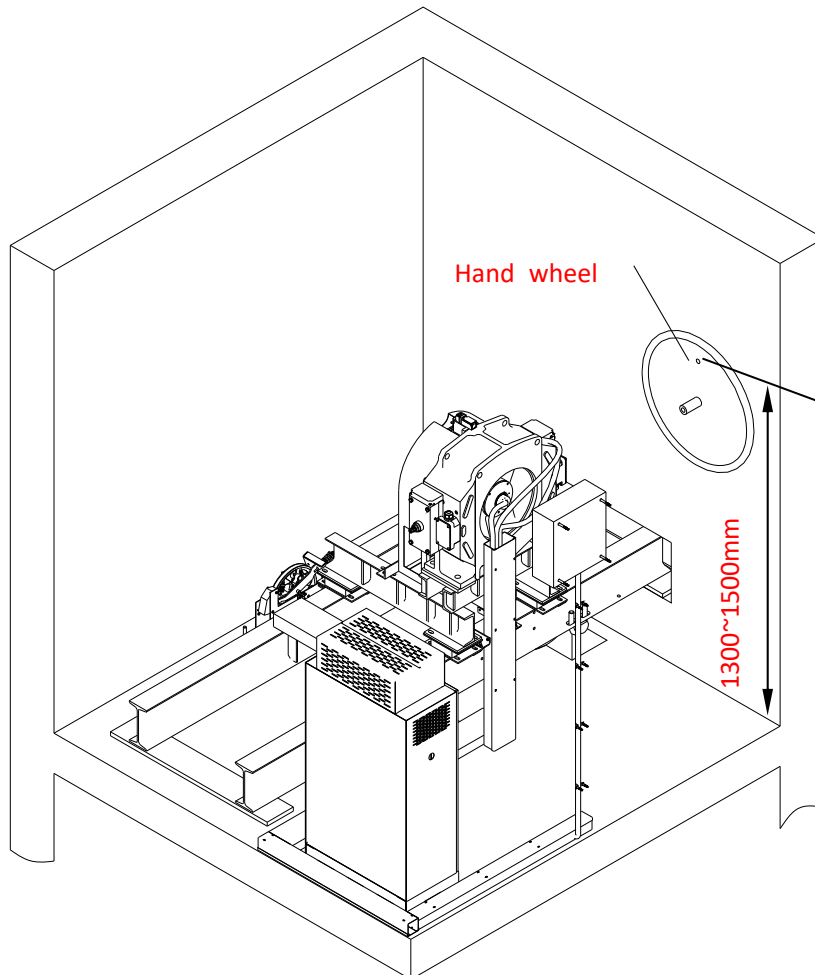

**Note:** Hand wheel mounted on the wall is easy to pick up in the machine room

## 12 Installation of compensation chain

Step	Instruction	Fig
1	Connect the compensation chain under car sub-frame and counterweight frame.	Figure 12-1
2	Install chain guide of compensation	Figure 12-2

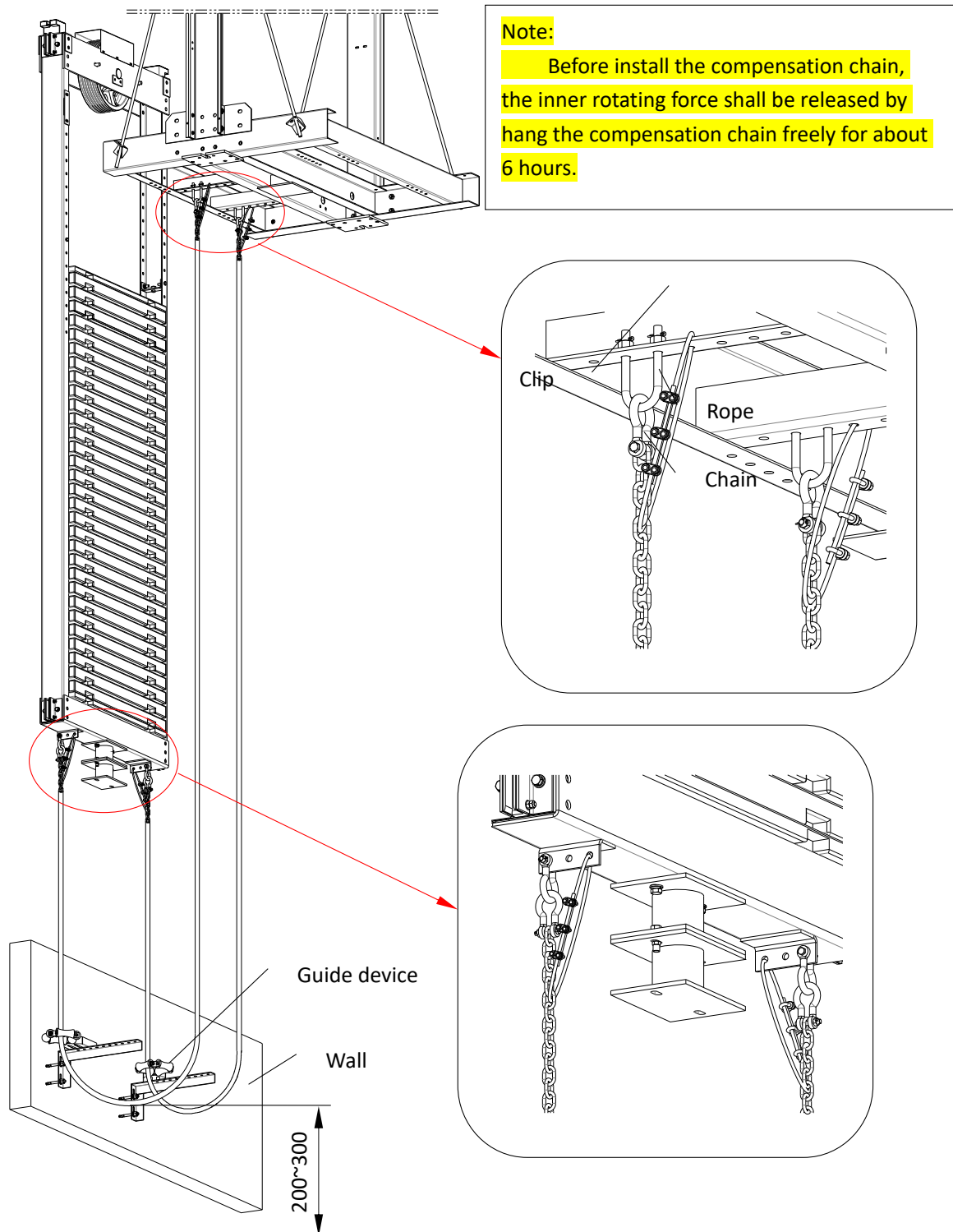

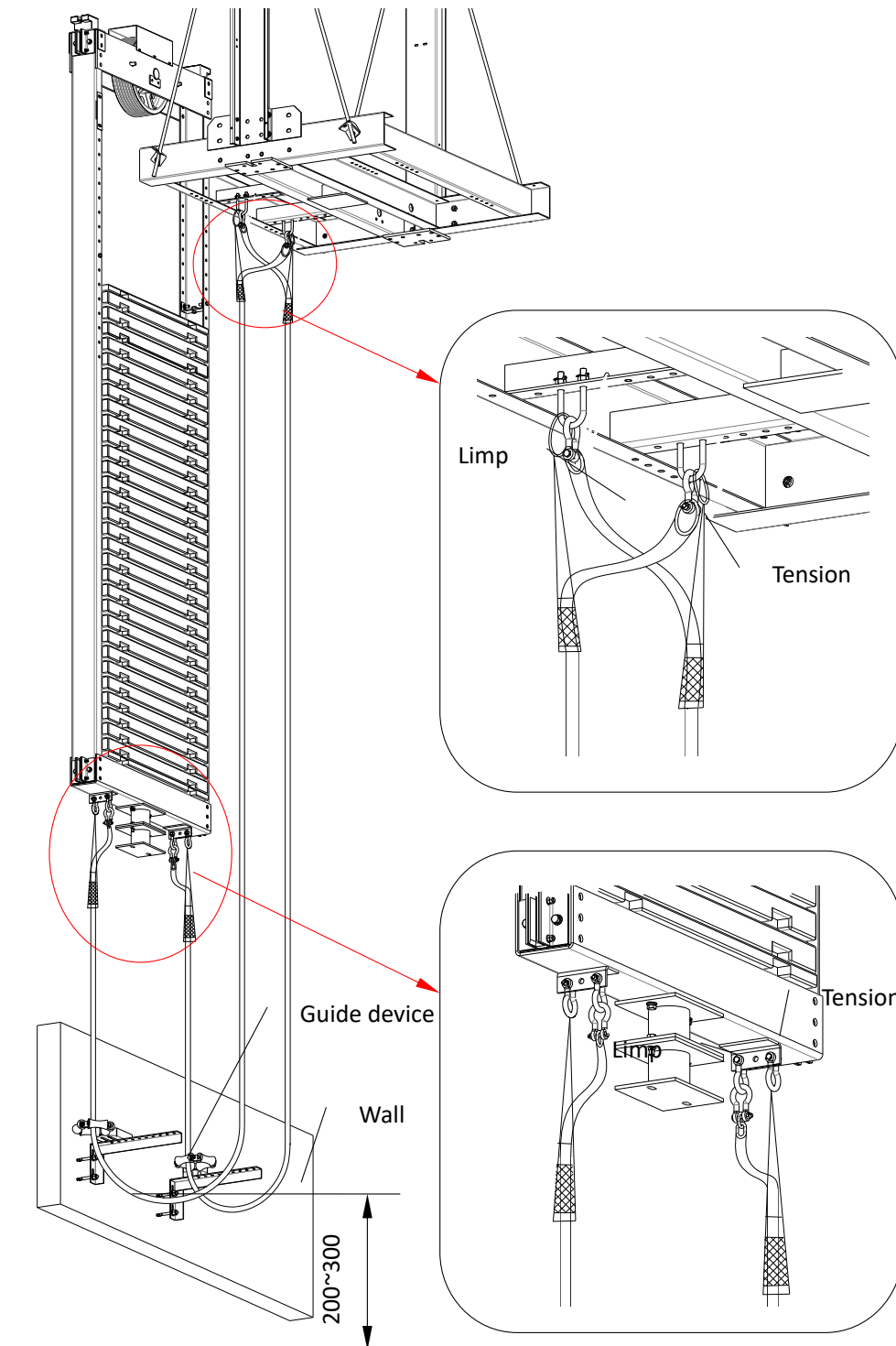

Figure 12-1



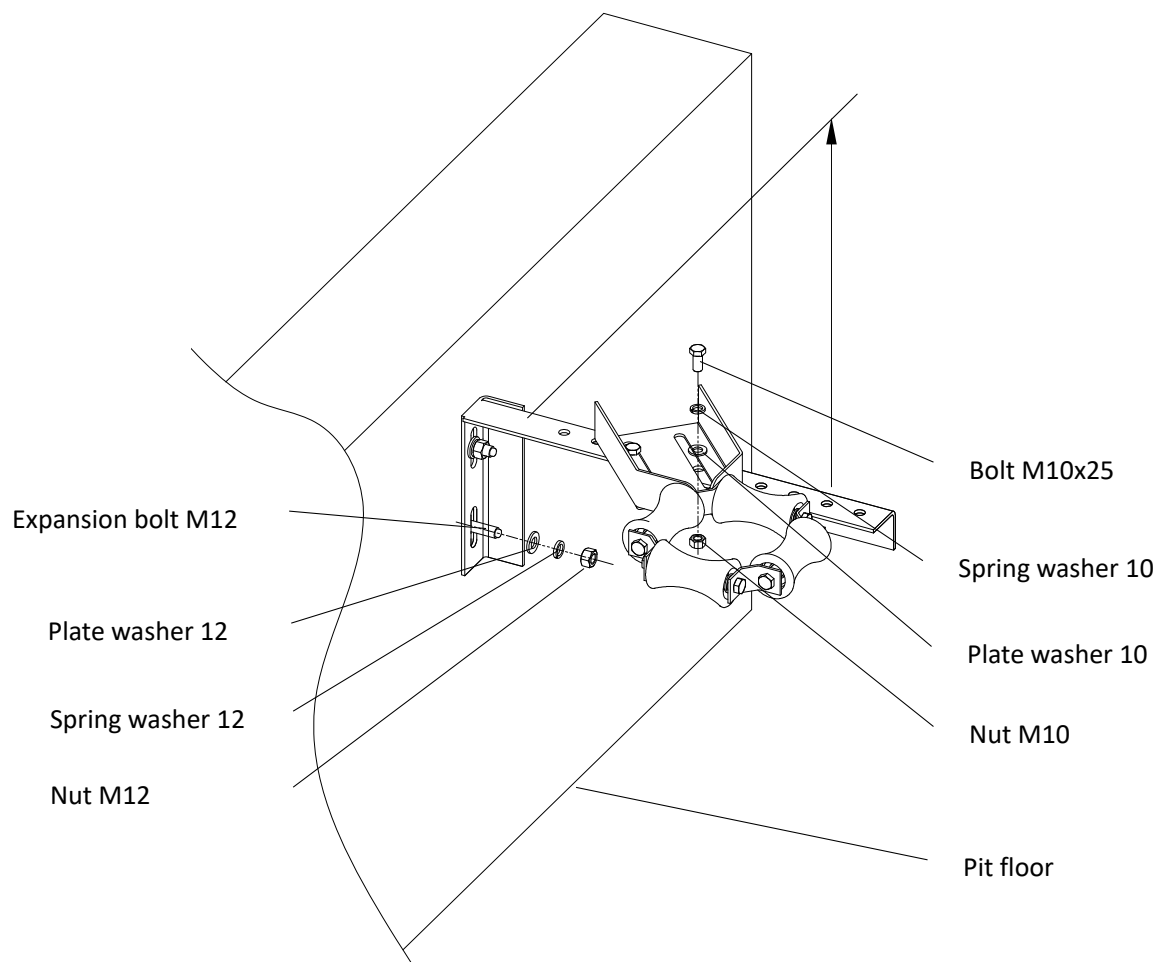

Figure 12-2

Part number	model	Chain ring diameter $\phi$	Bending diameter $\phi$
SDA280A2	WFC075	7.0±0.5mm	280±50mm
SDA280A3	WFC100	8.0±0.5mm	300±50mm
SDA280A4	WFC125	9.0±0.5mm	300±50mm
SDA280A5	WFC150	10.0±0.5mm	300±50mm
SDA280A6	WFC200	11.0±0.5mm	300±50mm
SDA280B3	QL125	7.0±0.5mm	610±50mm
SDA280B4	QL150	7.5±0.5mm	610±50mm
SDA280B5	QL200	8.5±0.5mm	660±50mm

**Note:**

When install the compensation chain guider, the center of guider shall align with compensation chain center.

## 13 Installation of cab

Cab installation overall picture:

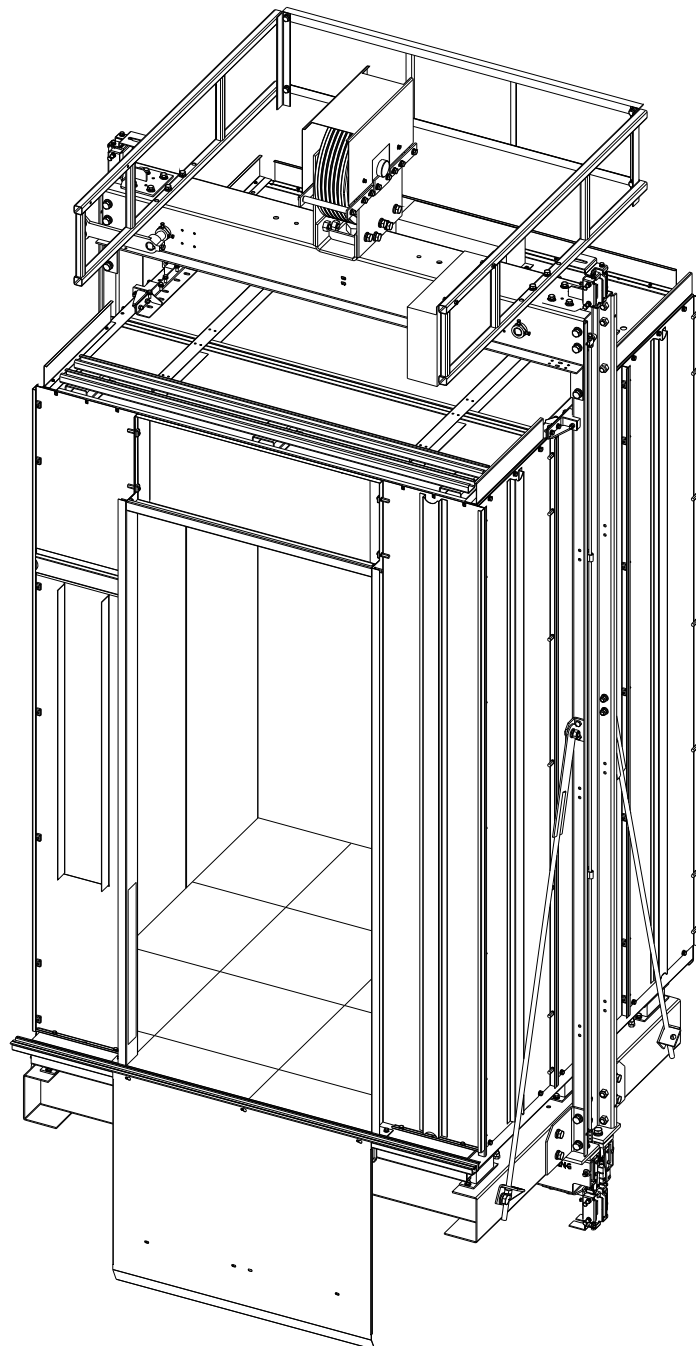

### 13.1 Installation of car panel

Step	Instruction	Fig
1	Install the panels on the platform according sequence.	Figure 13-1
2	Install the first and second panels on the platform.	Figure 13-2
3	Install other side and rear panels on the platform with the same way.	Figure 13-3

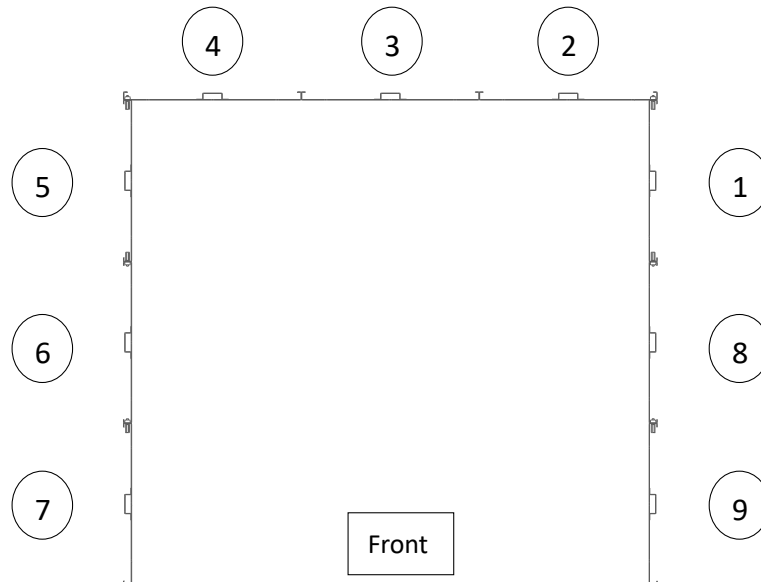

Figure 13-1

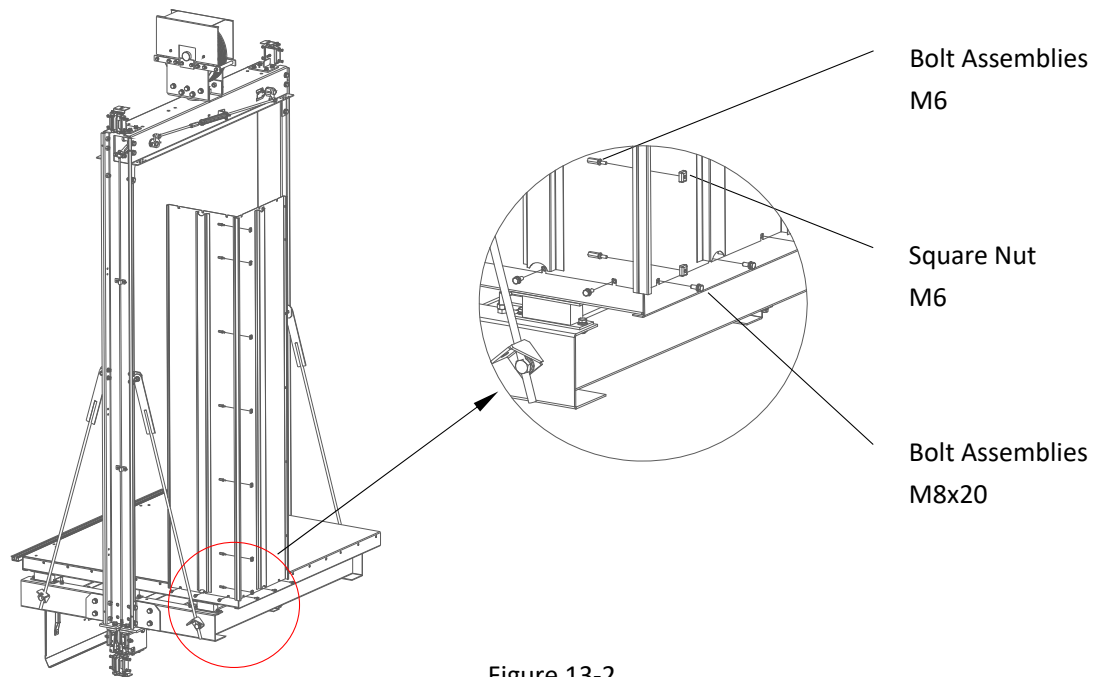

Figure 13-2

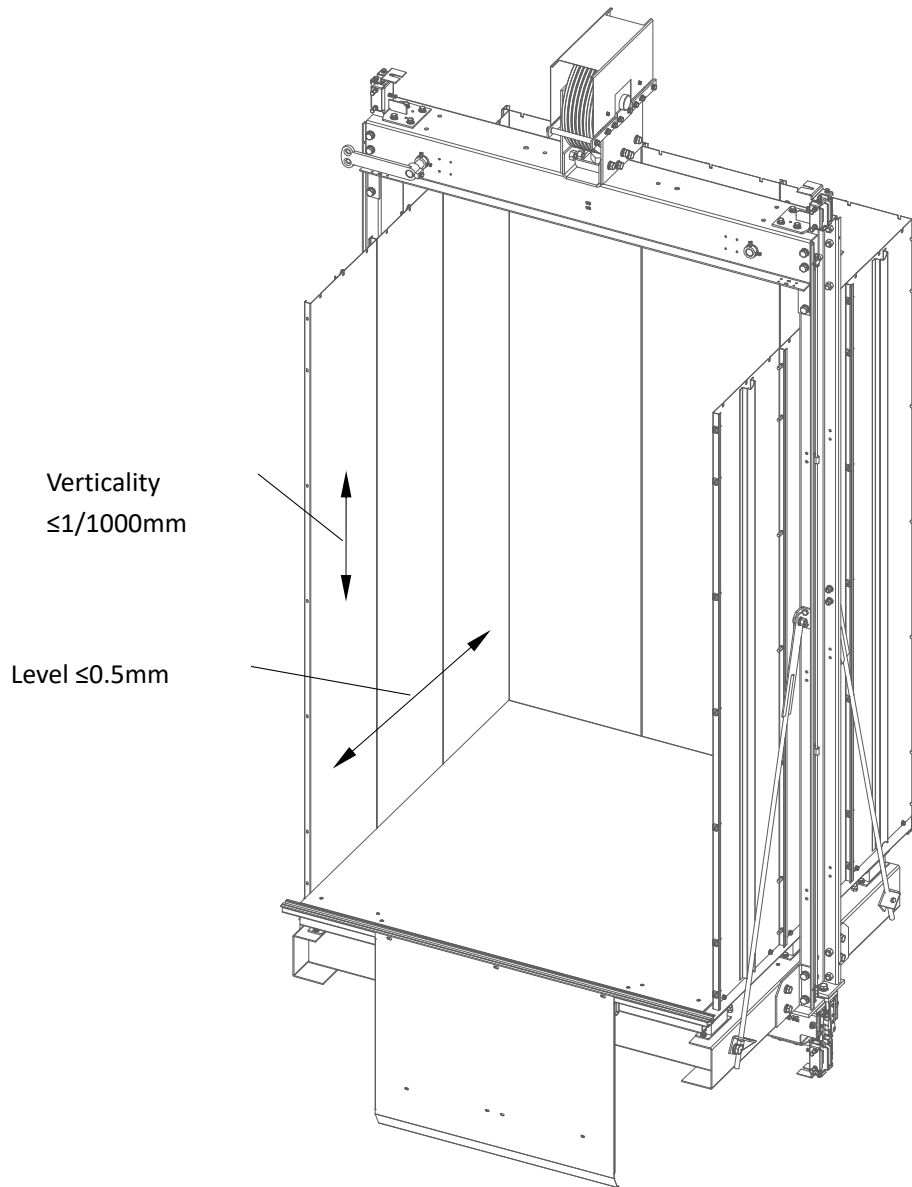

Figure 13-3

### 13.2 Installation of car ceiling

Step	Instruction	Fig
1	Install the car ceiling on the wall panels.	Figure 13-4
2	Install the front panels.	Figure 13-5
3	Install the cab steadiers on the ceiling.	Figure 13-6

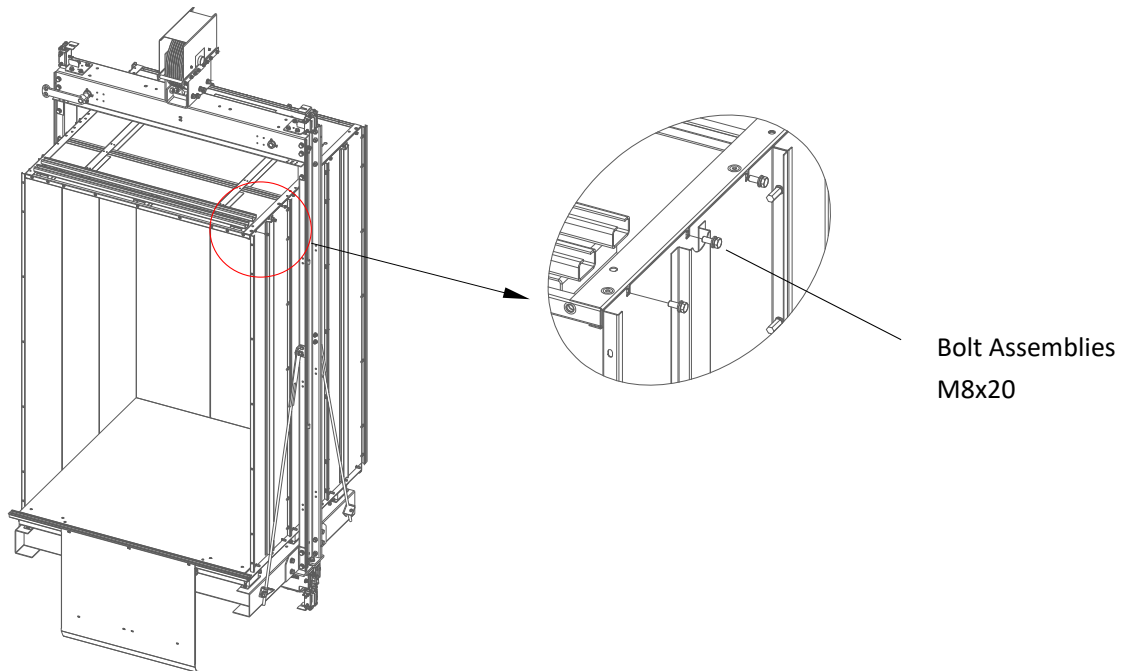

Figure 13-4

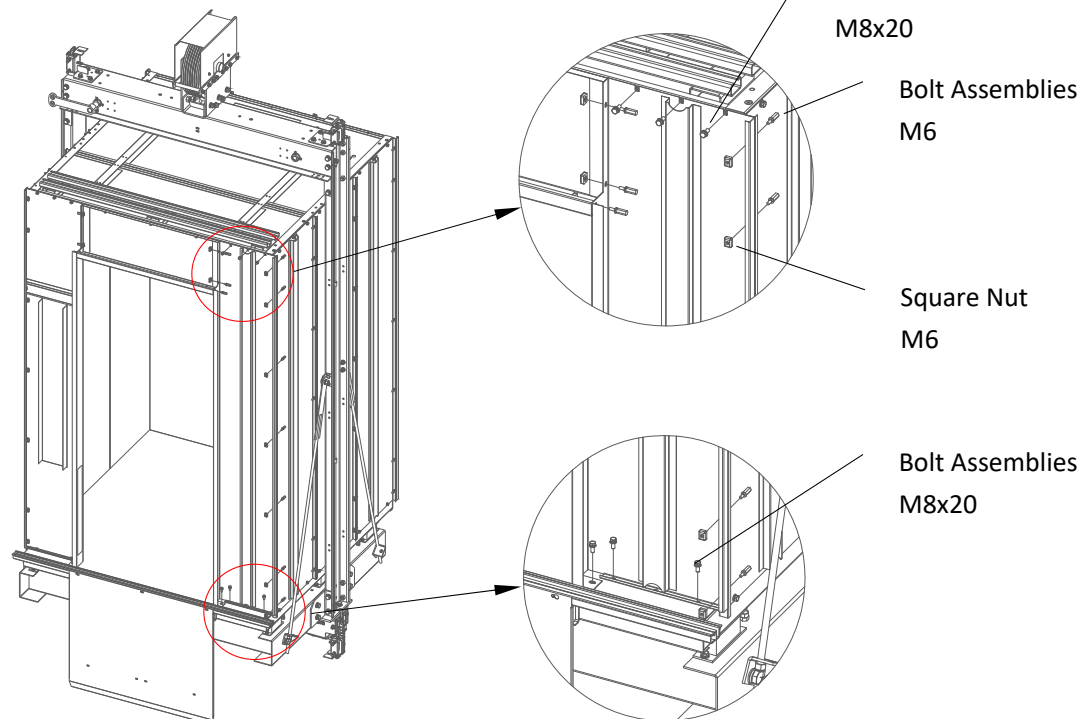

Figure 13-5

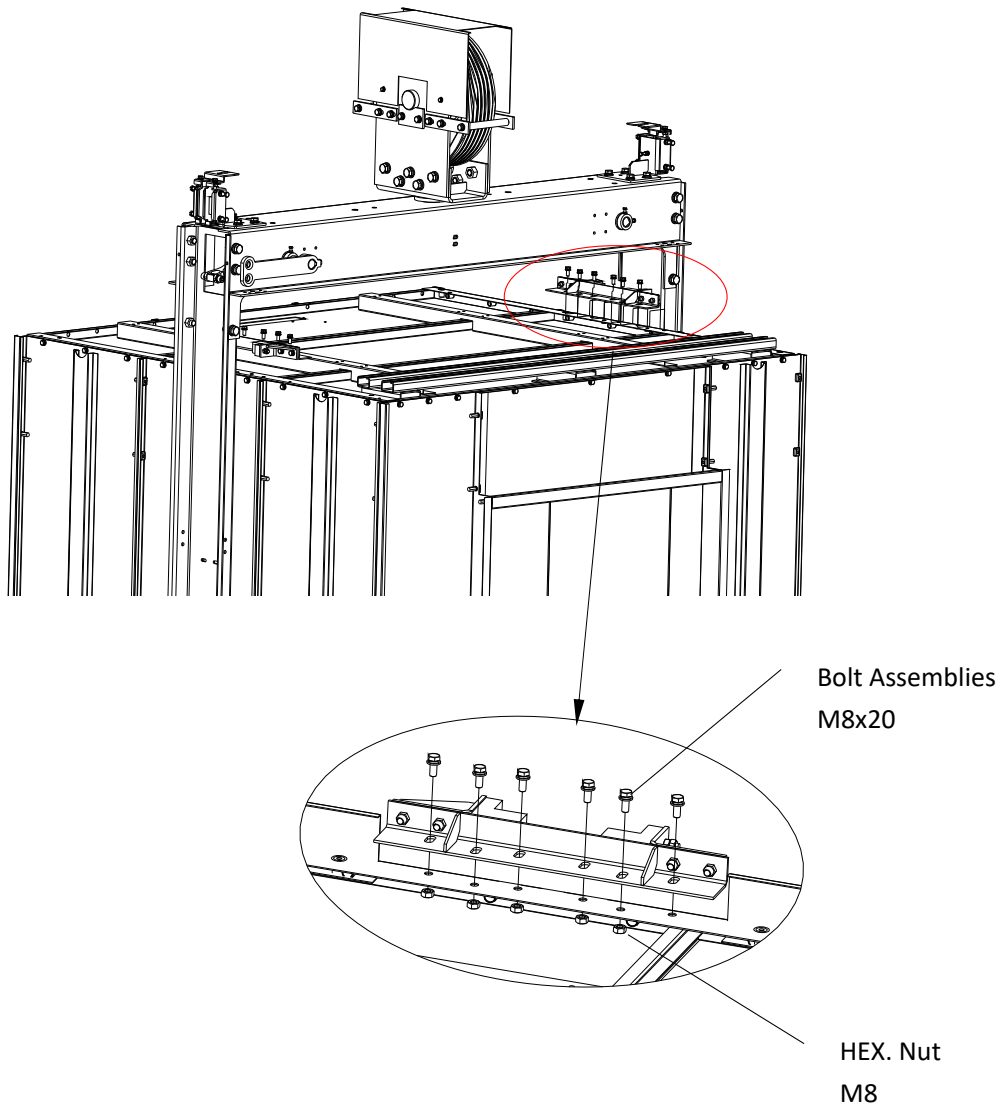

Figure 13-6

### 13.3 Installation of TOC handrail

Step	Instruction	Fig
1	Connect the both side TOC handrail to the crosshead.	Figure 13-7
2	Connect the back side handrail to the side handrail.	Figure 13-8

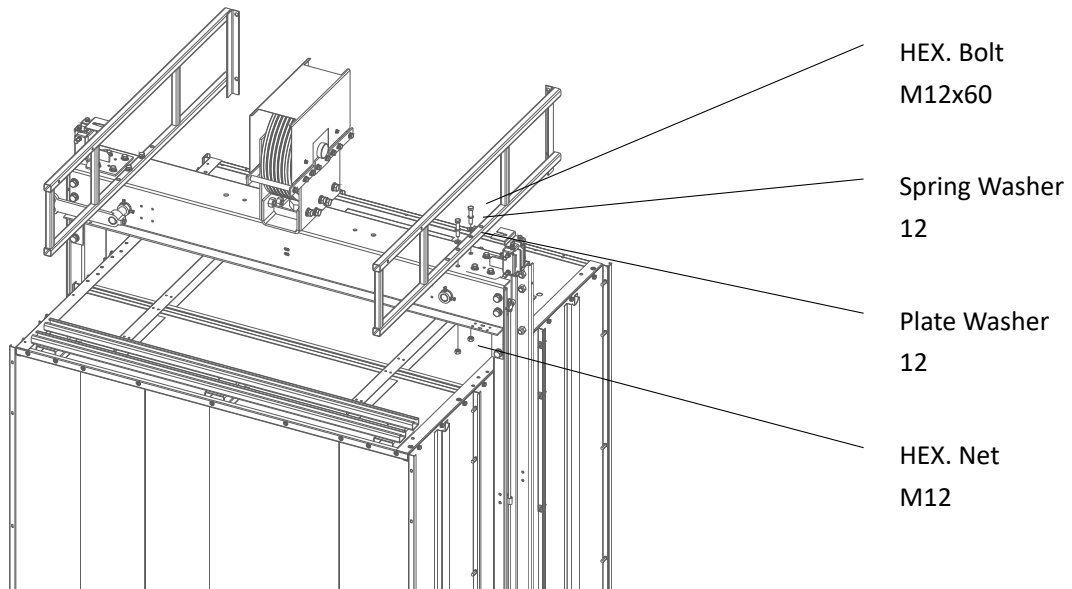

Figure 13-7

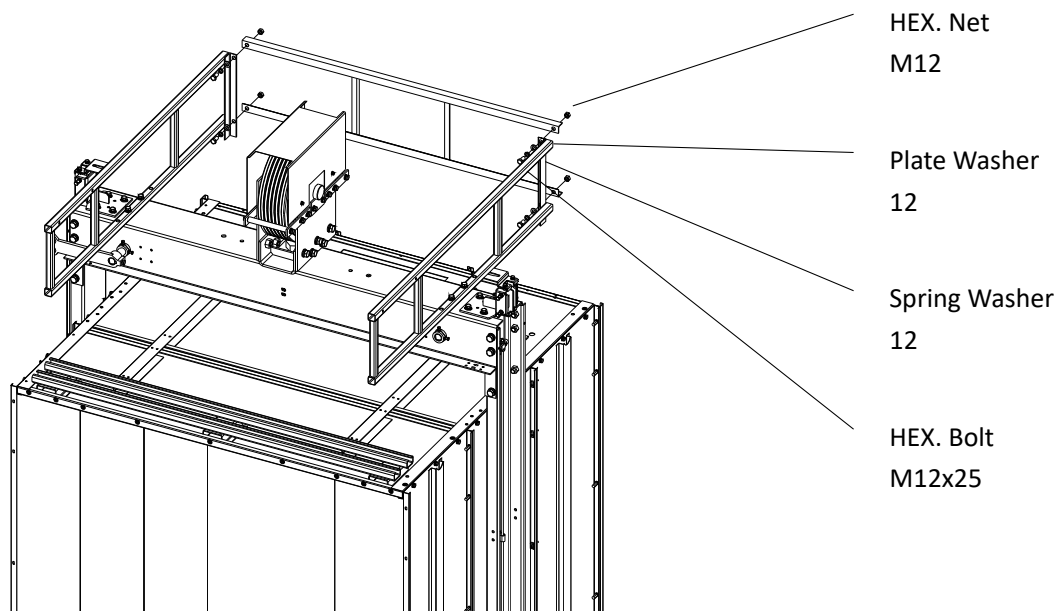

Figure 13-8

---

**13.4 Installation of car fan**

Step	Instruction	Fig
1	Connect the car fan to the ceiling.	Figure 13-9

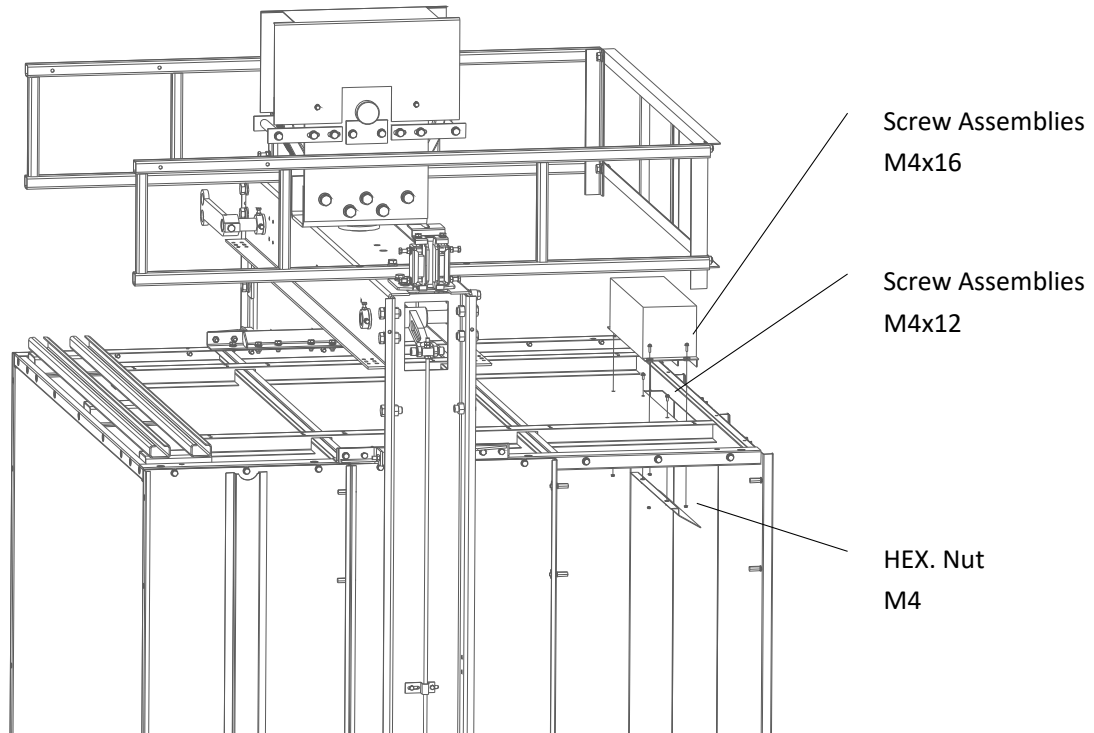

Figure 13-9



### 13.5 Installation of TOC junction box

Step	Instruction	Fig
1	Connect the junction box to the handrail.	Figure 13-10

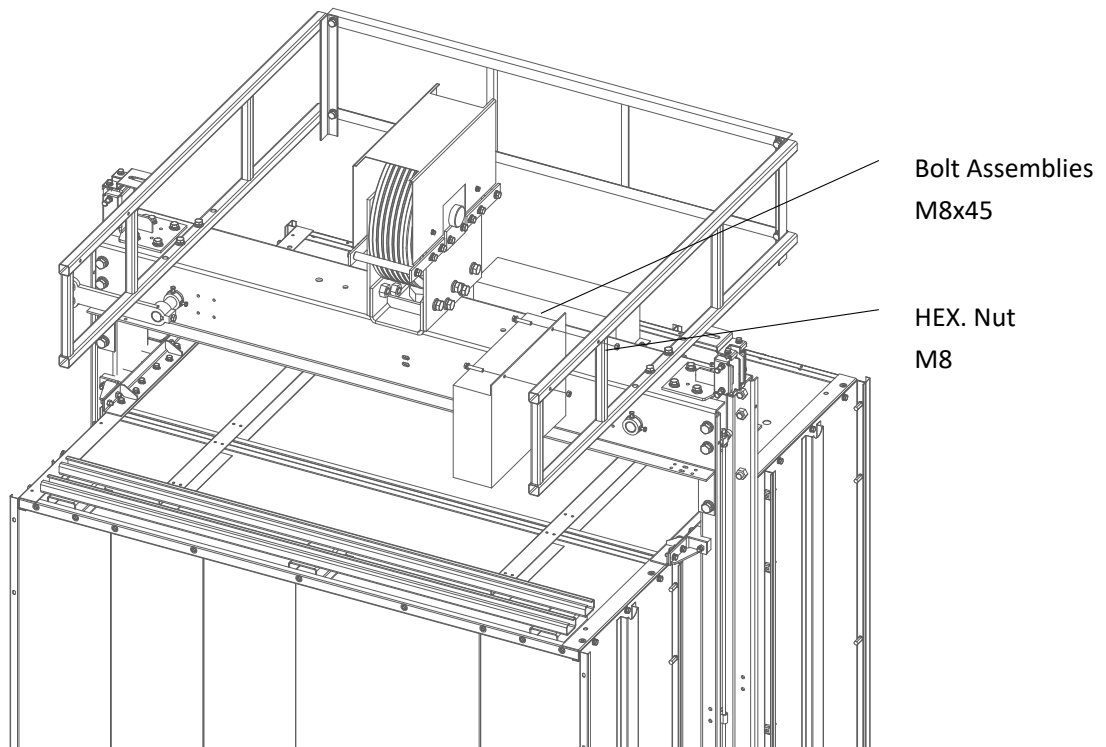

Figure 13-10

---

**13.6 Installation of toe guard**

Step	Instruction	Fig
1	Connect the toe guards on the car ceiling.	Figure 13-11

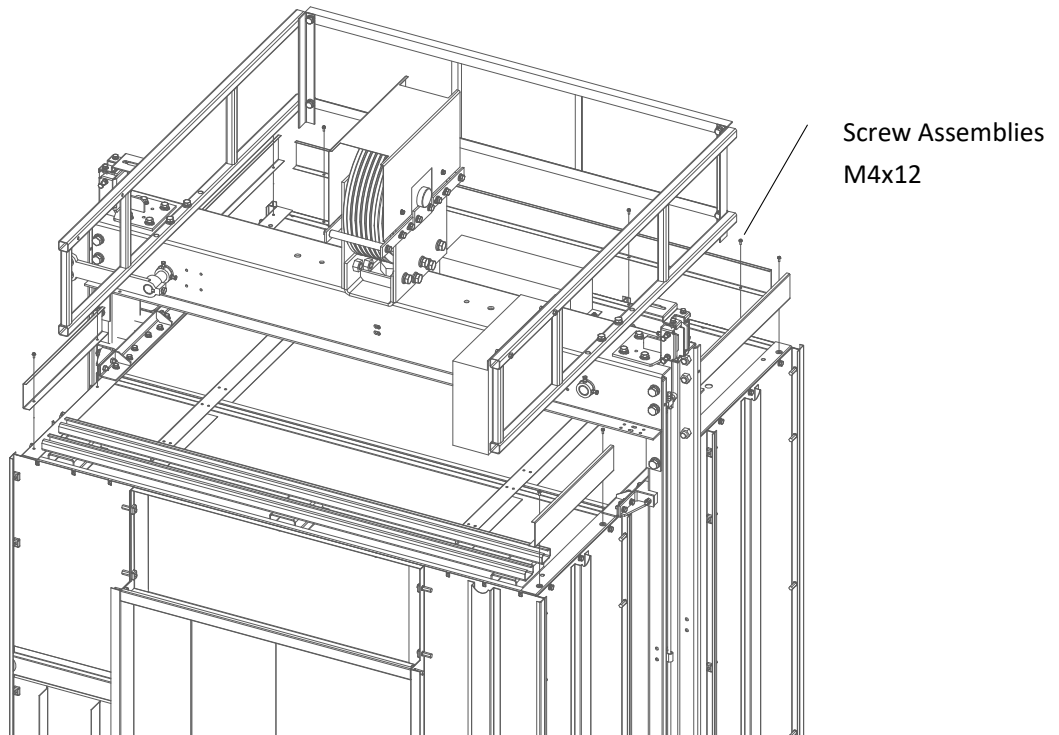

Figure 13-11

---

**13.7 Installation of car floor**

Step	Instruction	Fig
1	Glue the PVC floor on the platform.	Figure 13-12, 13-13

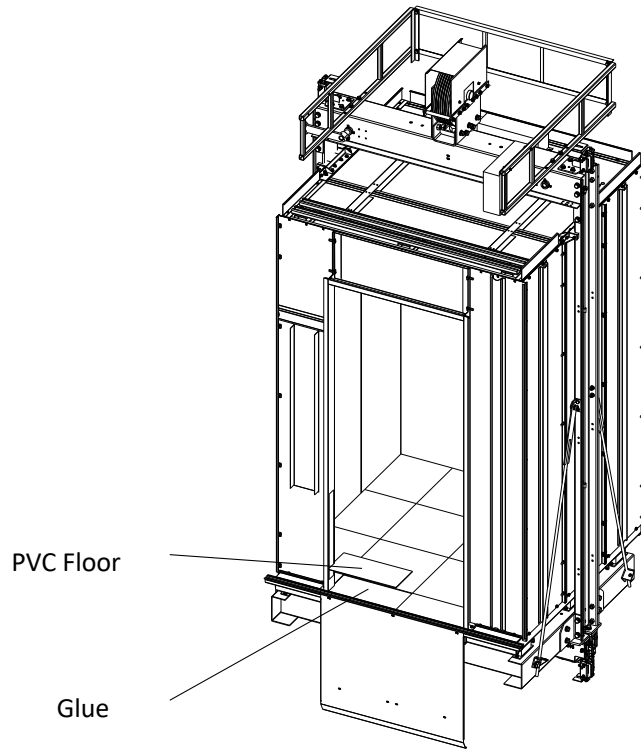

Figure 13-12

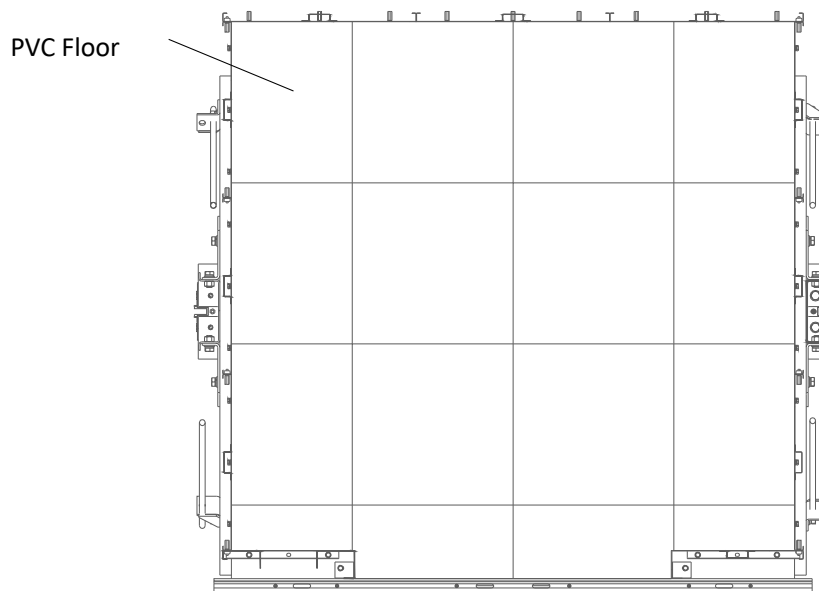

Figure 13-13

---

**13.8 Installation of load weighing device**

Step	Instruction	Fig
1	Connect the bolt assembly at bottom of platform.	Figure 13-14
2	Fix the load sensor on sub-frame.	Figure 13-14

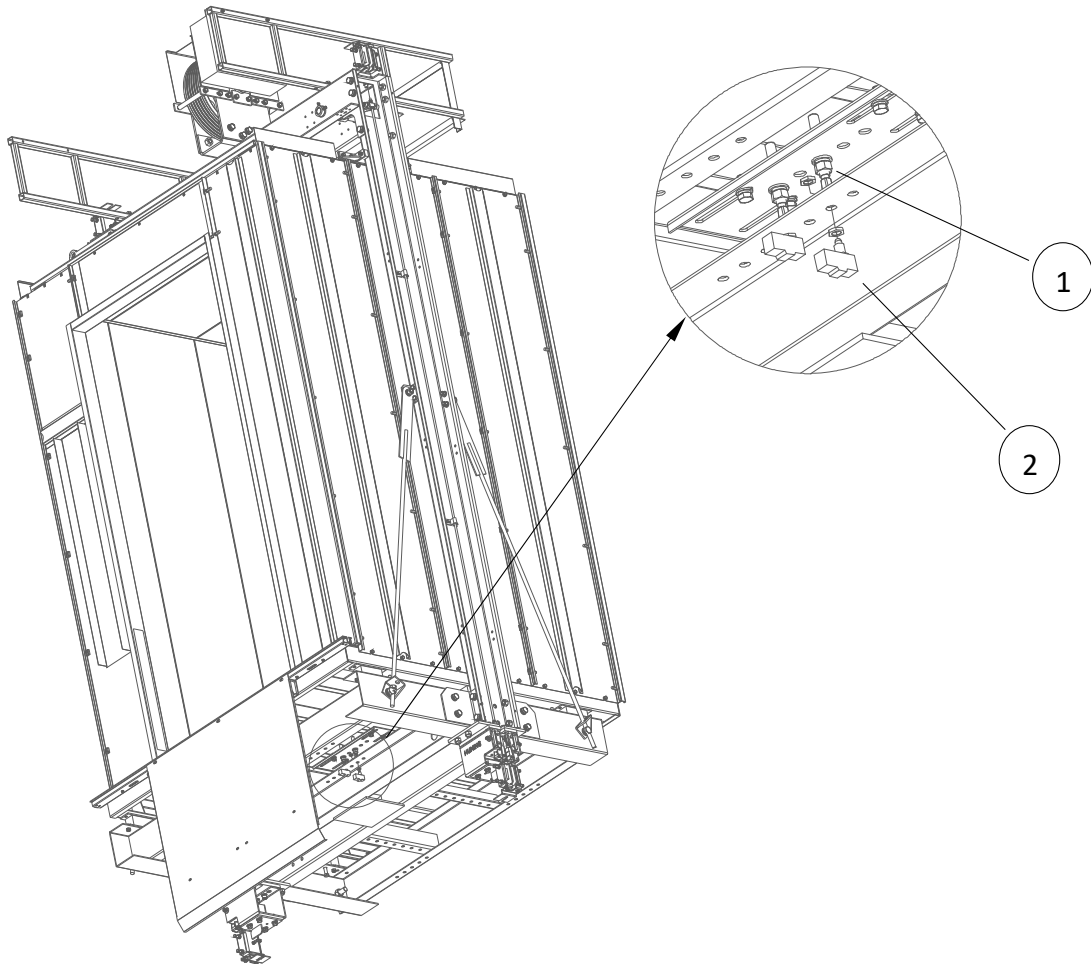
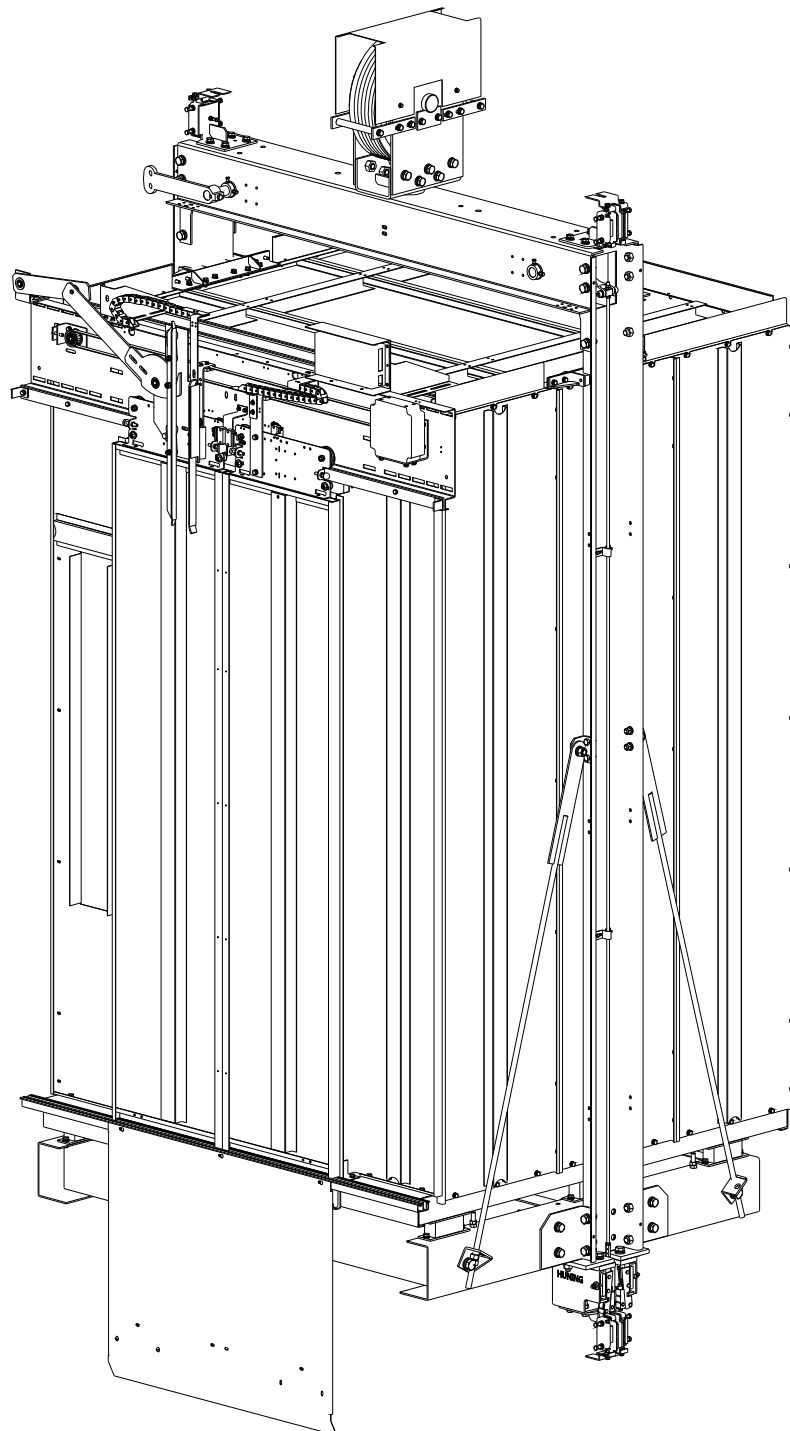

Figure 13-14

---

## 14 Installation of car door system

Car door system installation overview:



(CLD) XIZI

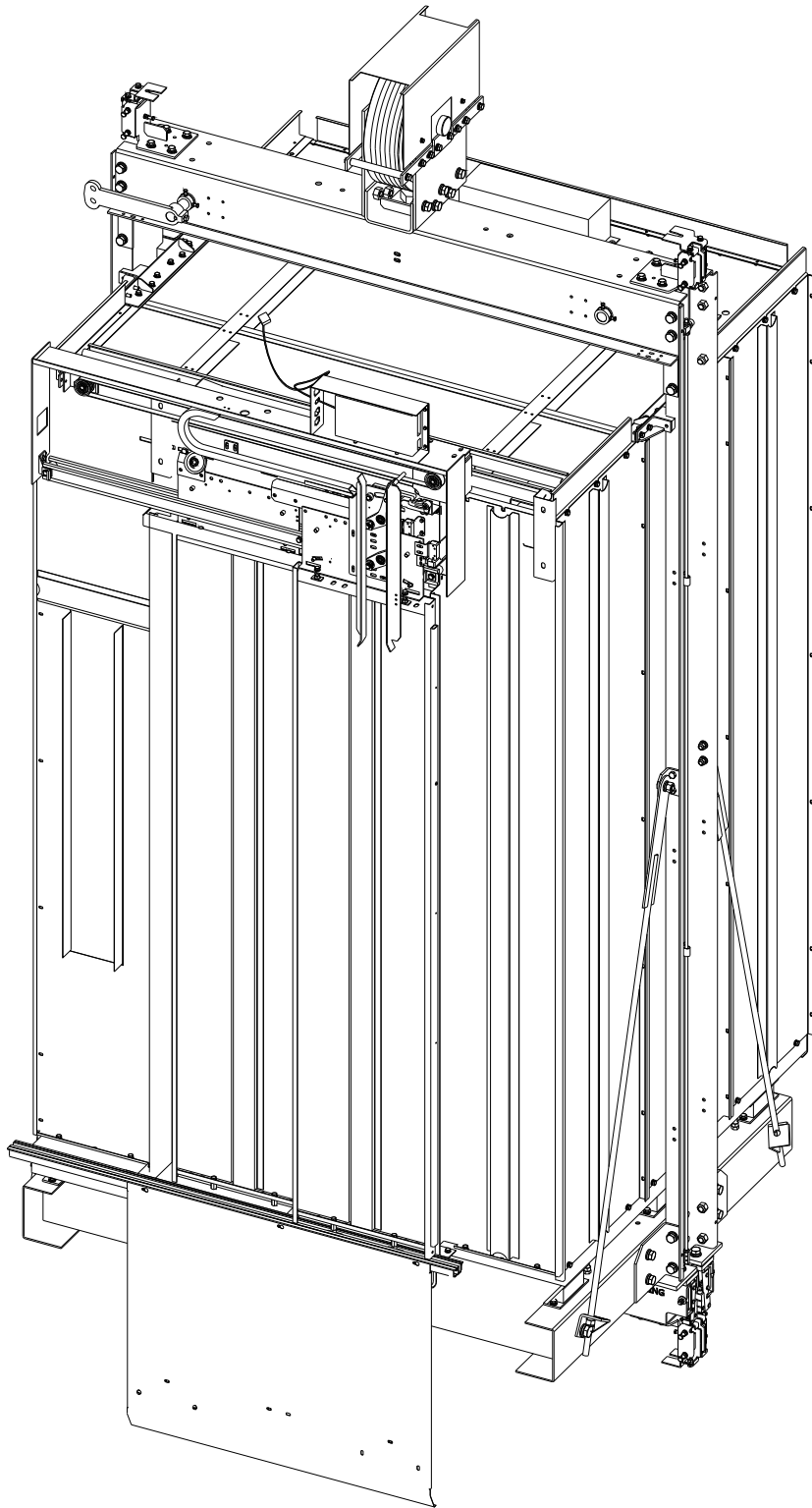

(TLD) XIZI

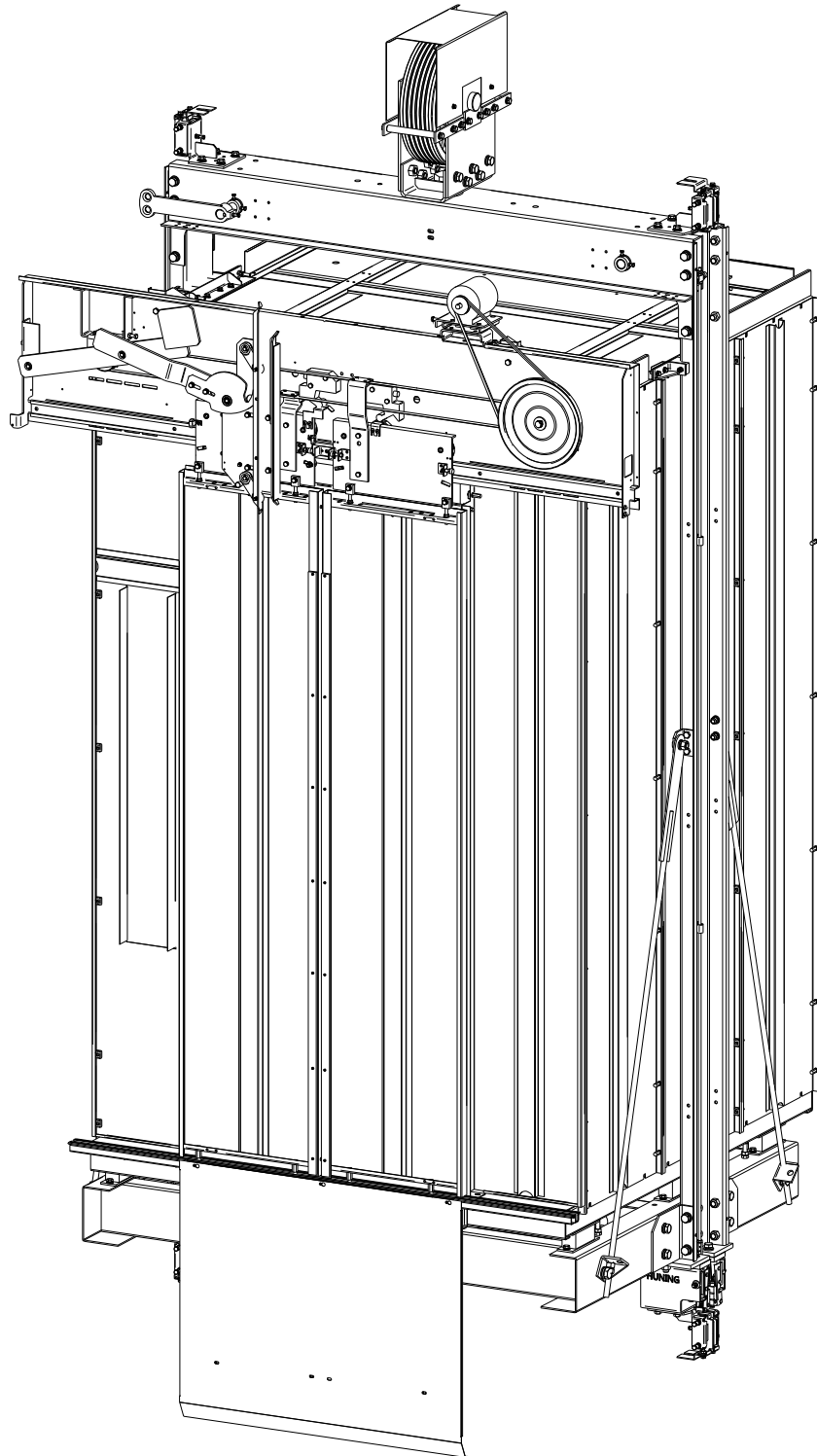

(CLD) NINGBOSHENLING

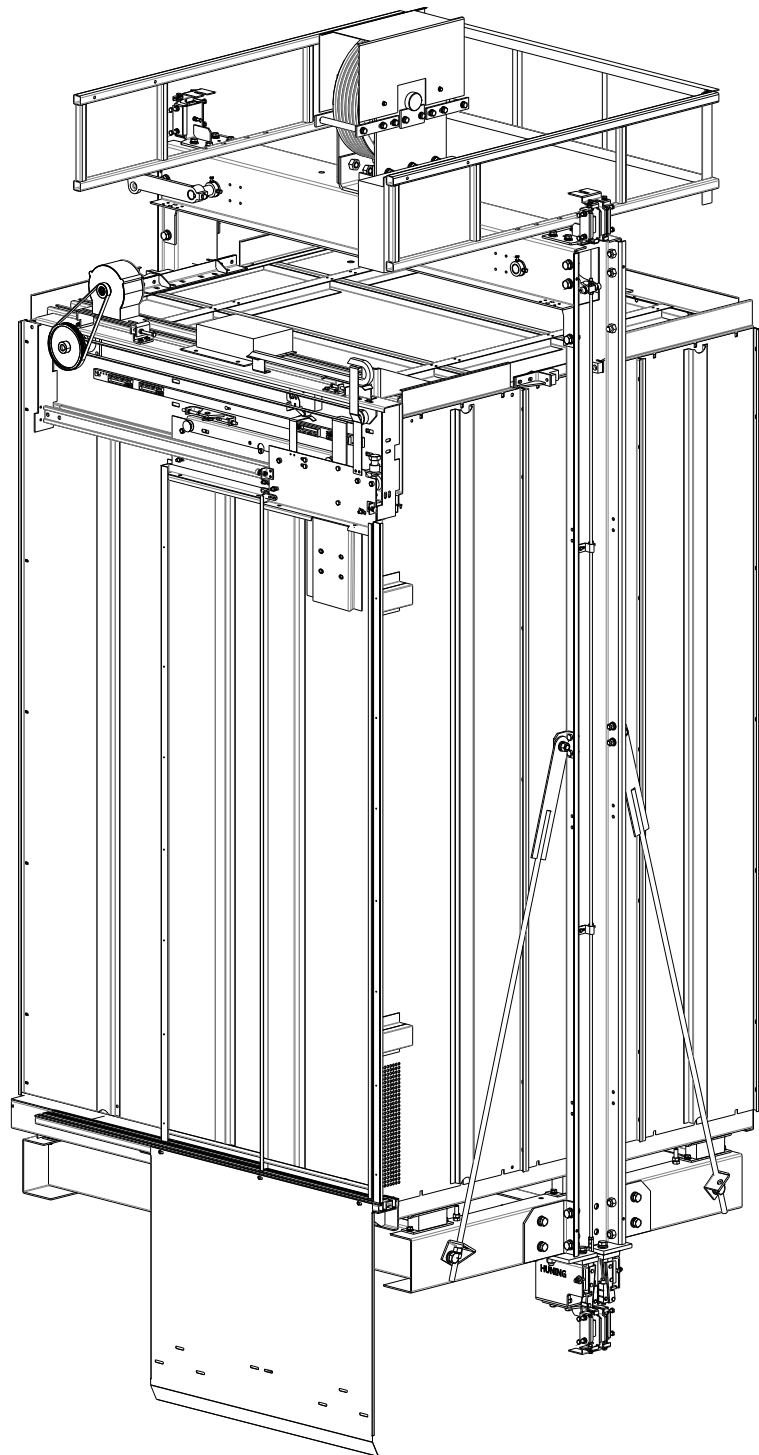

(TLD) NINGBOSHENLING



### 14.1 Installation of door operator

Step	Instruction	Fig
1	Connect the brackets on car ceiling.	Figure 14-1
2	Connect the door operator on brackets.	Figure 14-2

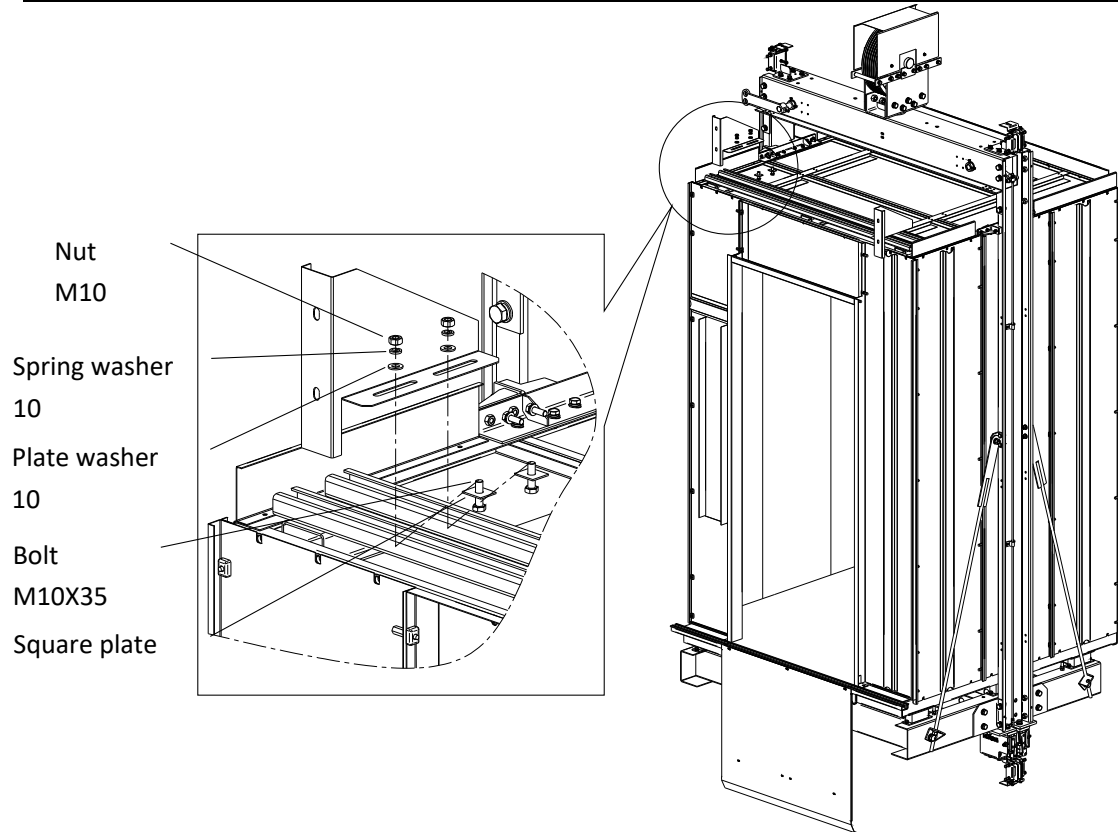

Figure 14-1(CLD)

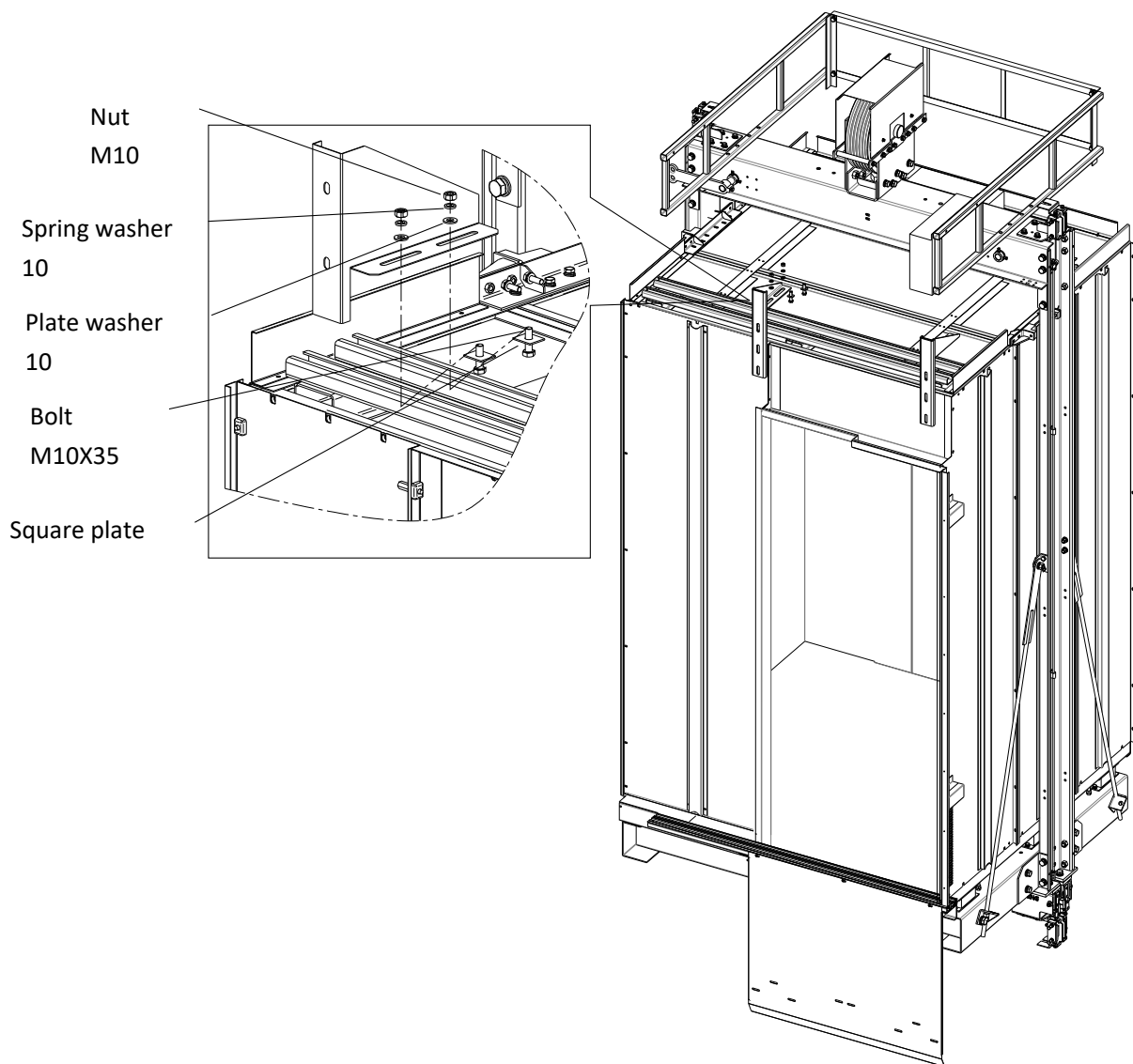

Figure 14-1(TLD)

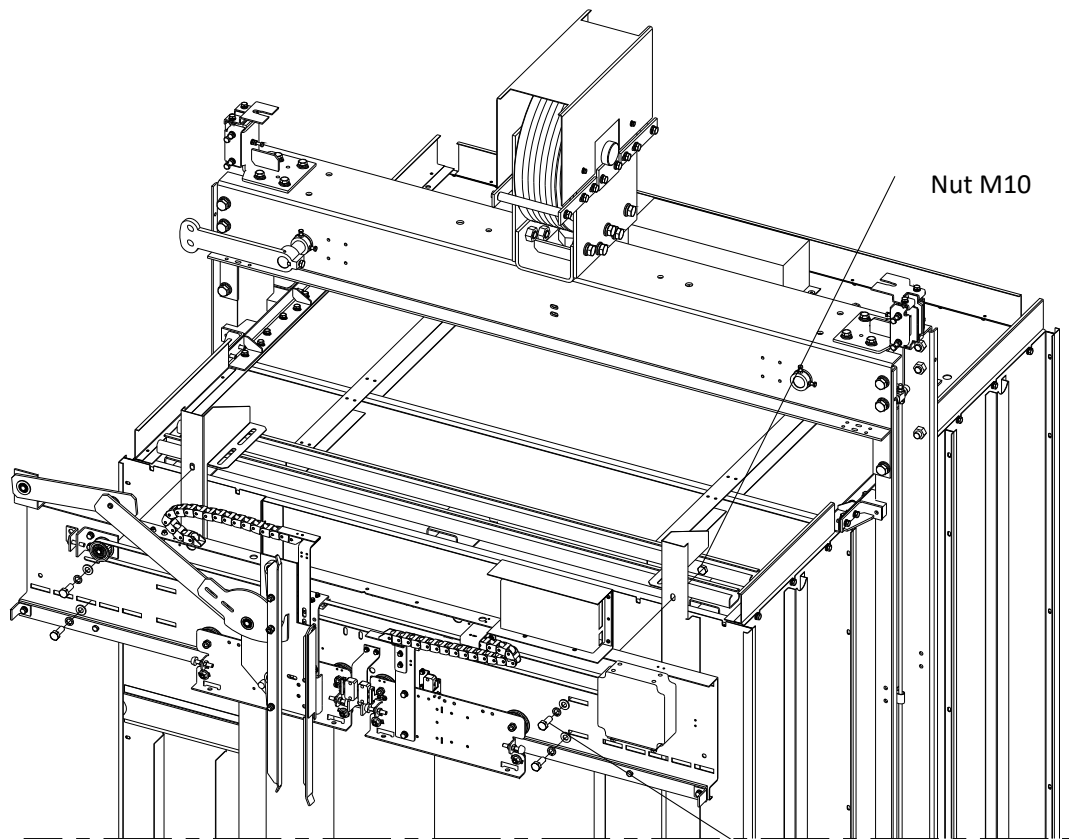

Figure 14-2(CLD) XIZI

Bolt M10X25  
Spring washer 10  
Plain washer 10

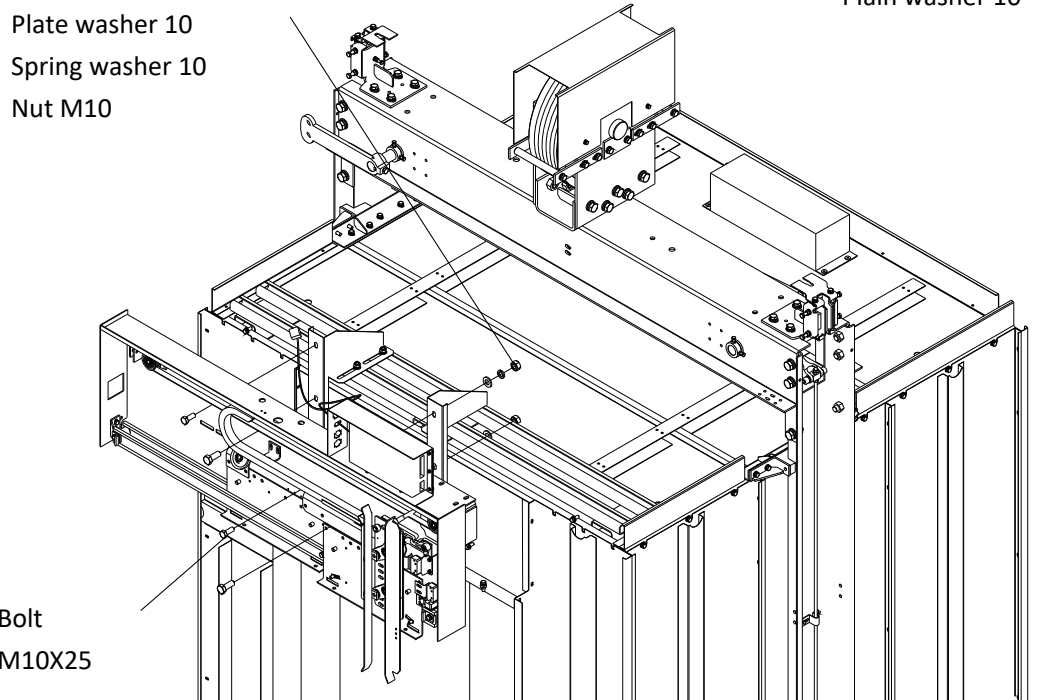

Figure 14-2(TLD) XIZI

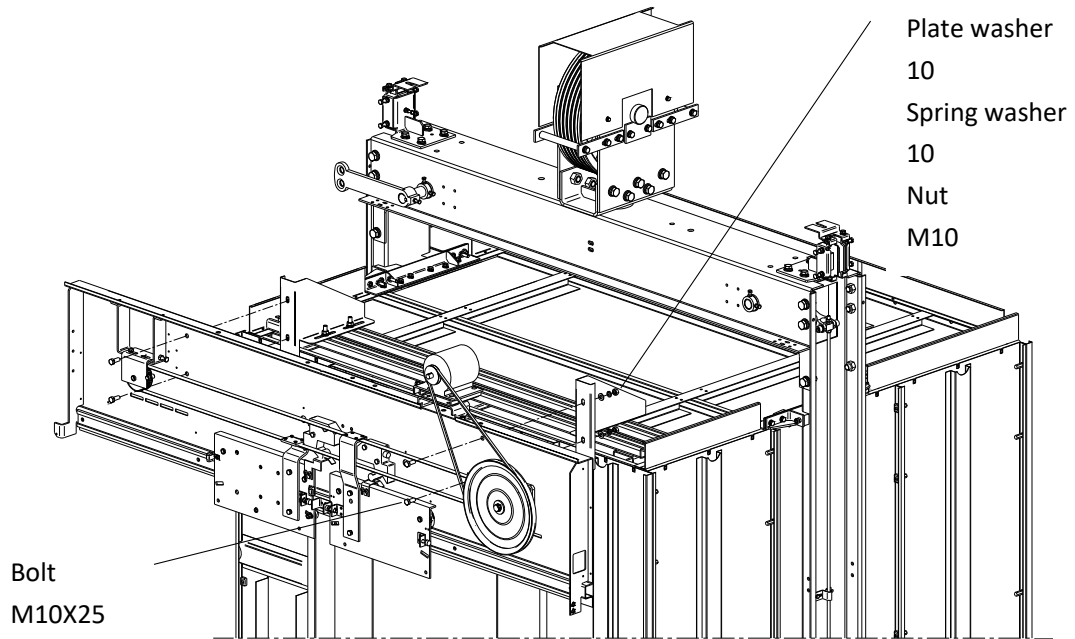

Figure 14-2(CLD) NINGBOSHENLING

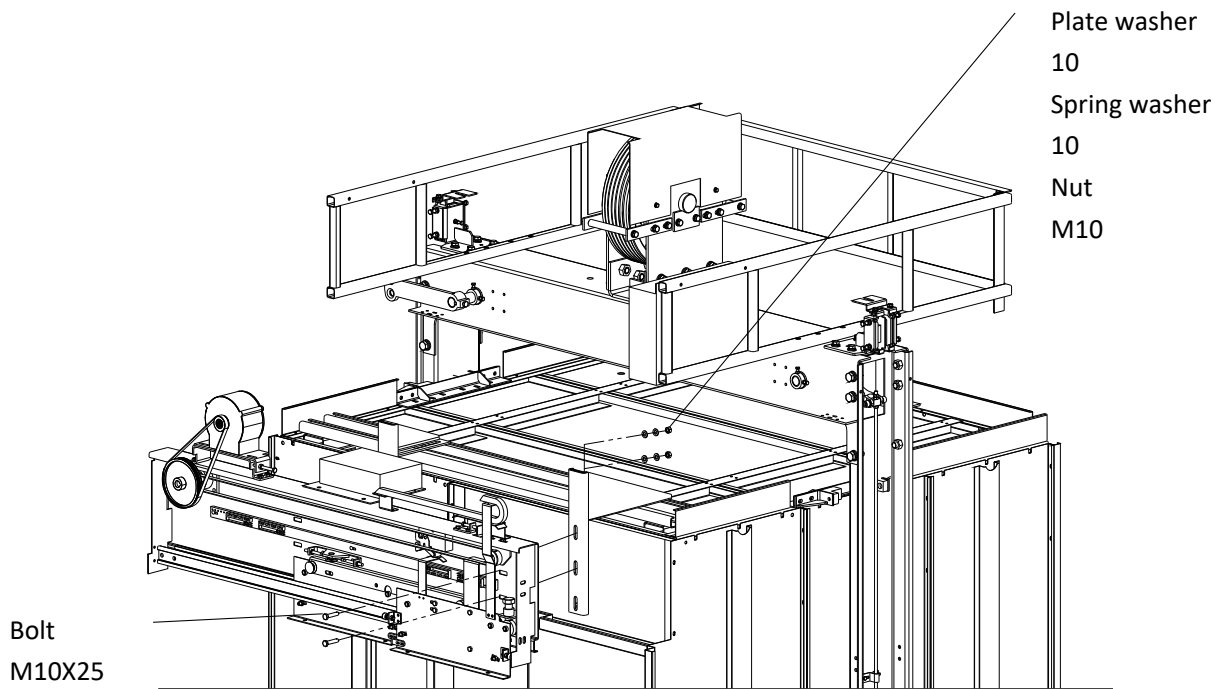

Figure 14-2(TLD) NINGBOSHENLING

## 14.2 Installation of car door panel

Step	Instruction	Fig
1	Connect car door panel to door operator and assemble guide shoes.	Figure 14-3
2	Install another panel by same way.	N/A
3	Adjust the door panel.	Figure 14-4, 14-5

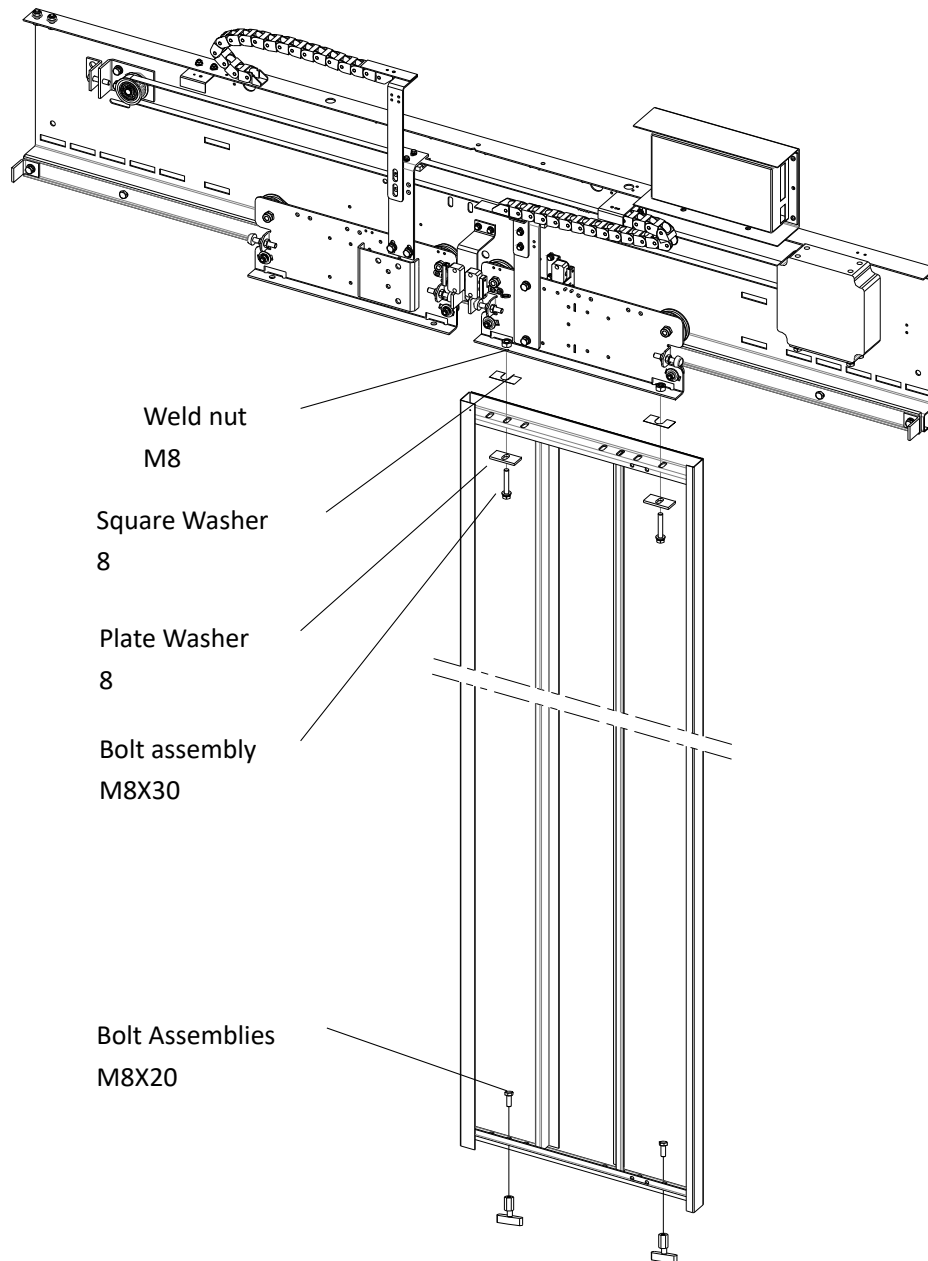

Figure 14-3(CLD) XIZI

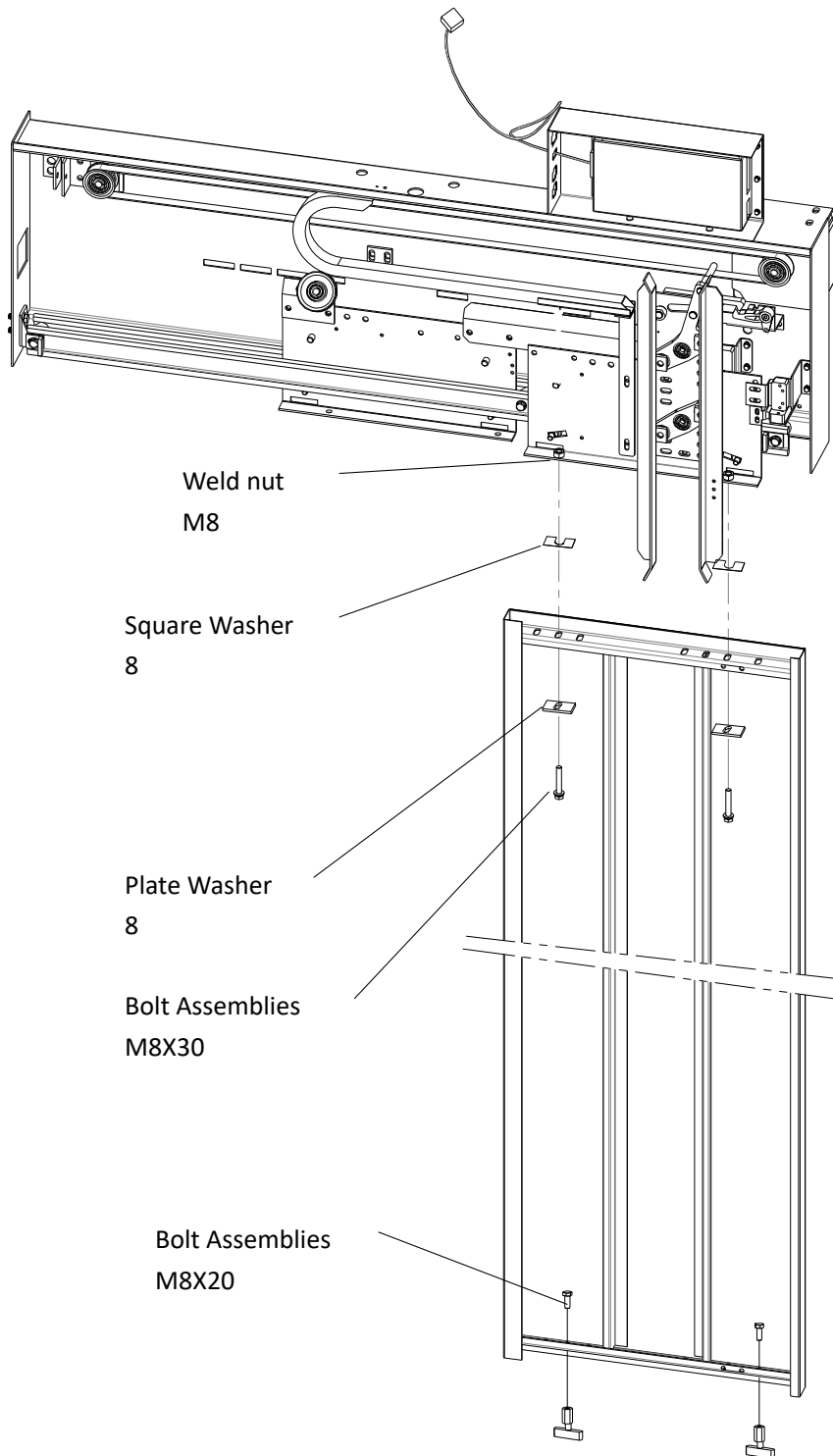

Figure 14-3(TLD) XIZI

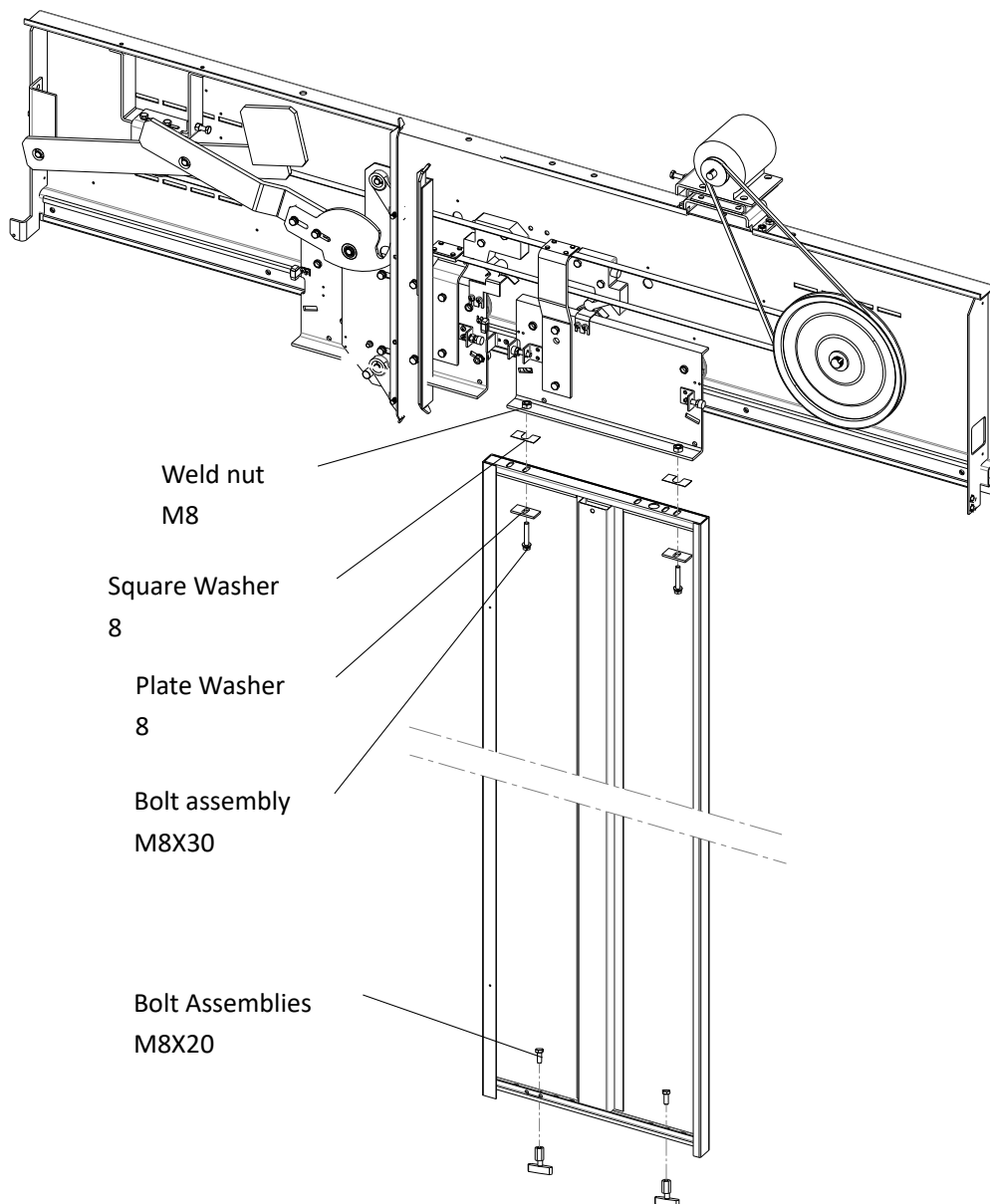

Figure 14-3(CLD) NINGBOSHENLING

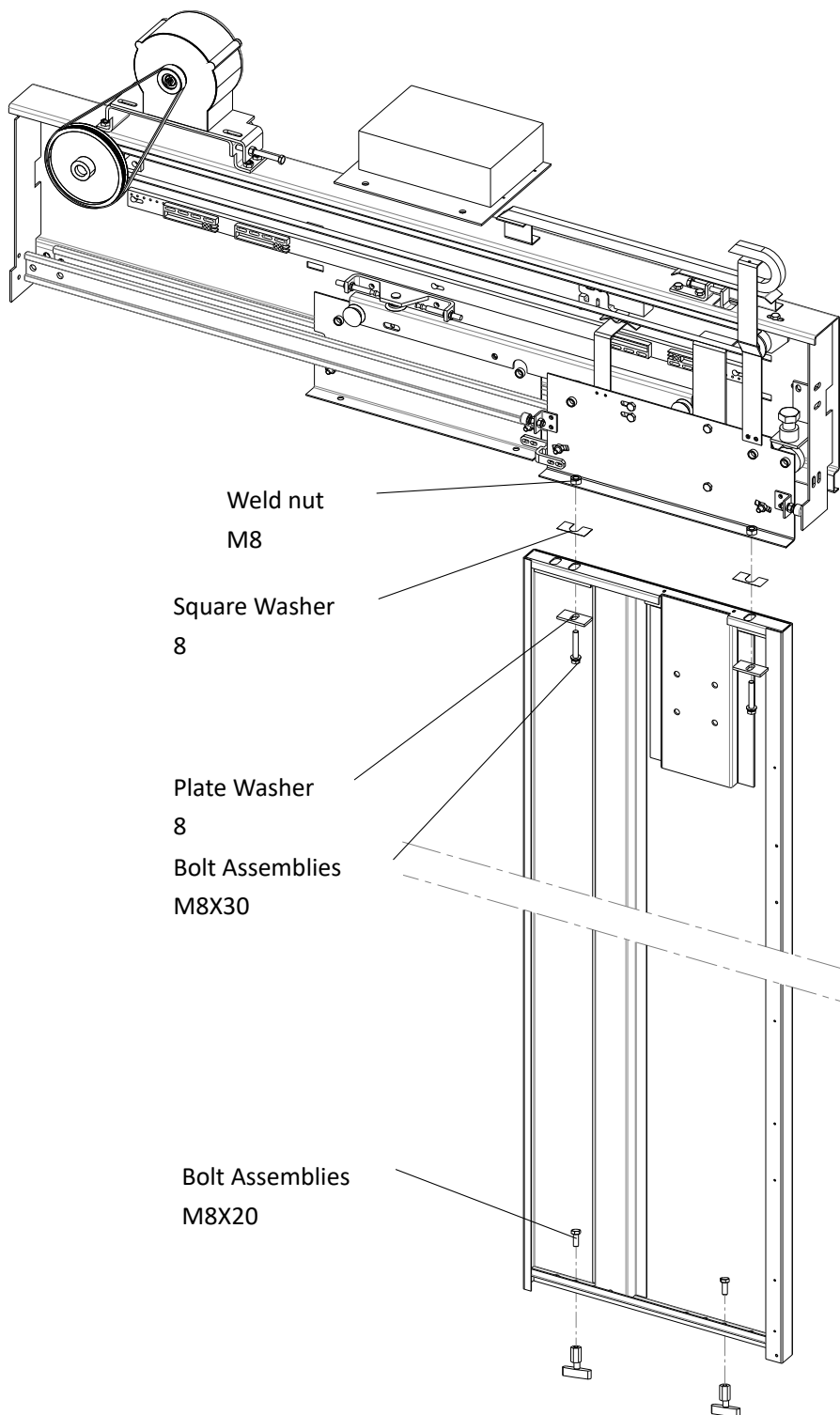

Figure 14-3(TLD) NINGBOSHENLING



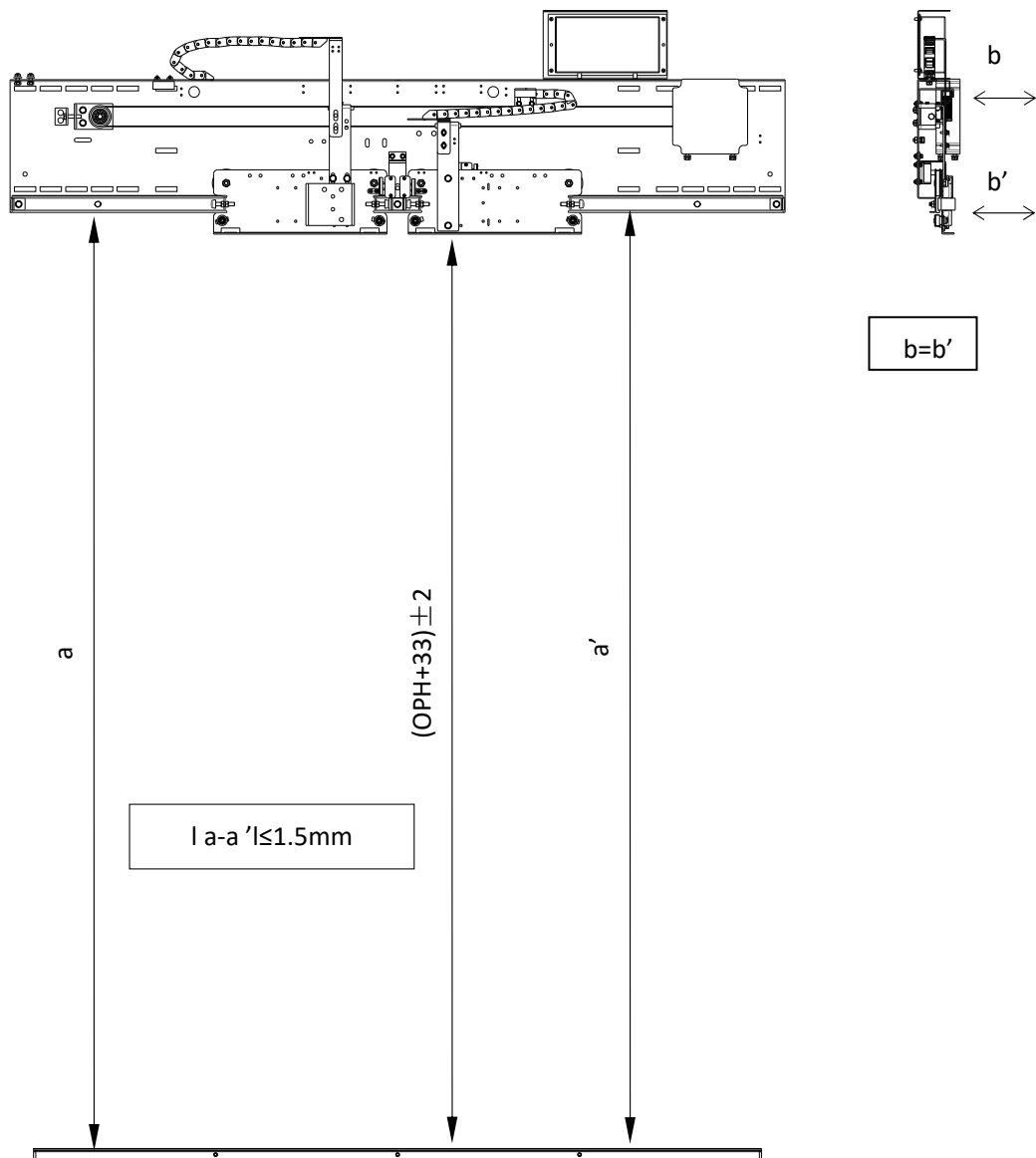

Figure 14-4(CLD) XIZI

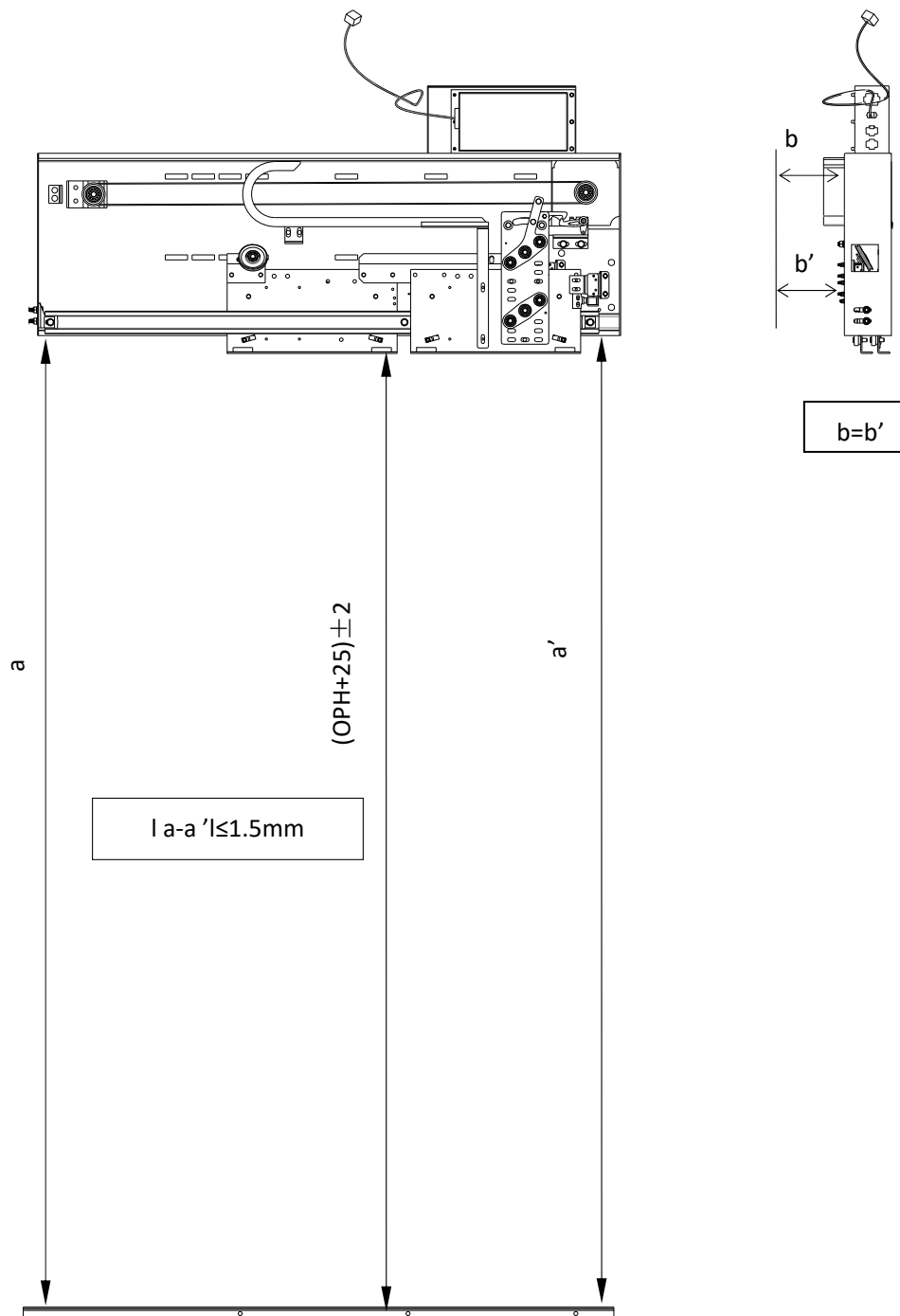

Figure 14-4(TLD) XIZI

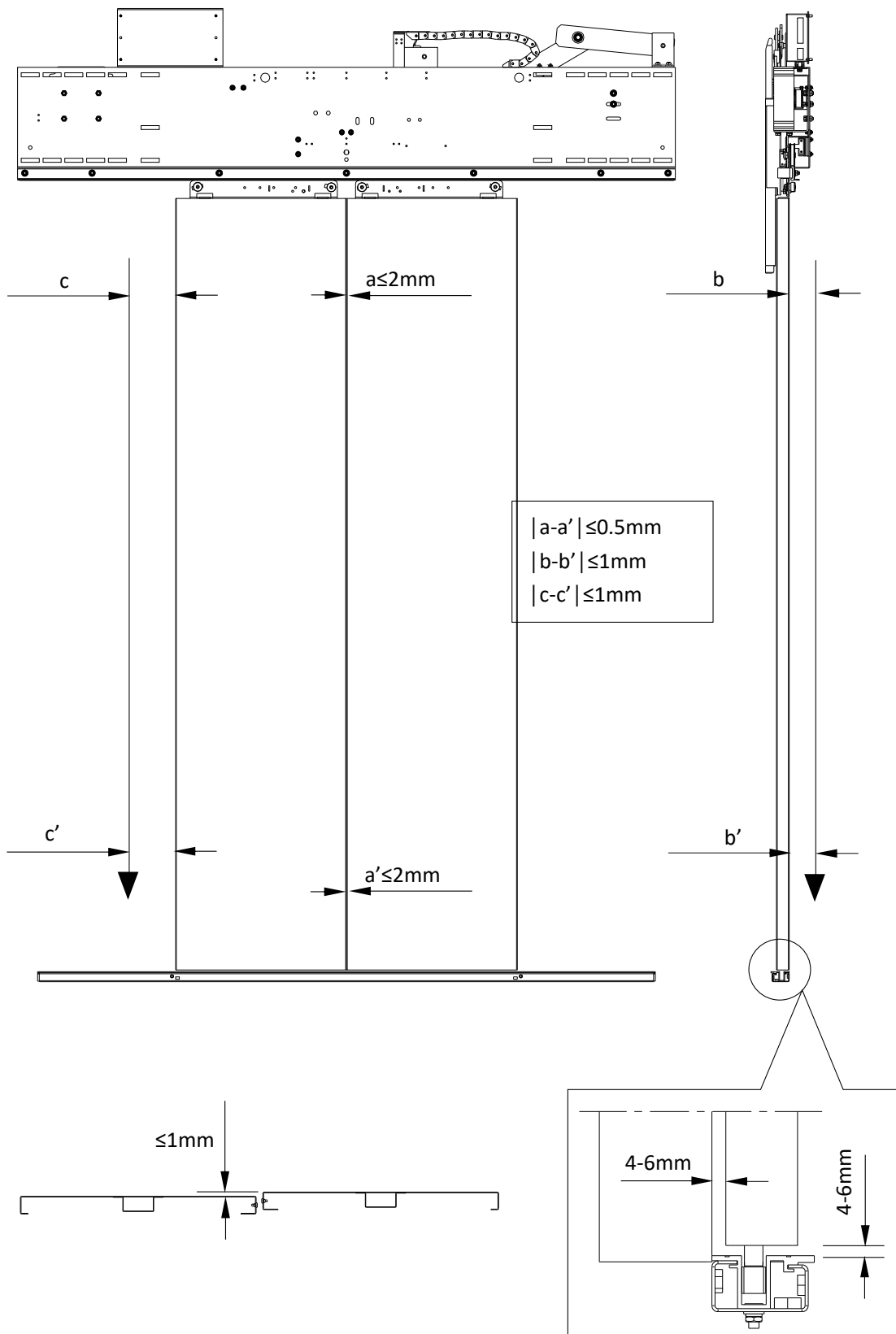

Figure 14-5(CLD) XIZI

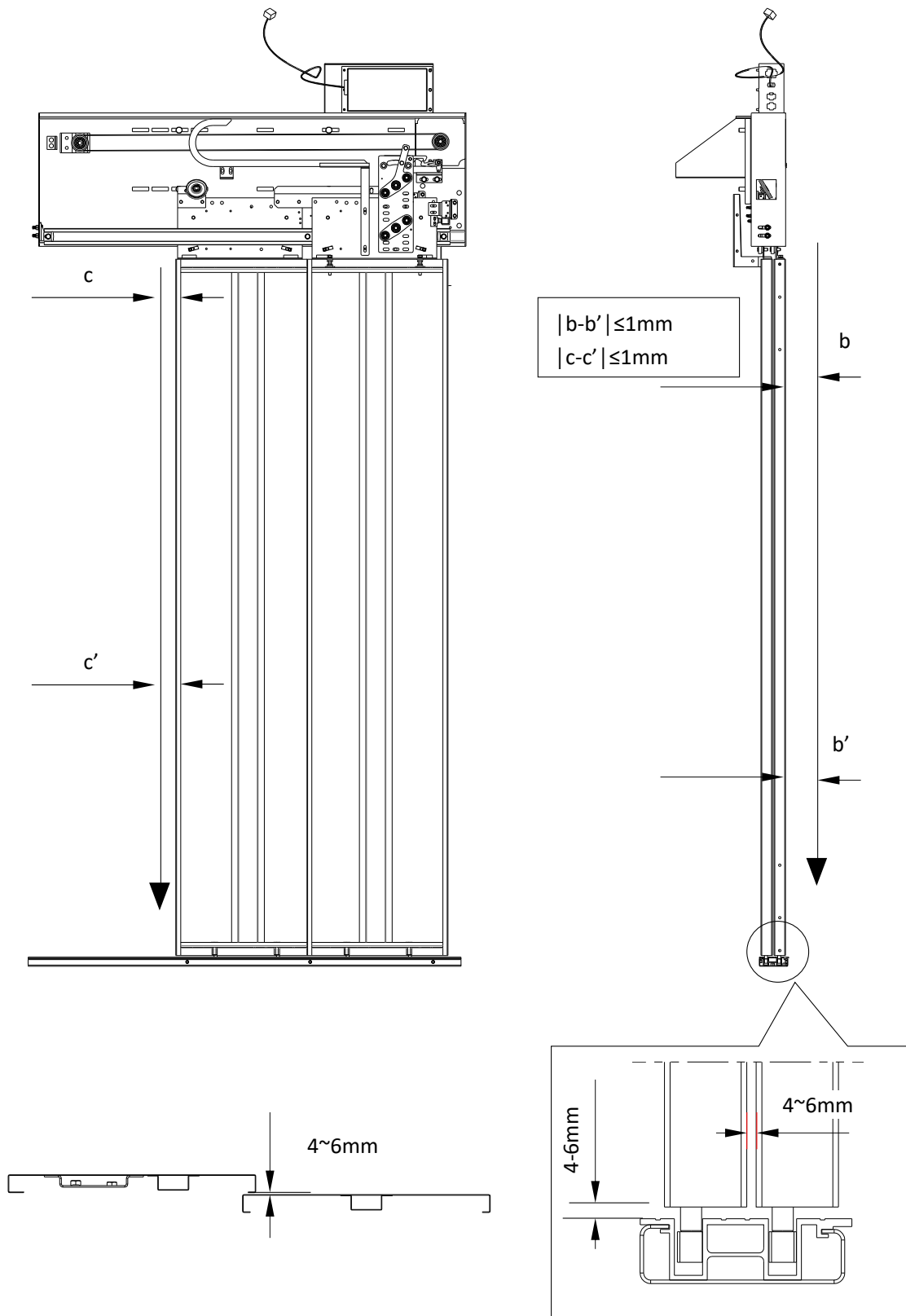

Figure 14-5(TLD) XIZI

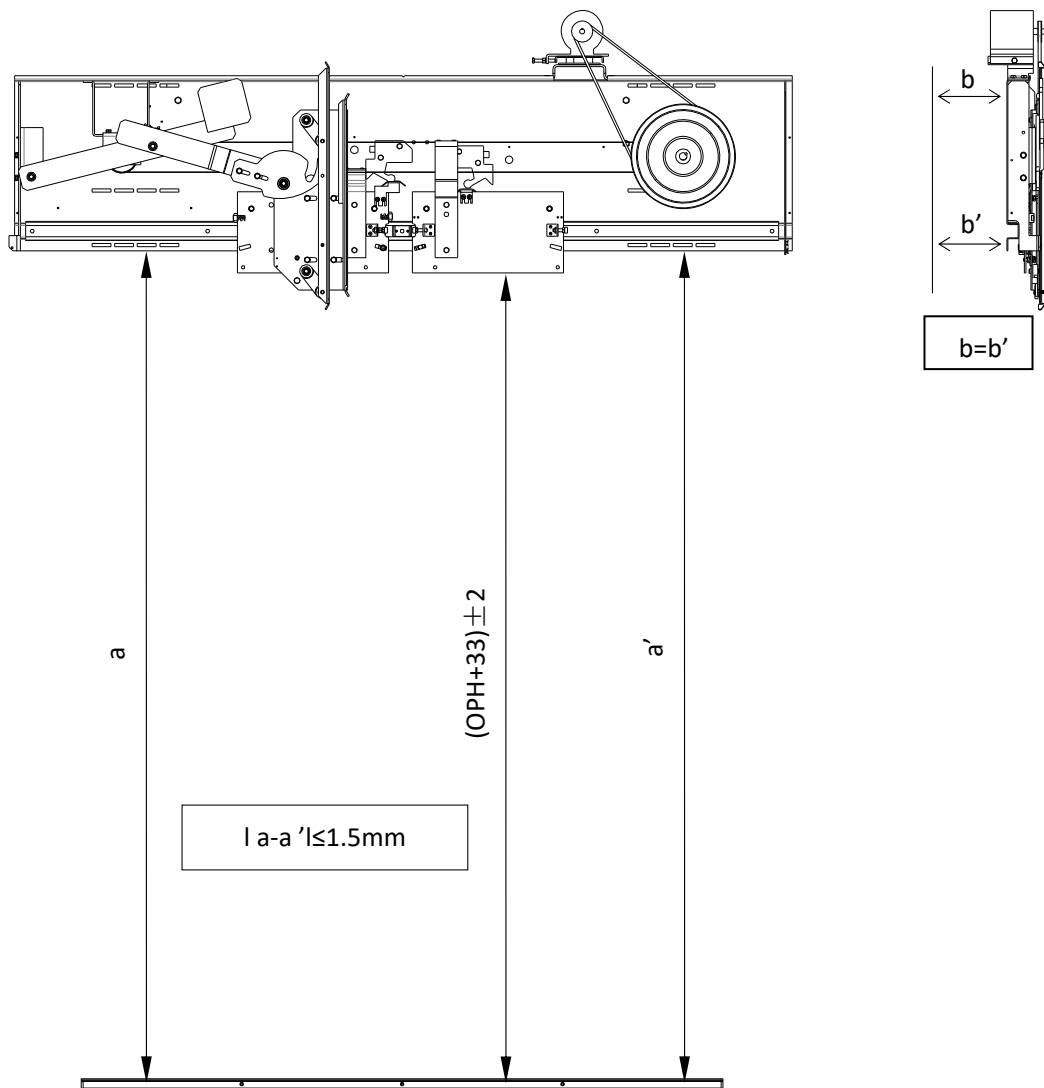

Figure 14-4(CLD) NINGBOSHENLING

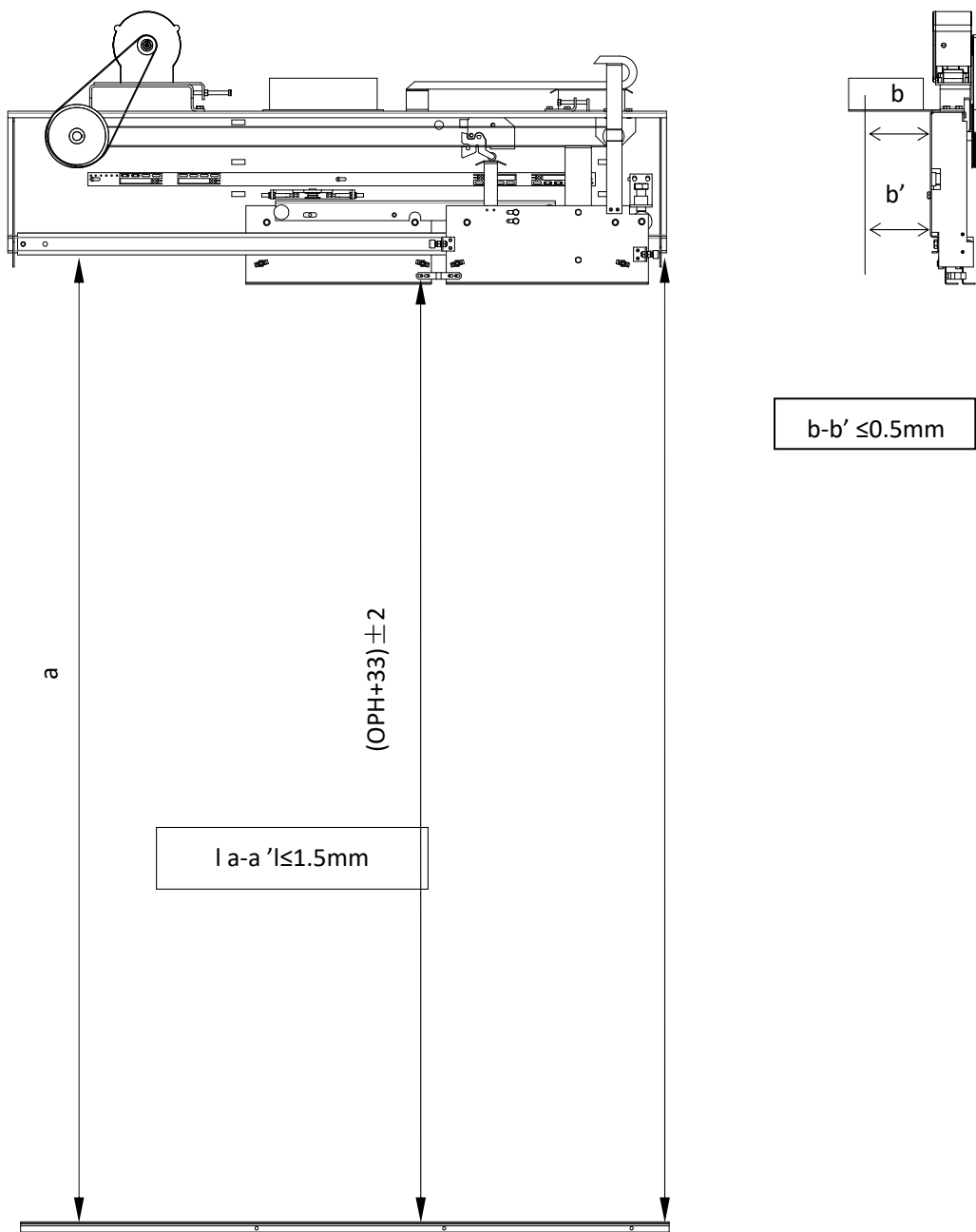

Figure 14-4(TLD) NINGBOSHENLING

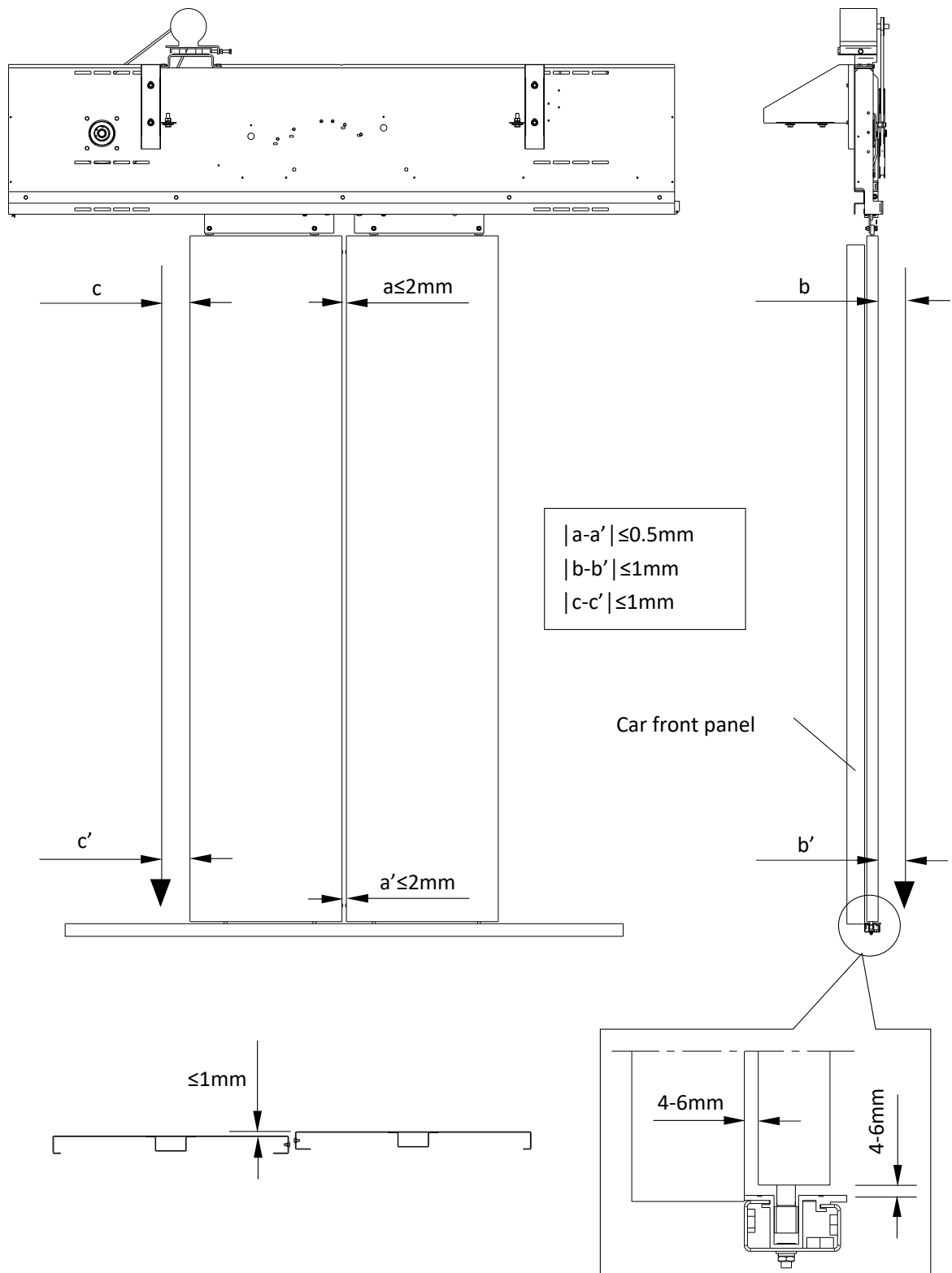

Figure 14-5(CLD) NINGBOSHENLING

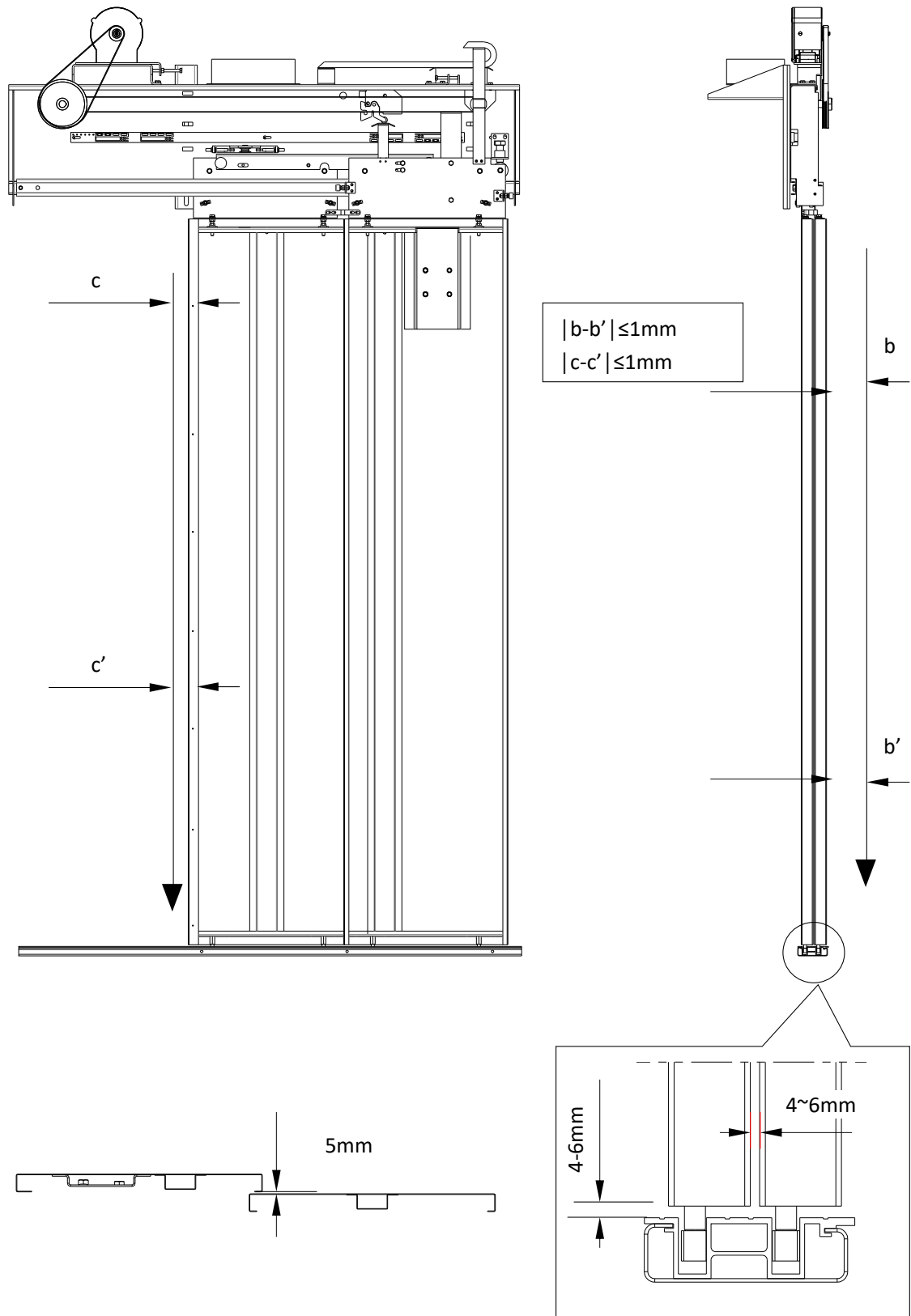
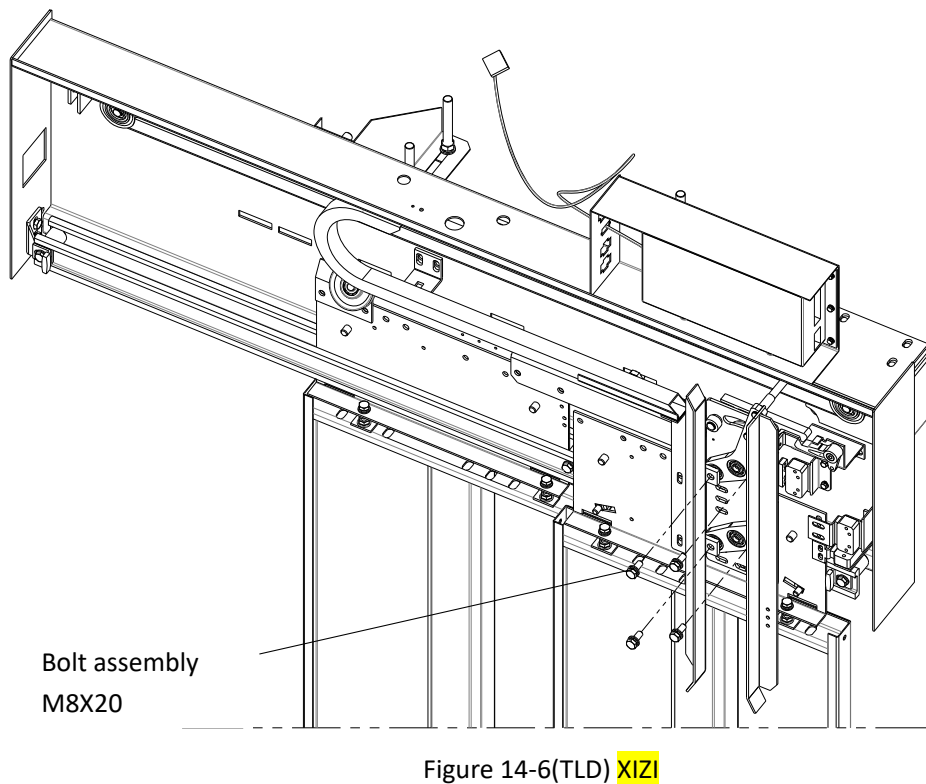
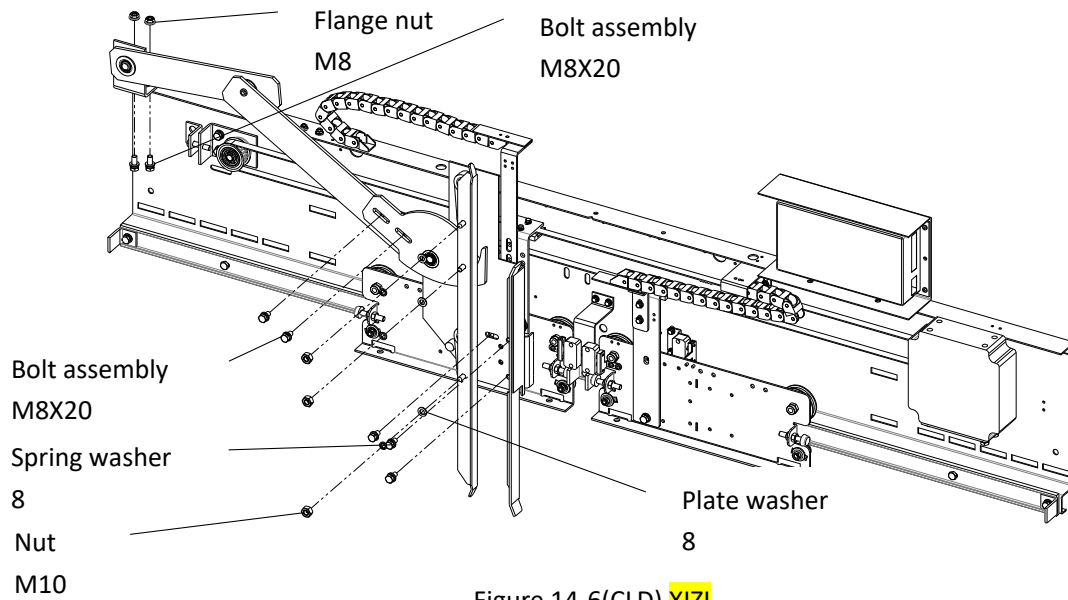

Figure 14-5(TLD) NINGBOSHENLING



### 14.3 Installation of door vane

Step	Instruction	Fig
1	Fix door vane on door operator.	Figure 14-6
2	Adjust of door vane.	Figure 14-7



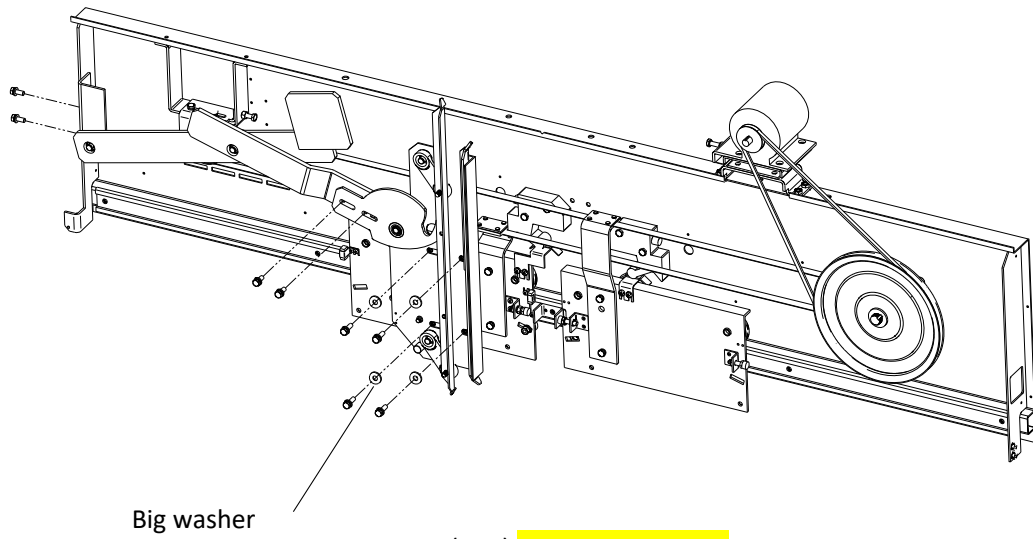

Figure 14-6(CLD) NINGBOSHENLING

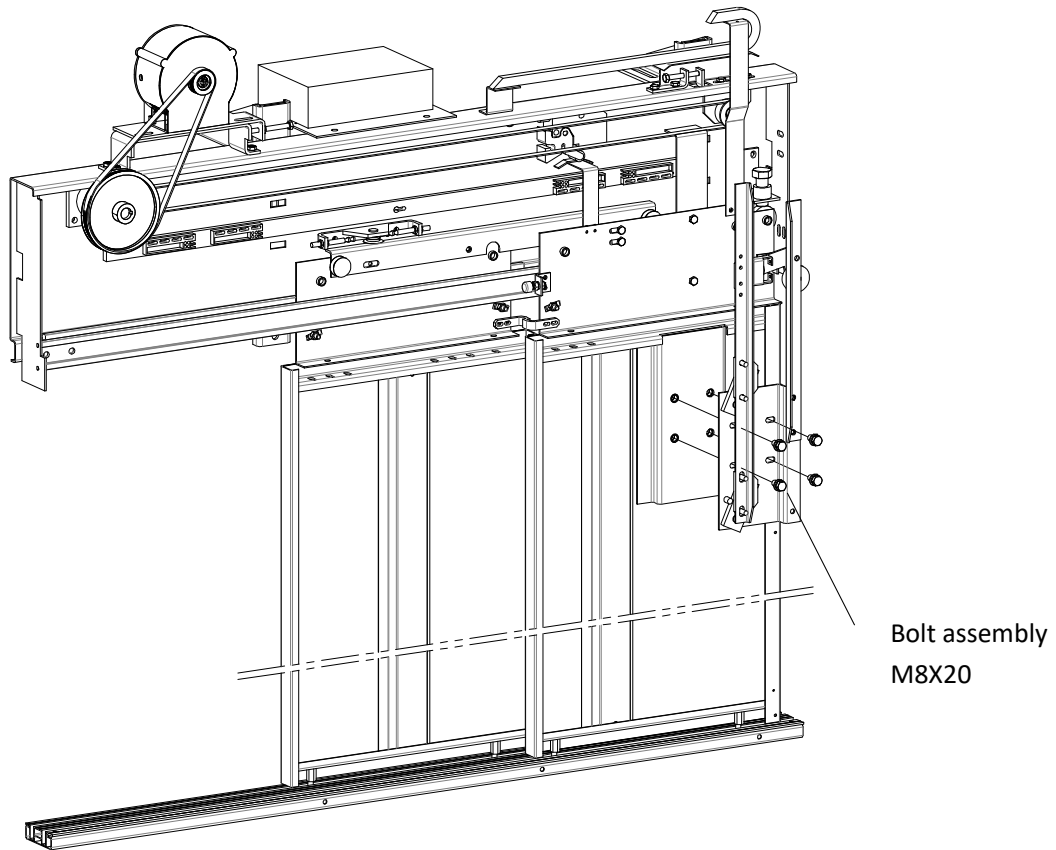

Figure 14-6(TLD) NINGBOSHENLING

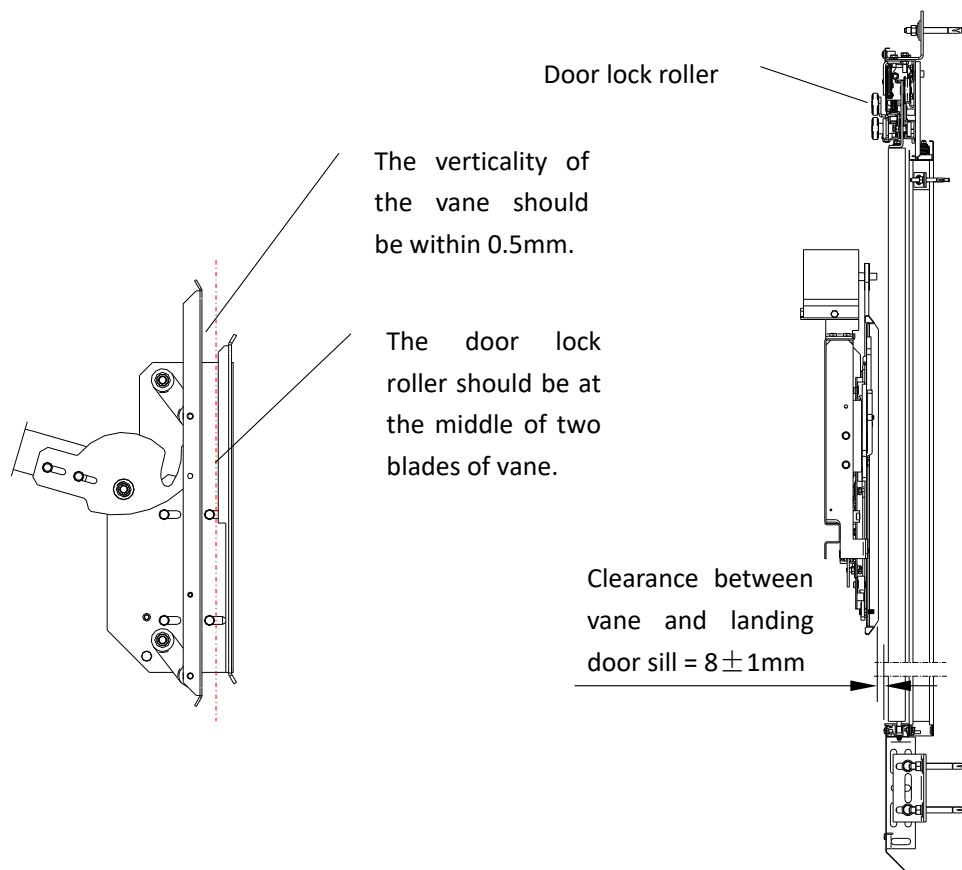

Figure 14-7(CLD)

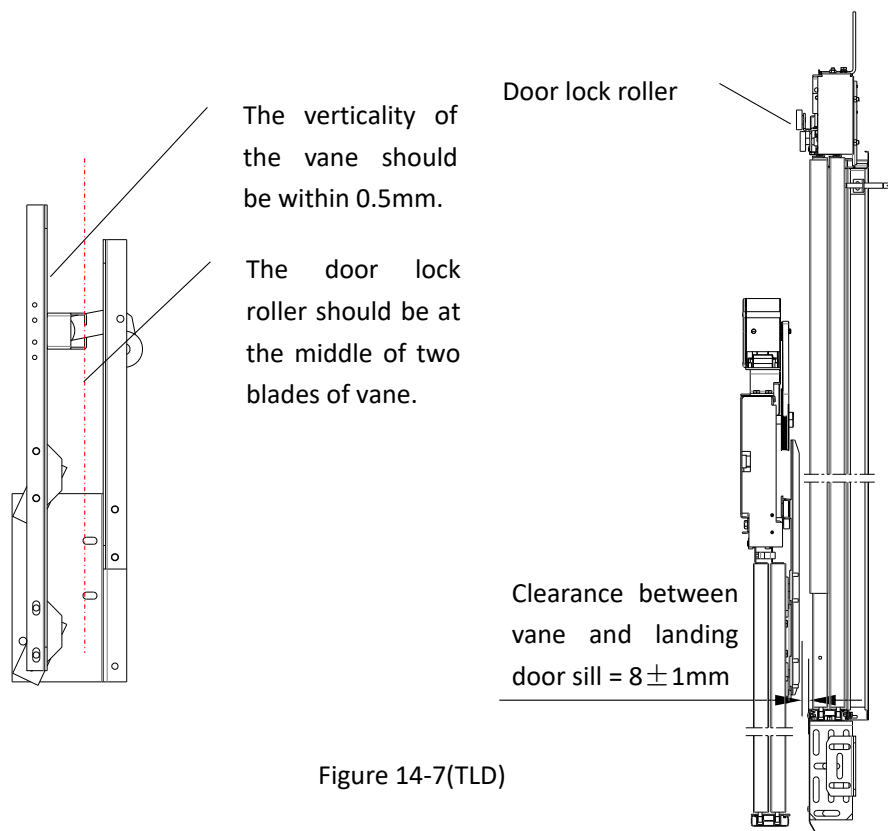

Figure 14-7(TLD)

### 14.4 Installation of door protection device

Step	Instruction	Fig
1	Installation of light curtain.	Figure 14-8

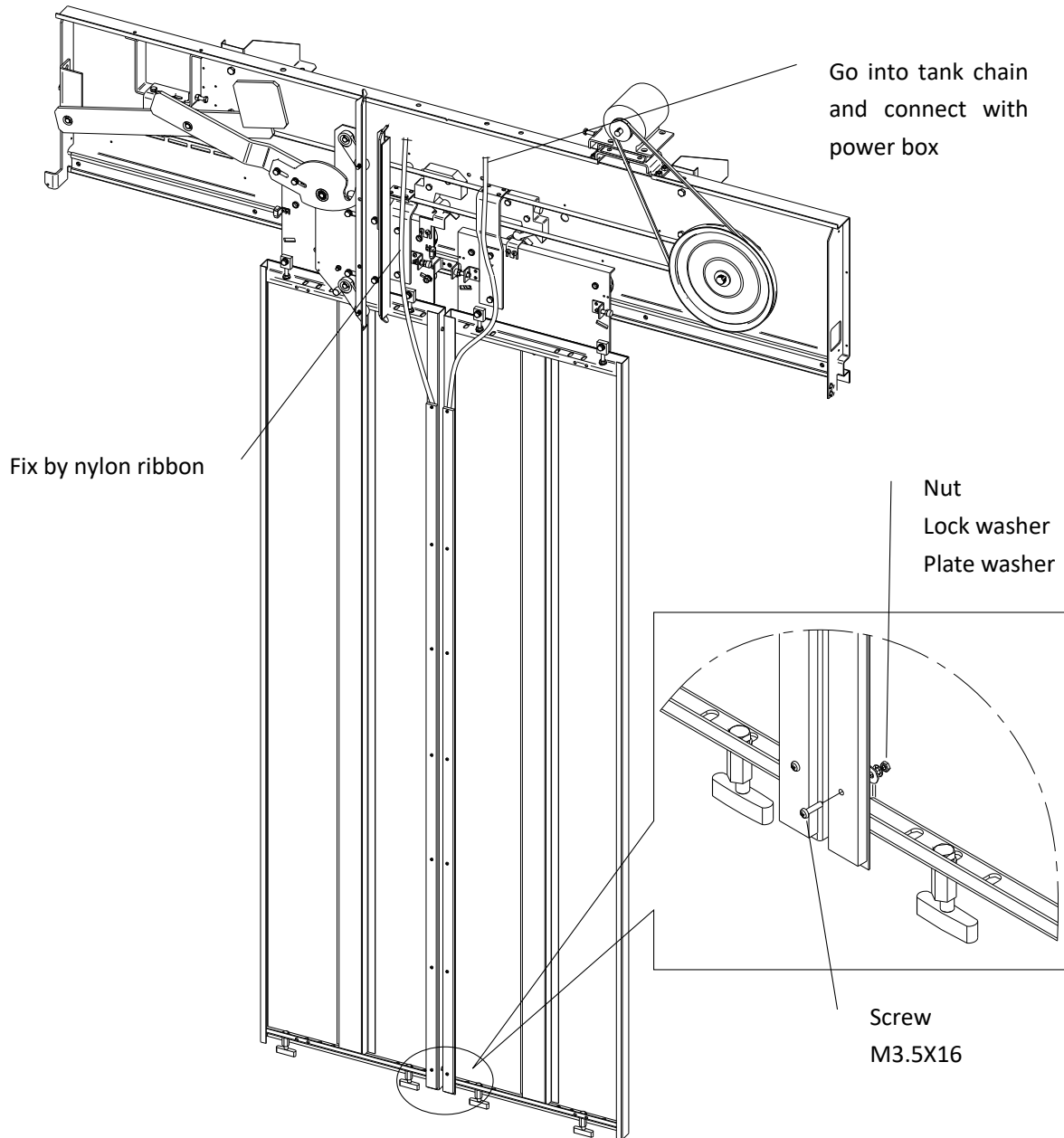

Figure 14-8(CLD)

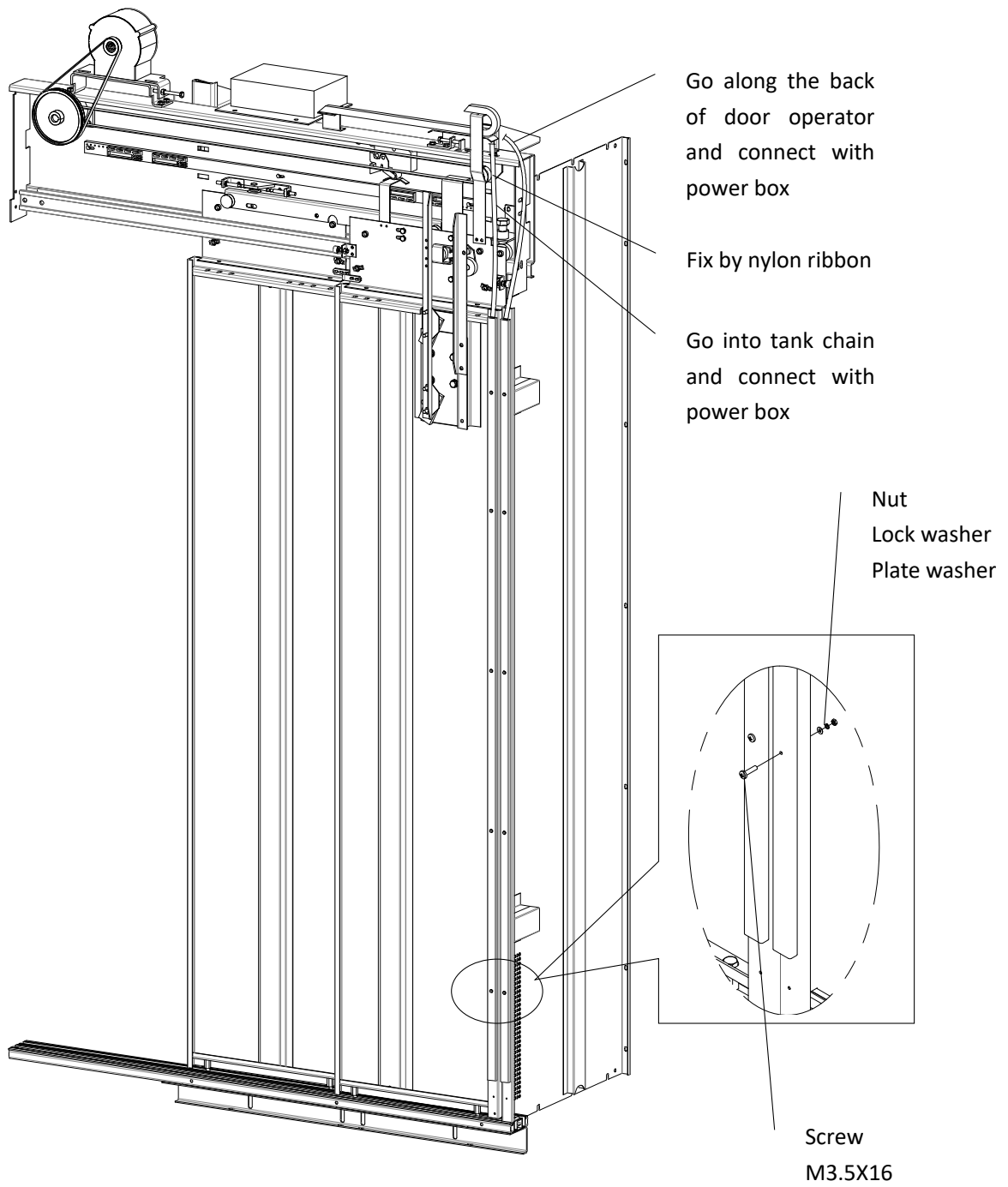
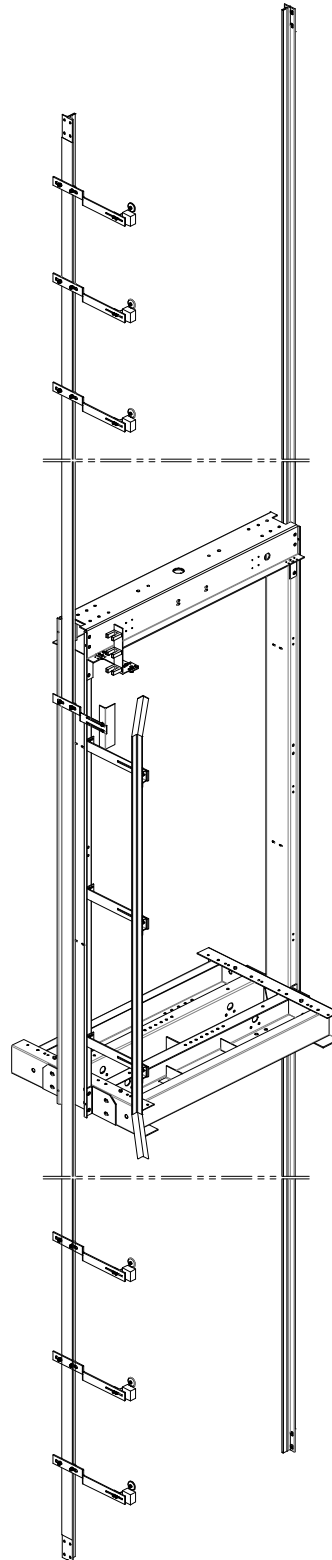

Figure 14-8(TLD)

---

## 15 Installation of position reference system

Position reference system installation overview:



### 15.1 Installation of limit switch

Step	Instruction	Fig
1	Connect the limit switch support on the guide	Figure 15-1
2	Connect the cam on the upright.	Figure 15-1
3	The switches installation dimension in the different elevator rated speed.	Figure 15-2

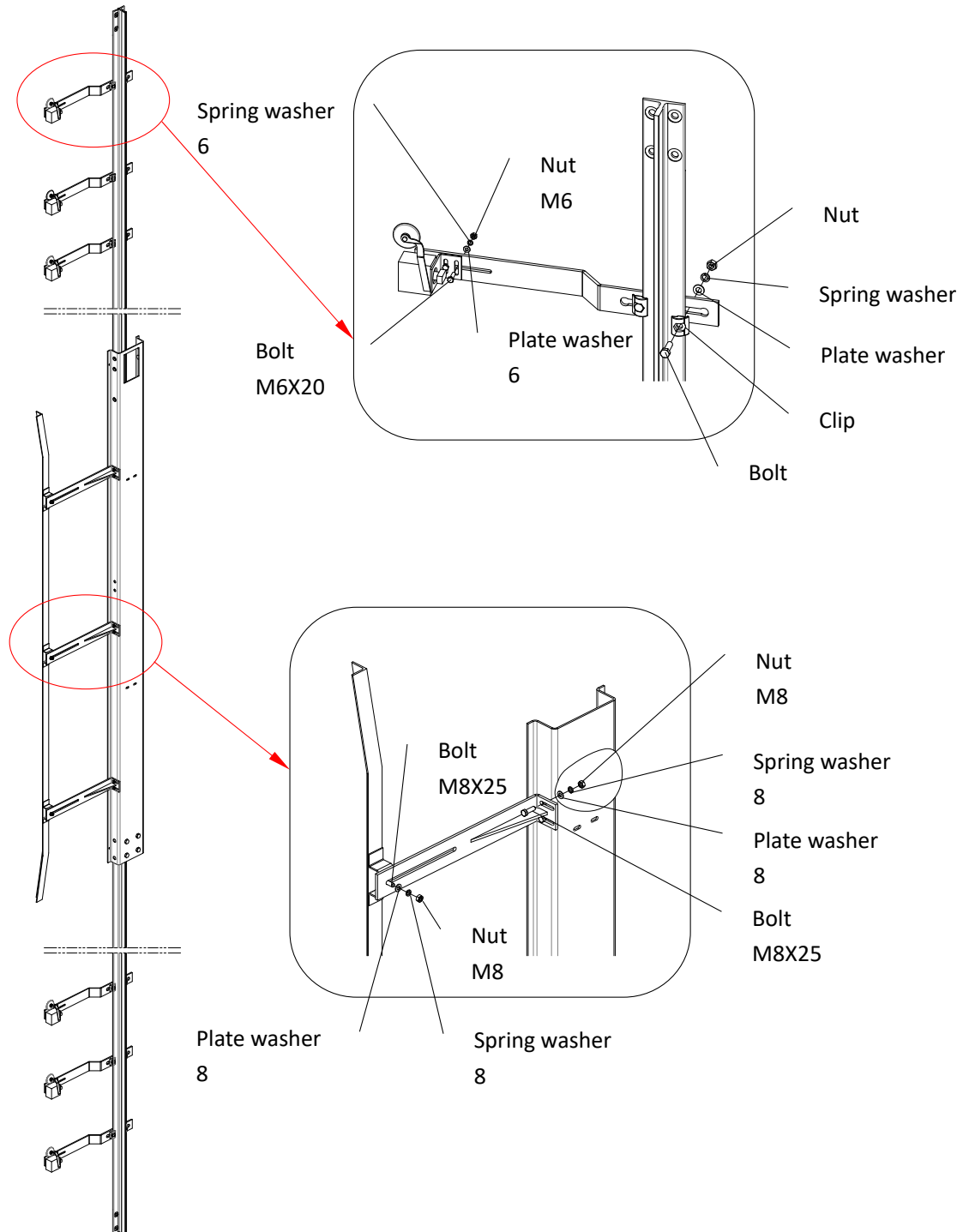

Figure 15-1

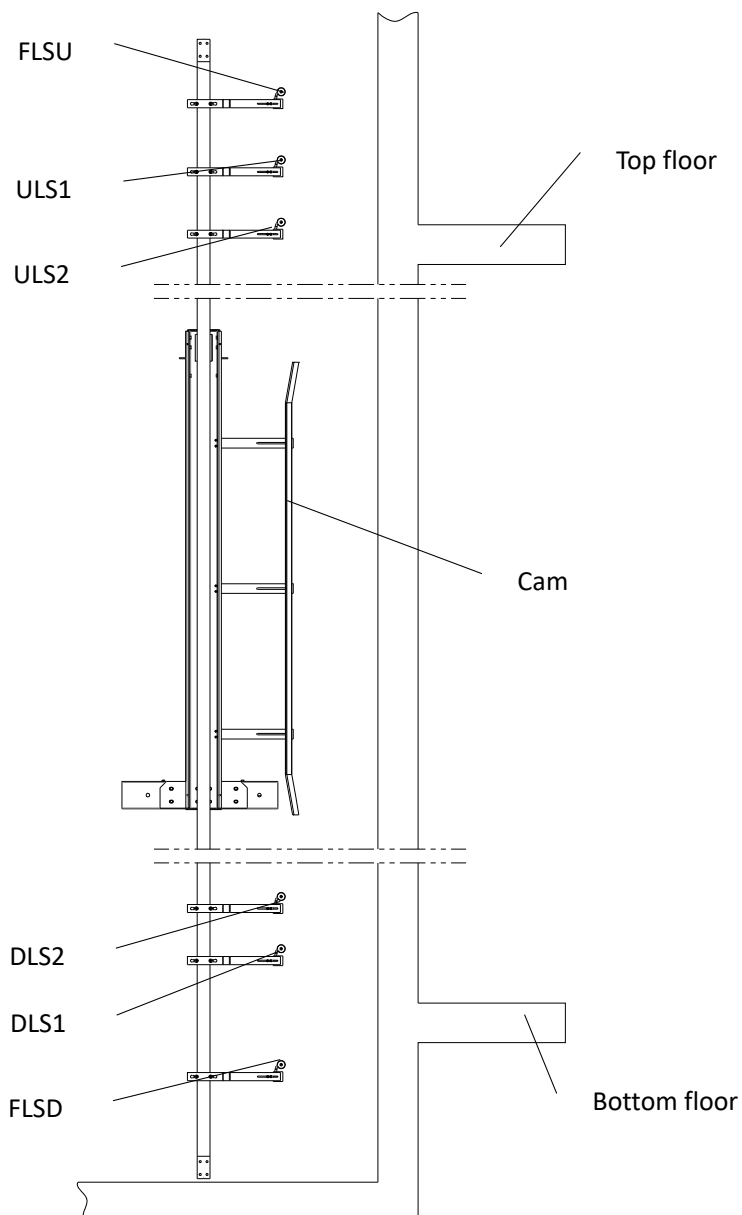

Figure 15-2

The switches installation dimension in the different elevator rated speed, shown as below.  
(unit: mm)

(The switches installation dimension should be the distance between the car sill and the landing door sill at this floor when the car running to the top or bottom floor in inspection speed as well as the switch switches-off.)

Speed (m/s)	DLS2,ULS2	DLS1,ULS1	FLSD, FLSU
1.0/1.50/1.75		-2400 mm	+150mm
2.00/2.50	-4500 mm	-2400 mm	+150mm



## 15.2 Installation of leveling device

Step	Instruction	Fig
1	Connect the leveling sensor on the car cross-head.	Figure 15-3
2	Connect the leveling sensor trigger plate on the guide at each floor.	Figure 15-3

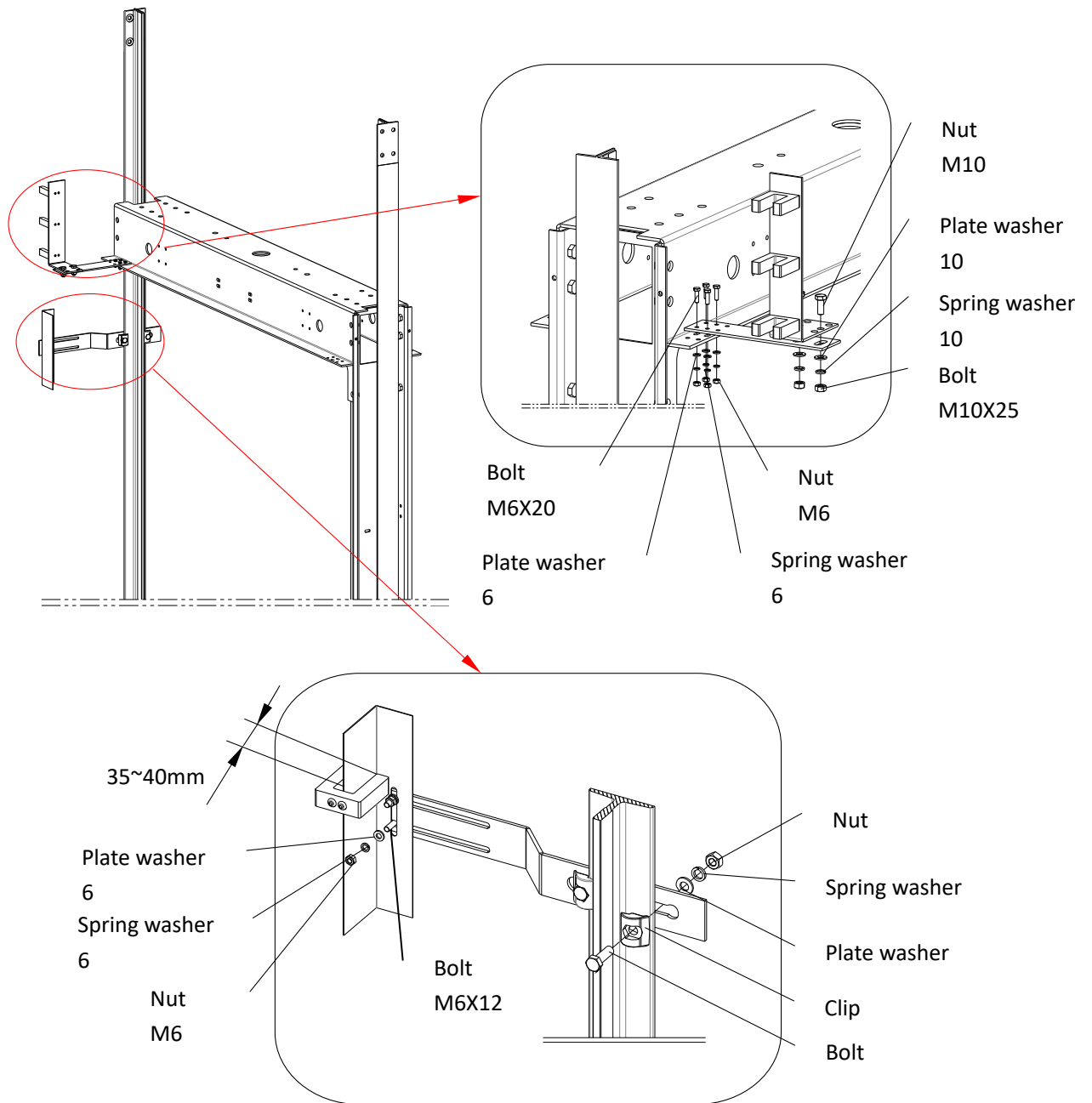

Figure 15-3

## 16 Installation of wiring

### 16.1 Installation of travelling cable

Step	Instruction	Fig
1	Fix the cable bracket on rail and sub-frame.	Figure 16-1/16-2
2	Fix the travelling cable on brackets.	Figure 16-1/16-2
3	Protection of the travelling cable.	Figure 16-3

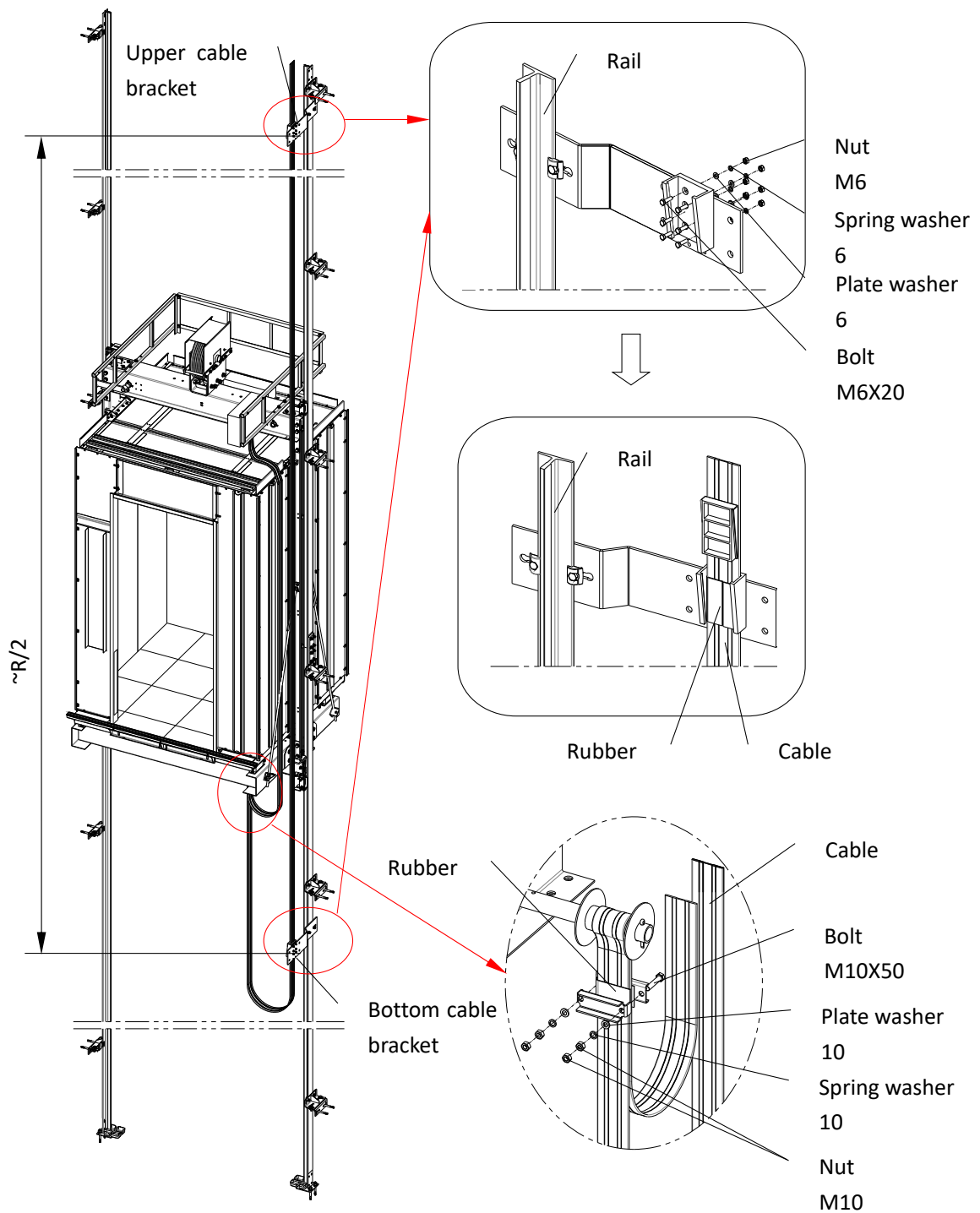

Figure 16-1 (R ≤ 60m)

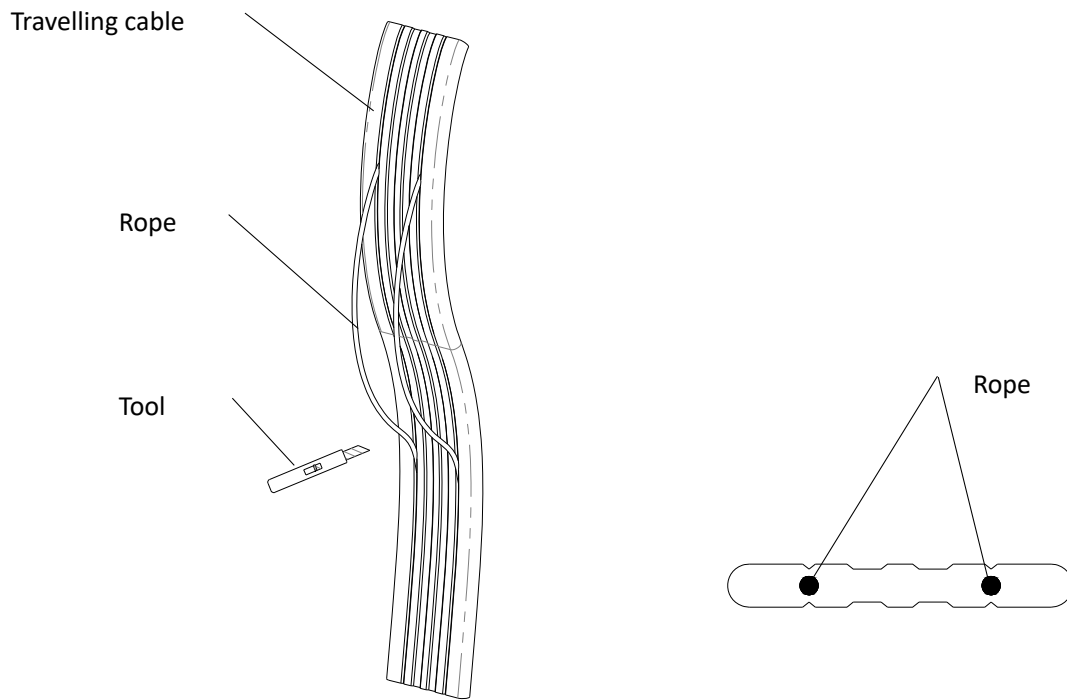

Figure 16-2 (R>60m)

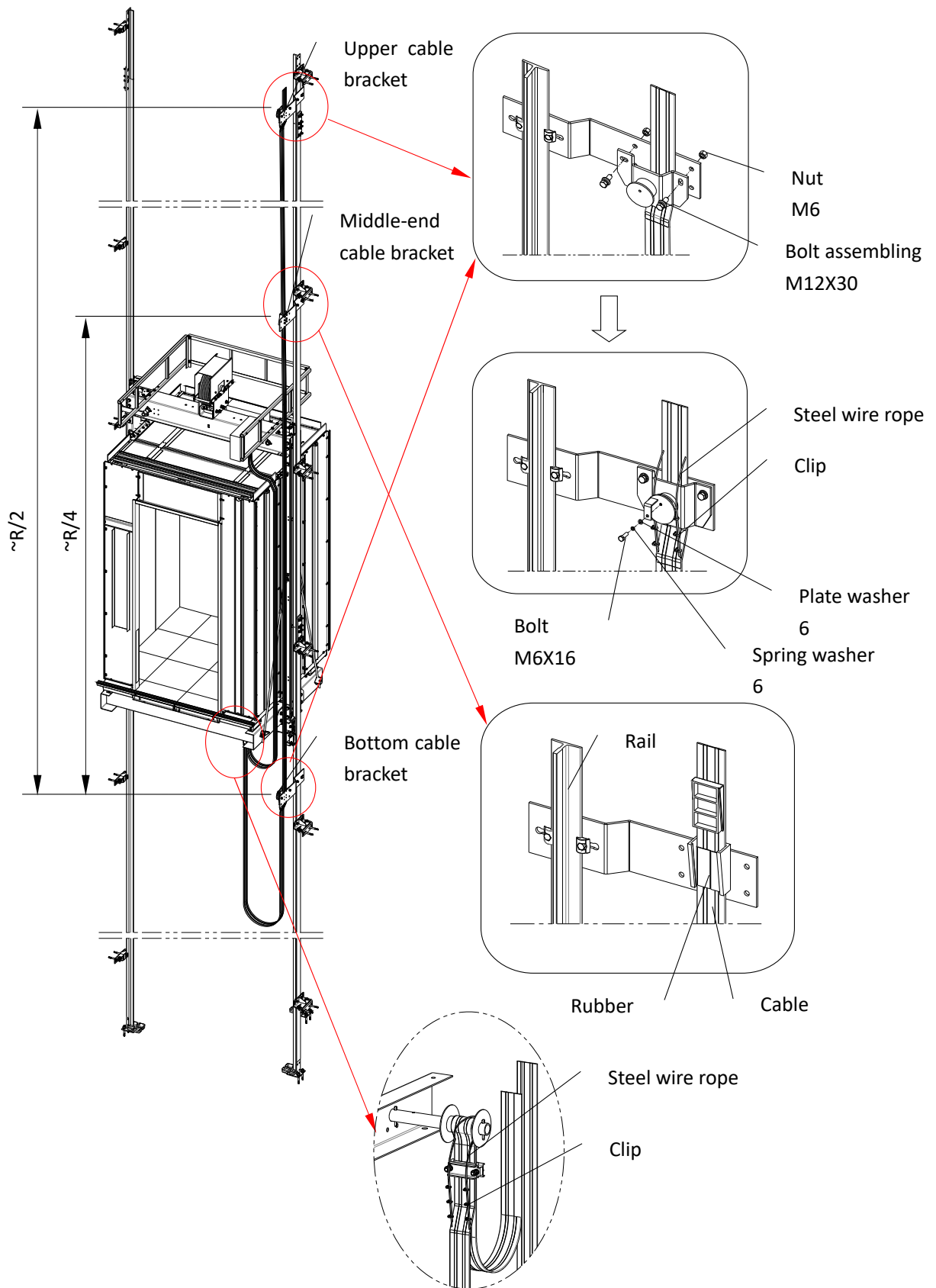

Figure 16-2 ( R>60m )

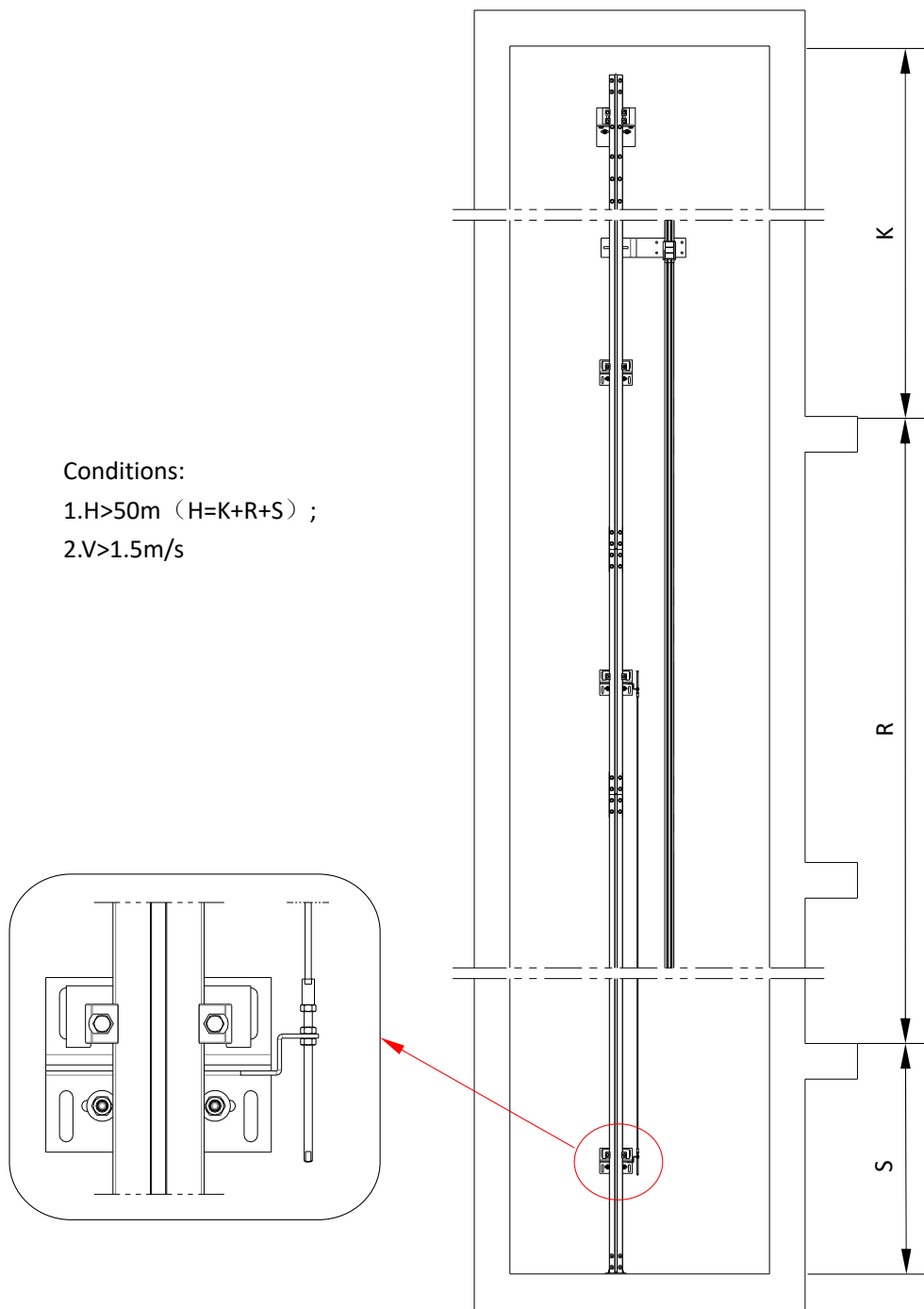

Figure 16-3

## 16.2 Installation of hoistway wiring

Step	Instruction	Fig
1	Fix the hoistway wire on the wall.	Figure 16-4

1. Hall fixtures, door locks and other branches of cable should be fixed at both ends and corner.

2. The distance between hoist-way wires and car parts should be more than 20mm.

3. The ground wire of door lock must be connected to the main ground wire in hoist-way.

4. The hoist-way wire should be fixed well, cables should be roughly perpendicular. All the grounding system must be in connection.

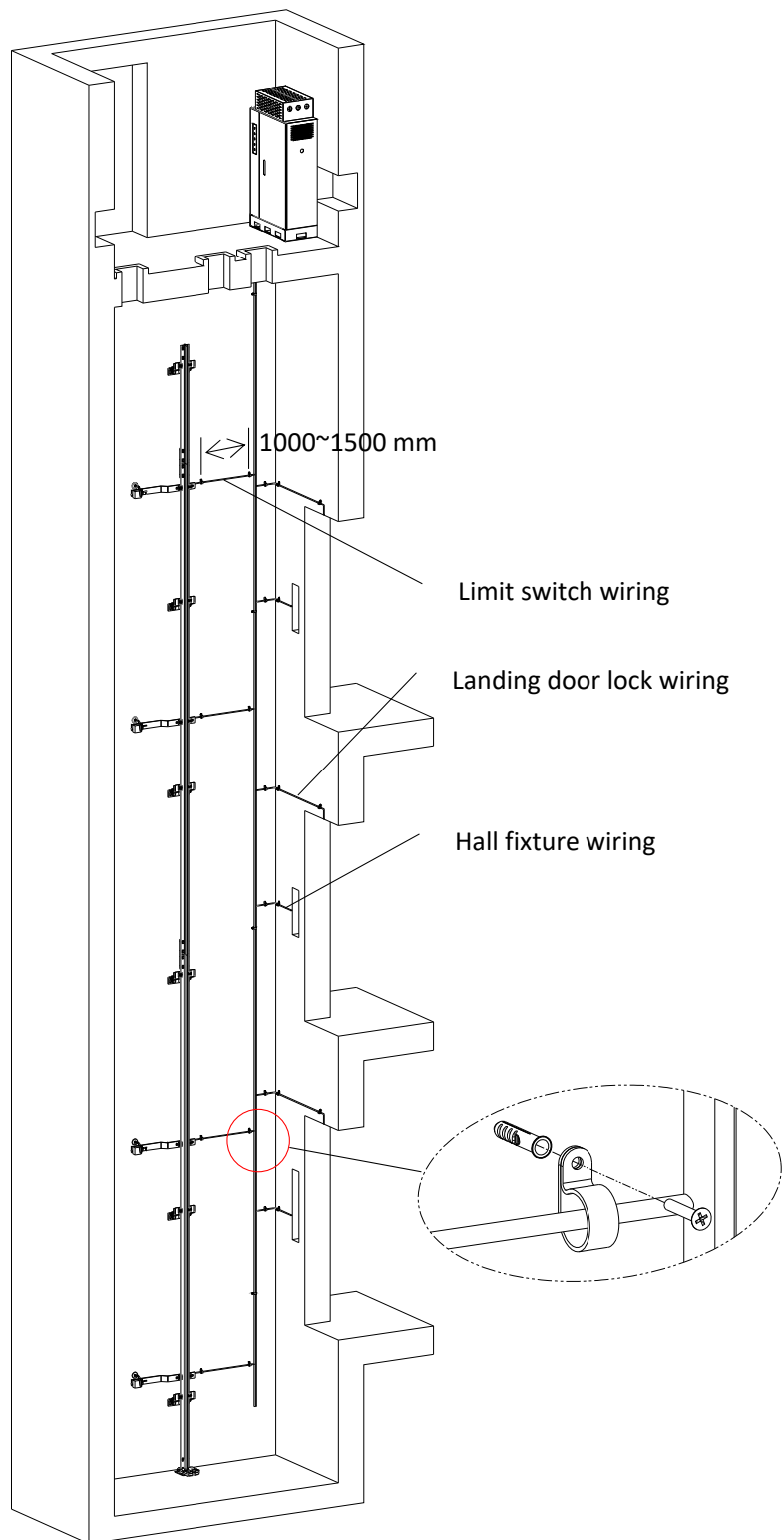

Figure 16-4

### 16.3 Installation of hoistway light

Step	Instruction	Fig
1	Fix the lamp on wall and connect wiring.	Figure 16-5

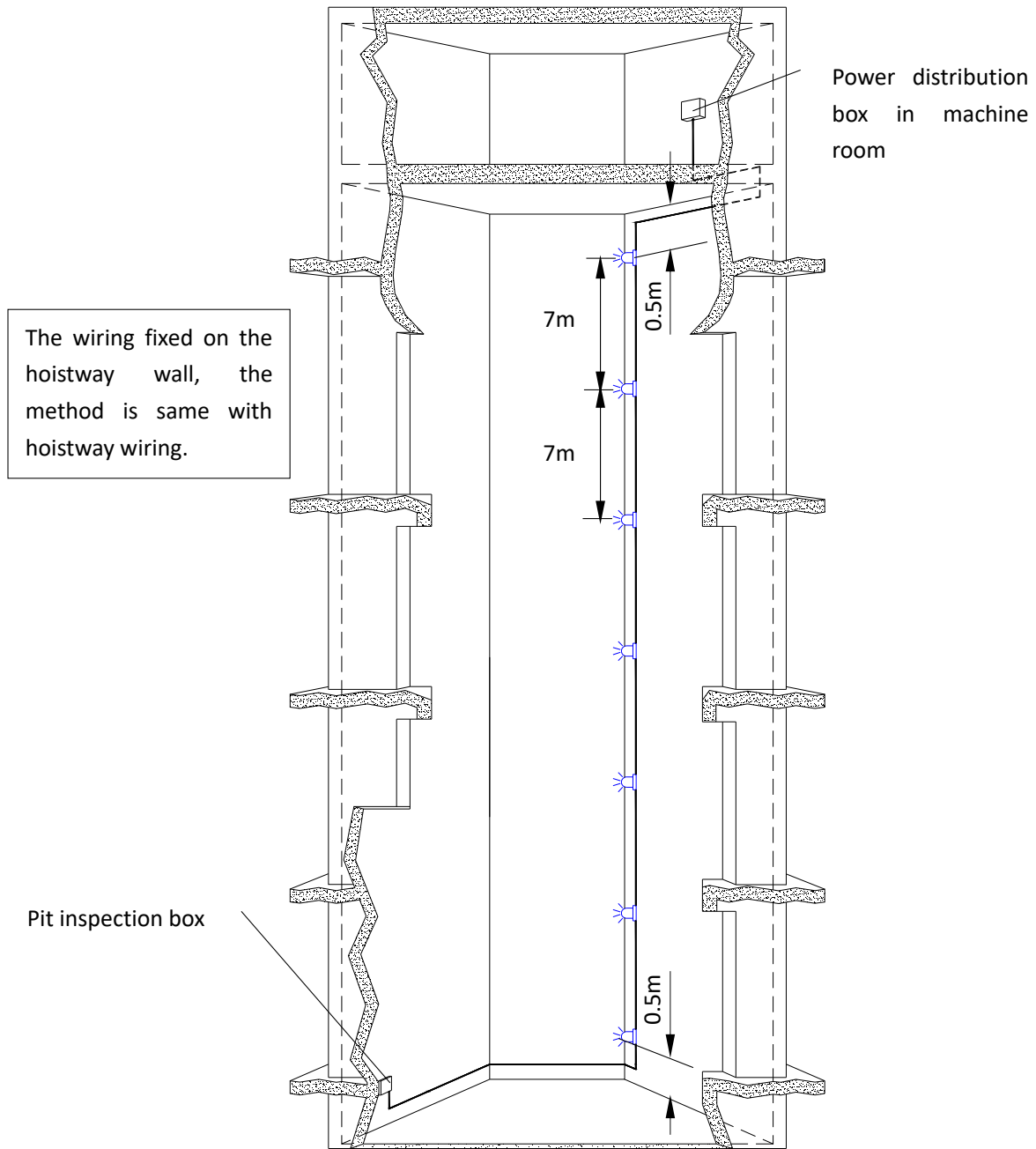
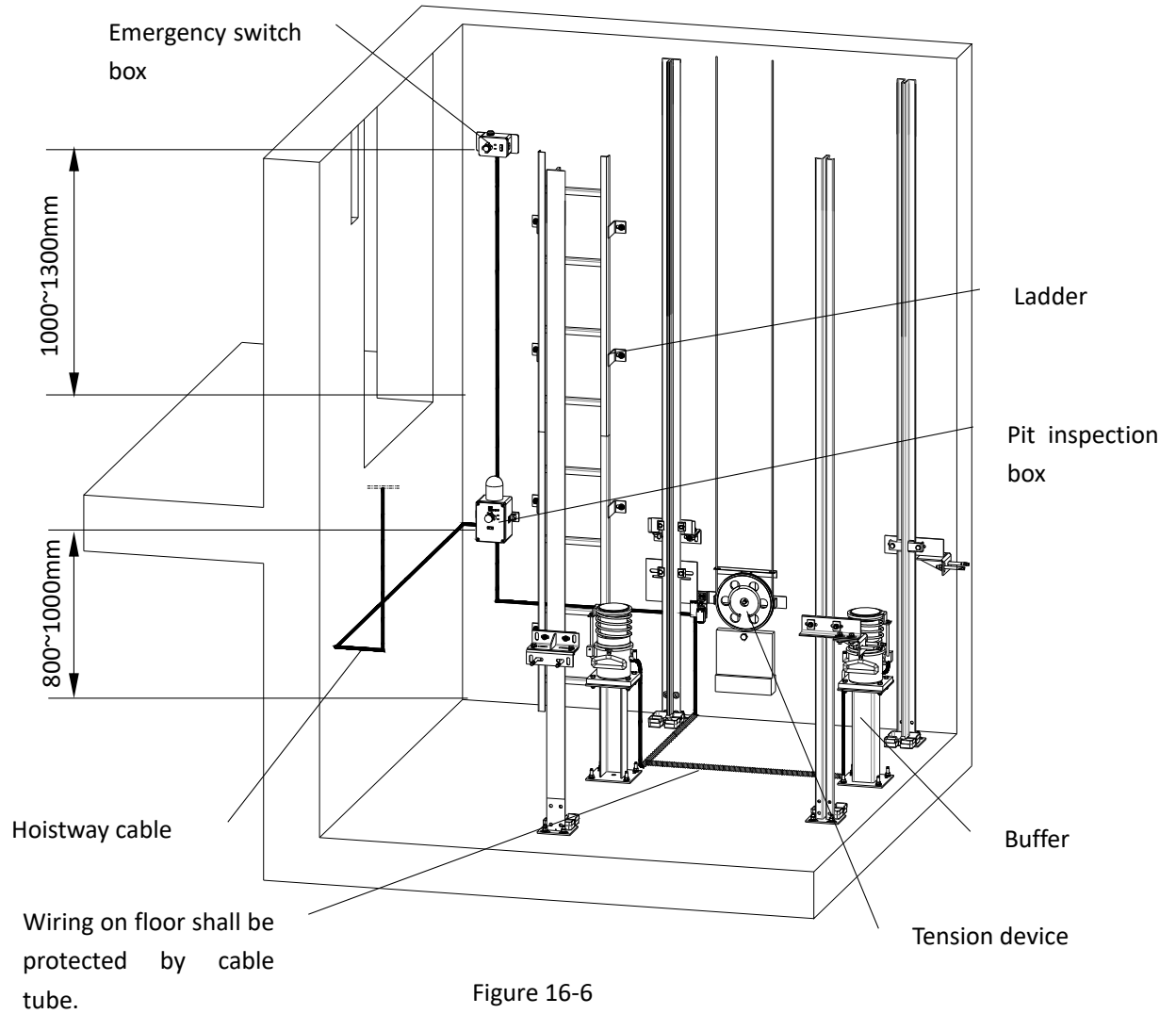

Figure 16-5

### 16.4 Installation of pit wiring

Step	Instruction	Fig
1	The drawing for pit wiring.	Figure 16-6





### 16.5 Installation of car wiring

Step	Instruction	Fig
1	Connect car device wiring to junction box. Fix the wiring on the car by nylon ribbon.	Figure 16-7

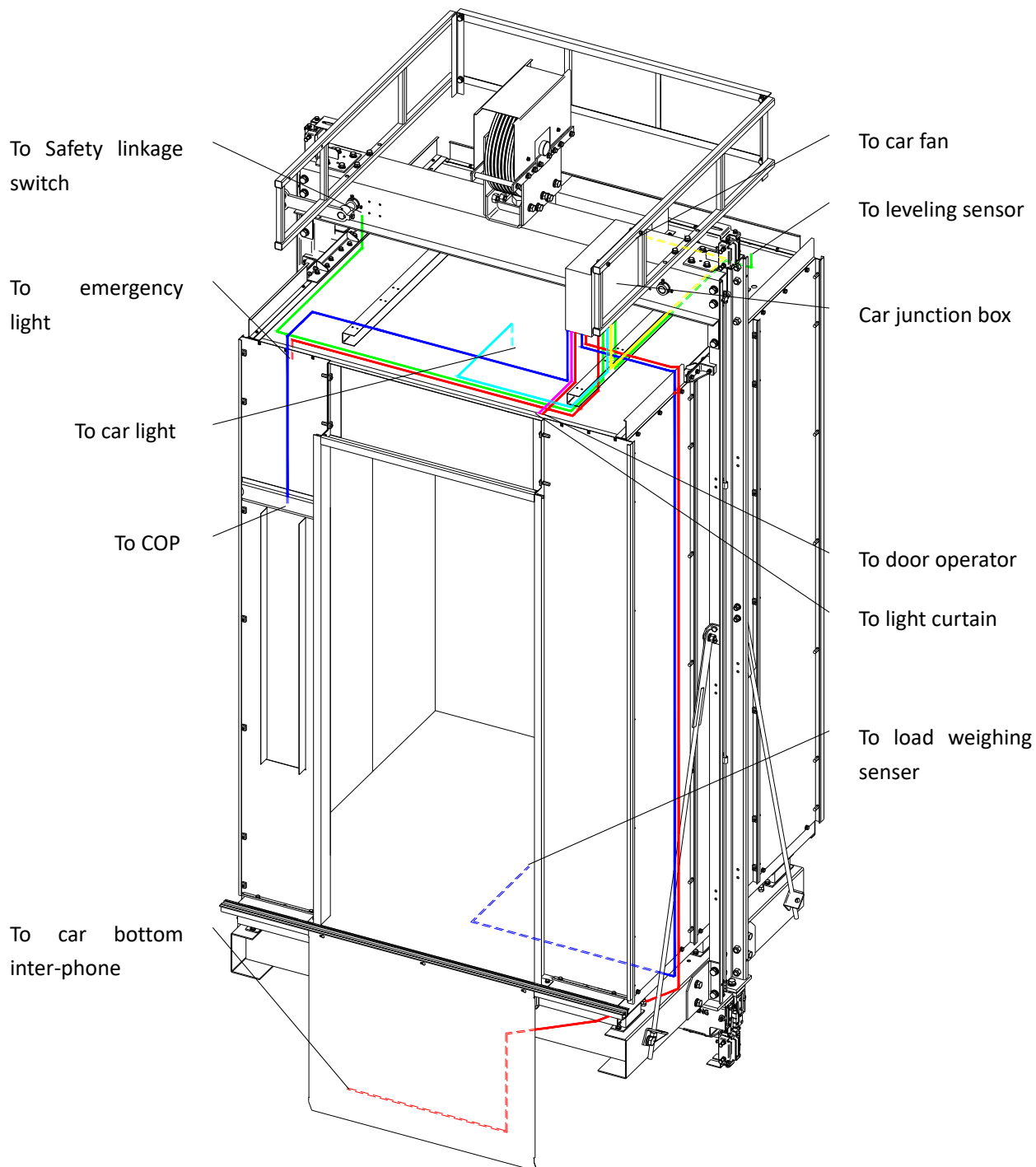

Figure 16-7

### 16.6 Installation of inter-communication device

Step	Instruction	Fig
1	The drawing for inter-communication device.	Figure 16-8
2	Connect interphone car bottom unit on toe guard.	Figure 16-9

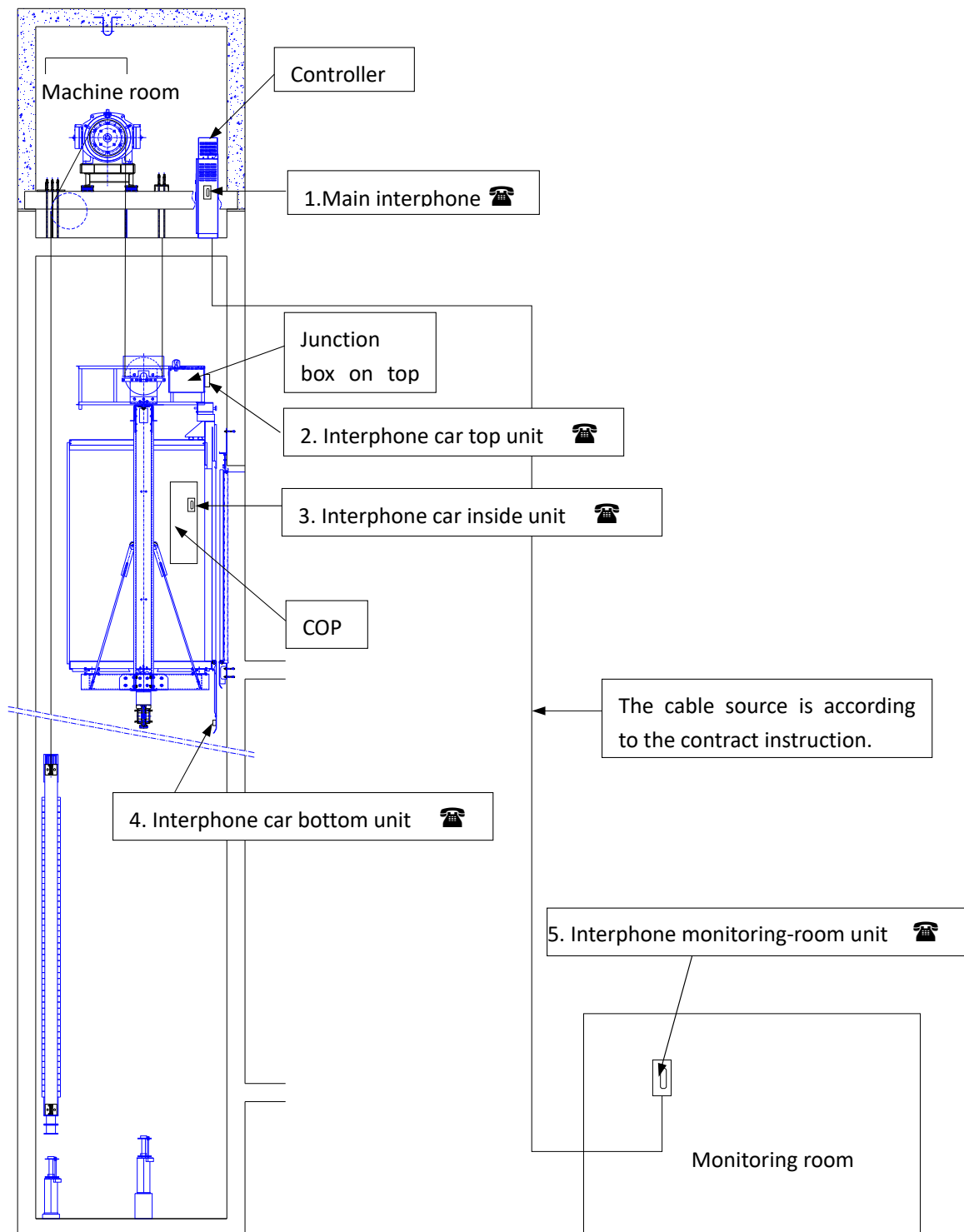

Figure 16-8

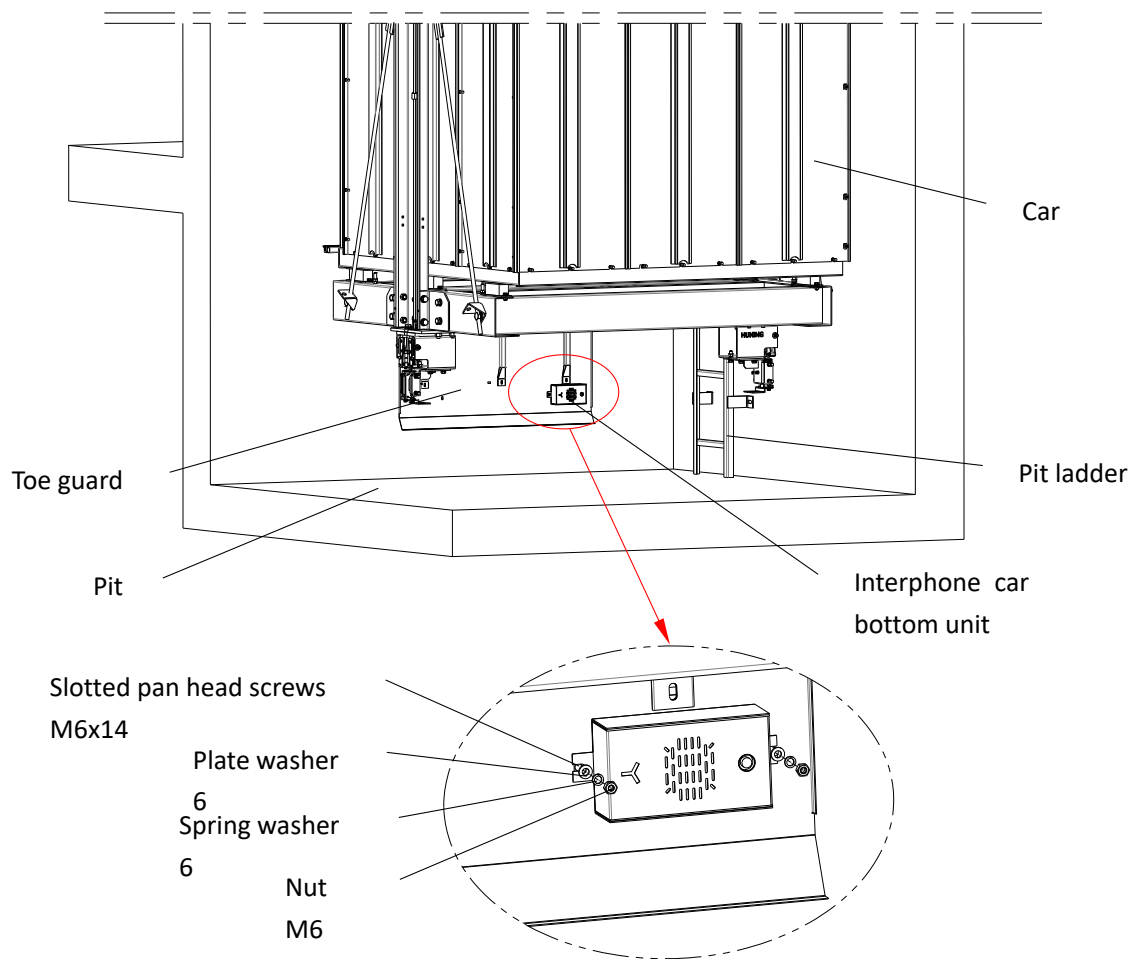

Figure 16-9

***The interphone car bottom unit should be installed at the ladder side on the car toe guard.***

## 17 Installation of human interface device

### 17.1 Installation of car operation panel

Step	Instruction	Fig
1	Connect the car operation panel on the car panel.	Figure 17-1

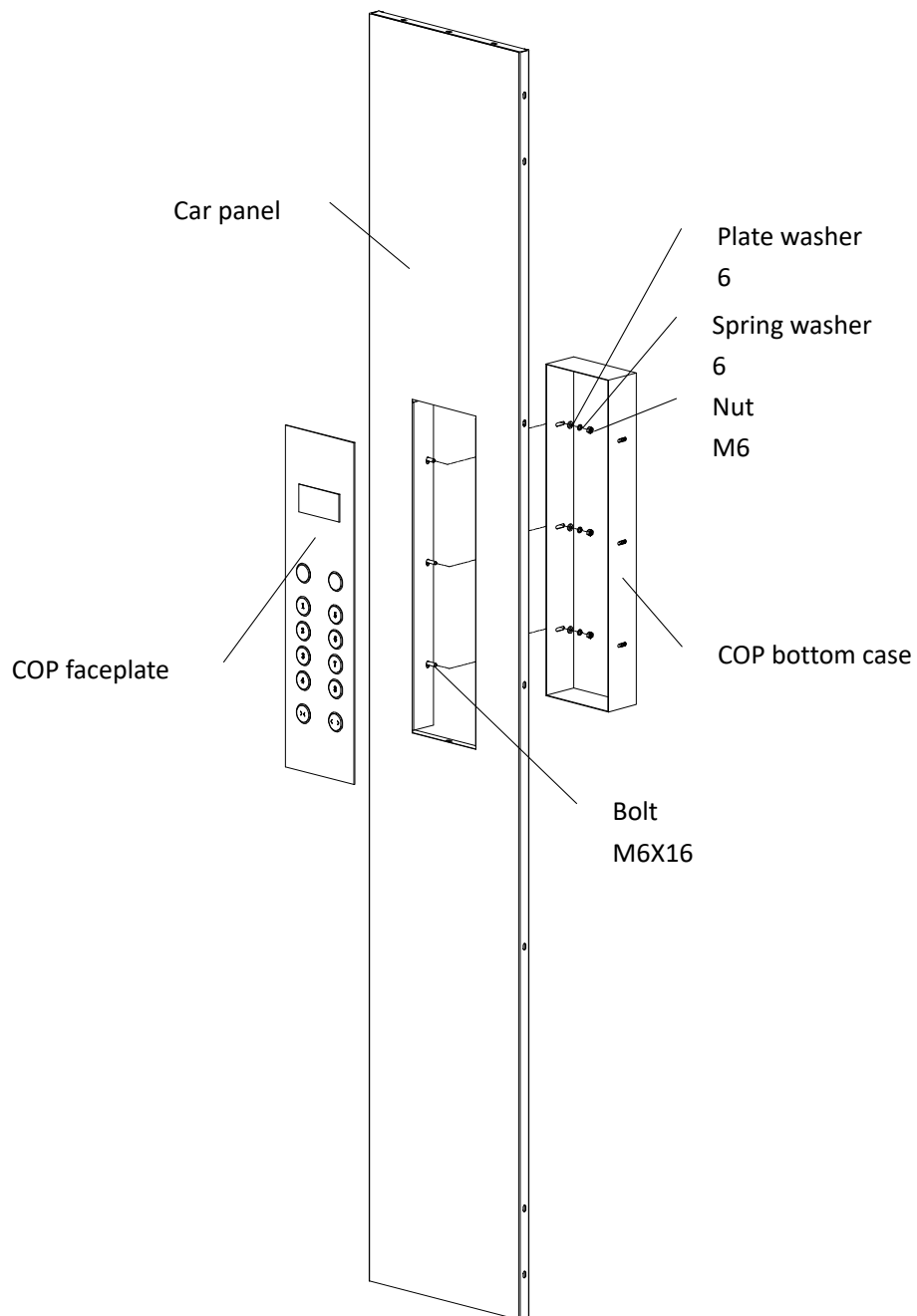

Figure 17-1

---

**17.2 Installation of hall fixture**

Step	Instruction	Fig
1	Connect the hall fixture on the well wall by cement.	Figure 17-2

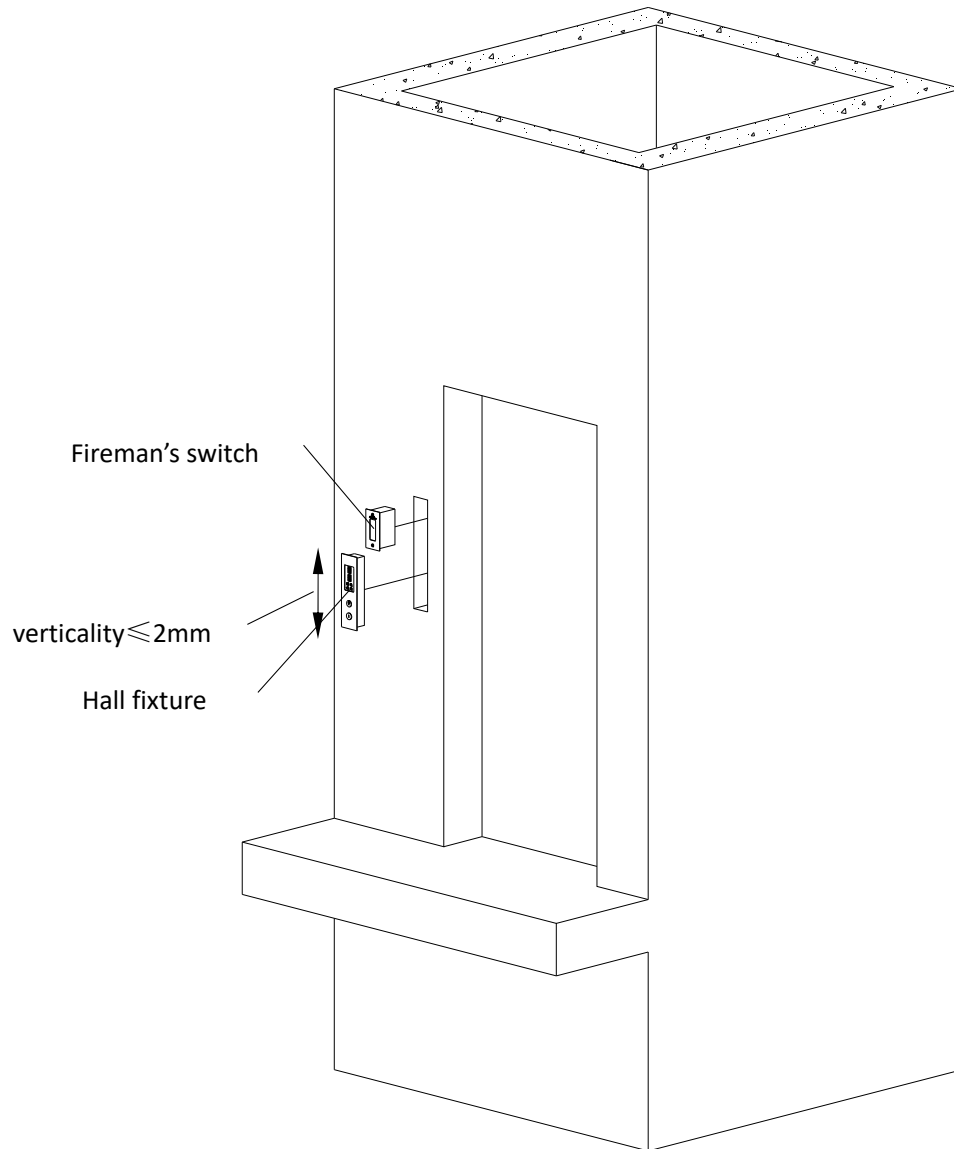

Figure 17-2

## 18 Installation finishing work

### 18.1 Clean up

Clean the pit, well, machine room and car roof etc;

Use a soft clean cloth and non-abrasive cleaner to clean the landing door, door jambs, HCPs and car doors;

Use a brush or vacuum cleaner to clean the sill and the car floor;

Use a soft clean cloth and non-abrasive cleaner to clean the wall of the car, the car roof, lintels, etc.

## 19 Annex

### 19.1 Fastener tightening torque requirements



Our company is using bolt strength of 8.8, using a torque wrench to tighten the bolts, the installation manual is not specifically identify the specific installation torque data ,refer to the following table to choose the right moment be tightening operation.

Table 6.2-1 bolt tightening torque

Bolt size	bolts	Tightening torque (N·m)			
		4.8	6.8	8.8	10.9
M6		4-5	6-8	9-12	13-14
M8		10-12	14-18	22-29	29-35
M10		20-25	29-39	44-58	64-76
M12		35-44	49-64	76-102	108-127
M16		88-108	127-157	189-252	274-323
M20		167-206	245-314	369-492	529-637
M24		294-370	441-539	638-850	921-1098
M30		529-666	784-980	1267-1689	1566-1960

### 19.2 Expansion bolt installation

#### 19.2.1 Common types of expansion bolt

figure	type	specification
	Expansion tube	M8X80 M10X100 M12X120 M16X140
	Expandable annular	M8X80 M10X100 M12X120 M16X140

### 19.2.2 Installation requirement

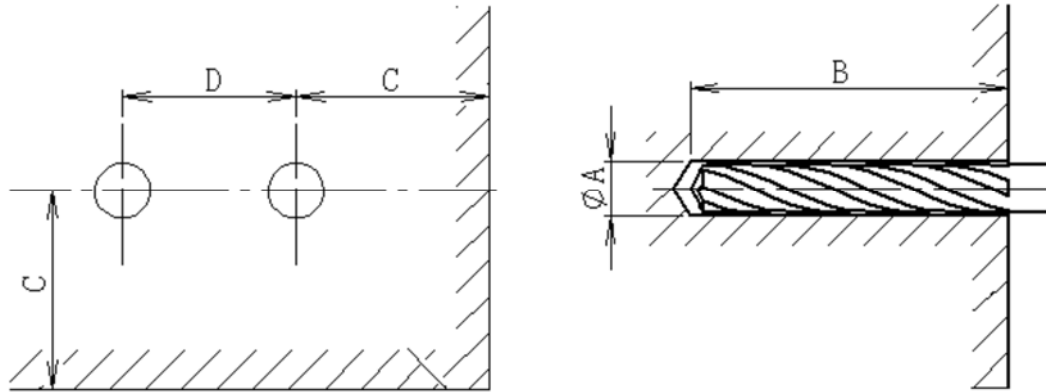

Expansion bolts Specifications		Drilling diameter A (mm)	Drilling depth B (mm)	Margins hole C (mm)	Margins hole D (mm)	Tightening torque (N·m)
Expansion tube	M8X80	12	60	≥70	≥60	13
	M10X100	14	65	≥75	≥65	26
	M12X120	18	85	≥100	≥85	50
	M16X140	22	95	≥125	≥105	110
Expandable annular	M8X80	8	65	≥65	≥55	13
	M10X100	10	80	≥70	≥60	26
	M12X120	12	90	≥95	≥80	50
	M16X140	16	110	≥120	≥100	110

### 19.2.3 Installation method

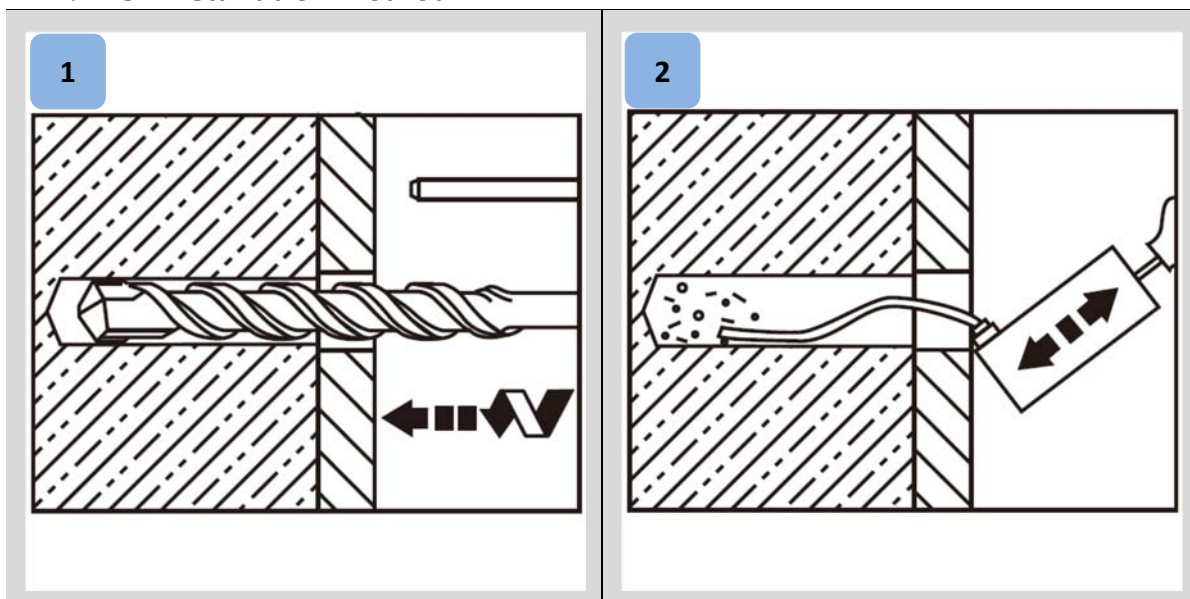

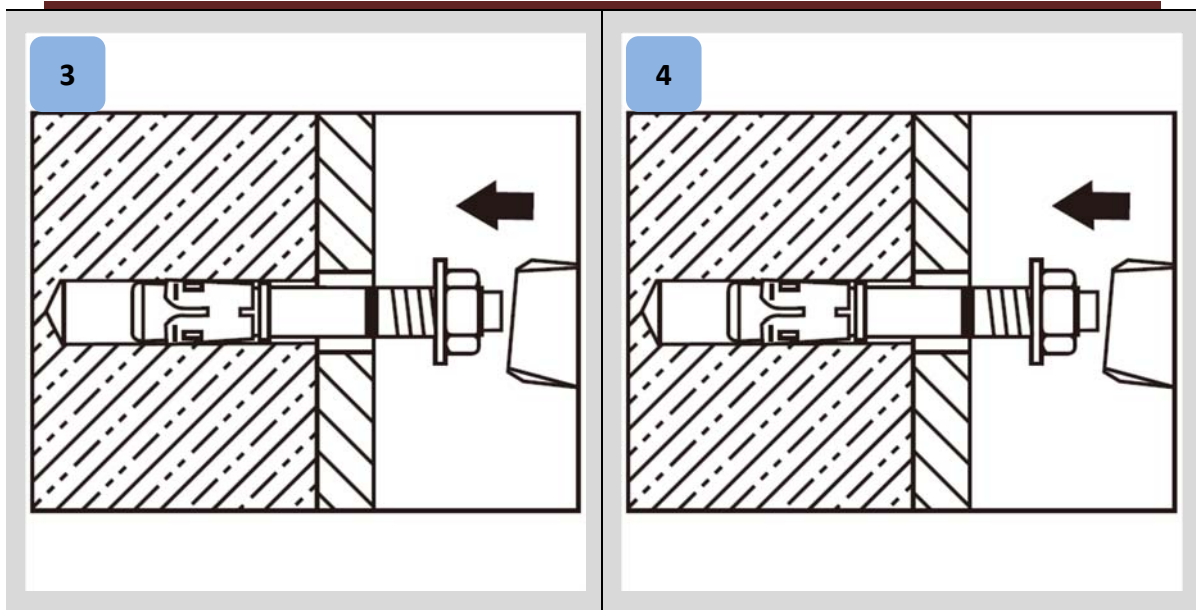

- 1) Drill holes at the marked point vertically to the wall;
- 2) Using the system tools to clean dust and debris from the hole;
- 3) Put the expansion bolt vertically into the hole;
- 4) Use a torque wrench to the specified torque fastening bolts.